

## ***advanced FLOW engineering***

Turbo Inlet (for Takeda Intake)

### **Instruction Manual** P/N: 55-20004

---

<b>Make:</b> HYUNDAI	<b>Model:</b> SONATA N-LINE	<b>Year:</b> 2021-2026	<b>Engine:</b> L4-2.5L (t)
(Only fits with Takeda Intake: 56-10073D, 56-10073R)			
<b>Make:</b> KIA	<b>Model:</b> K5 GT	<b>Year:</b> 2021-2026	<b>Engine:</b> L4-2.5L (t)
(Only fits with Takeda Intake: 56-70073D, 56-70073R, 56-10073D, 56-10073R)			



- Please read the entire instruction manual before proceeding.
- Ensure all components listed are present.
- If you are missing any of the components, call customer support at 951-493-7185.
- Ensure you have all necessary tools before proceeding.
- Do not attempt to work on your vehicle when the engine is hot.
- Retain factory parts for future use.

Label	Qty.	Description	Part Number
A	1	Clamp, 048 (2-9/16" - 3-1/2 ")	03-50007
B	1	Clamp, 044 (2-5/16" - 3-1/4")	03-50019
C	1	Adaptor, Turbo Inlet	05-01833
D	1	Tube, Silicone: 2-5/8" x 3" x 56 Deg	05-5520004B1

**Installation will require the following tools:**

Socket Set, Extensions, Ratchet wrench, Pliers, Screw Driver Set, Allen Key Set

Warranty Information available at: <https://afepower.com/warranty>

**Emissions Disclaimer:** This product is not currently CARB exempt and is not available for purchase in California or for use on any vehicle registered with the California Department of Motor Vehicles. CARB exemption applications can take time to process, please contact us or visit our website for the latest updates on its status.

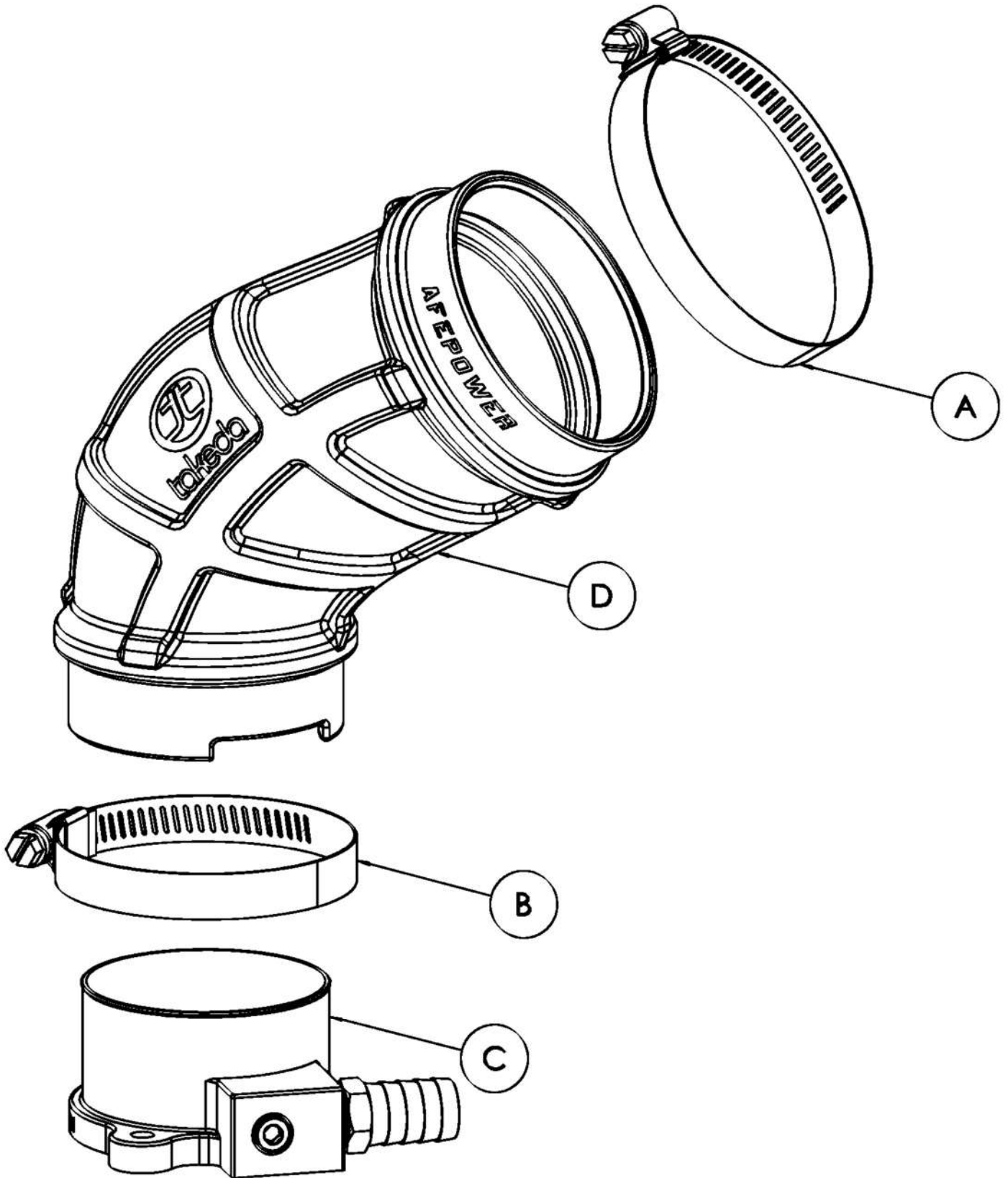

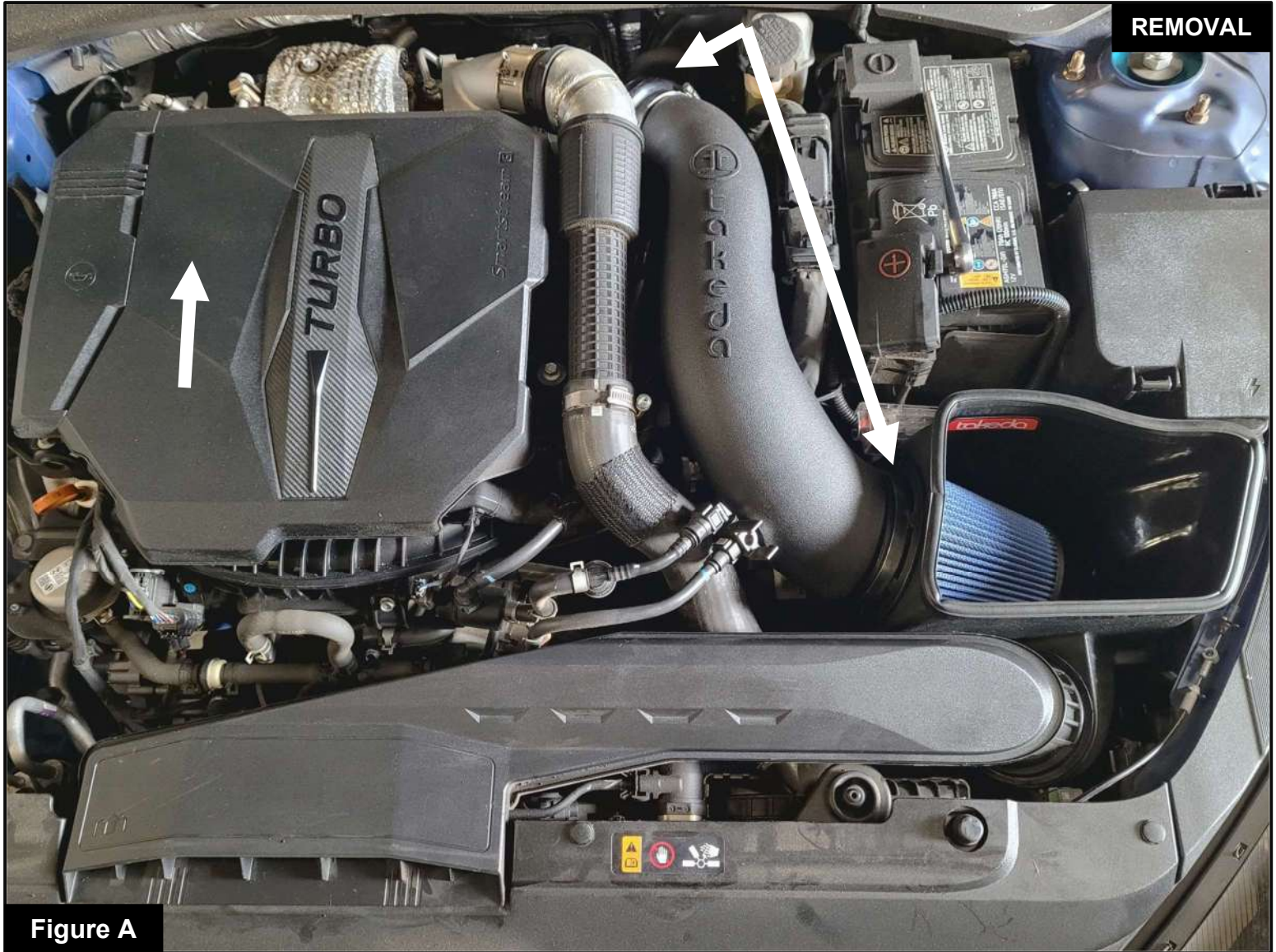

Figure A

**Refer to Figure A for Steps 1-2**

**ONLY COMPATIBLE WITH TAKEDA INTAKE SYSTEMS:**

56-70073D, 56-70073R, 56-10073D, 56-10073R.

Step 1: Remove the engine cover by pulling straight up.

Step 2: Use an 8mm driver or socket wrench to loosen the clamp on the air filter and both clamp on the silicone coupler.

**Figure B**

### **Refer to Figure B for Steps 3-5**

Step 3: Disconnect both ejector fitting quick-connect hoses by pressing the side release tabs and pulling the fittings straight off.

Step 4: Disconnect the recirculation quick-disconnect hose located at the bottom of the **TAKEDA** intake tube by pressing the release tabs on both sides and pulling the hose straight out; you may need to reach around the intake tube with both hands for better access.

Step 5: Remove the **TAKEDA** intake tube and the silicone coupler.



**Refer to Figure C for Steps 6-7**

**DISCLAIMER:** Take extra care when removing the factory turbo inlet. An O-ring sits between the turbo and the turbo inlet and can easily fall out. Make sure it does not fall, or be prepared to catch it if it does.

Step 6: Use pliers to open the factory spring clamp securing the hose to the turbo inlet. Slide the clamp back from the tube and disconnect the rubber hose from the turbo inlet.

Step 7: Use a 10 mm socket with an extension and ratchet wrench to loosen the screws securing the factory turbo inlet to the turbo. Carefully remove the screws and remove the turbo inlet, making sure the O-ring does not fall from the face groove on the turbo. Screws will be used later during installation.

**Figure D****Refer to Figure D for Step 8**

Step 8: Take this time to inspect the O-ring for any defects. It is recommended to clean the O-ring and the face groove, then apply a small amount of grease to the O-ring to help hold it in place for the following steps.

**Figure E****Refer to Figure E for Steps 9-10**

**DISCLAIMER:** Fittings come pre-installed but may require final tightening before installation.

Step 9: Use an 11/16" wrench to tighten the pre-installed 3/8" NPT barbed fitting on the **TAKEDA** turbo Inlet adaptor. Do not overtighten, as this can damage the threads. If some threads remain exposed, that is okay.

Step 10: Use a 3/16" Allen key to tighten the pre-installed 1/8" NPT plug on the **TAKEDA** turbo Inlet adaptor. Do not overtighten, as this can damage the threads. If some threads remain exposed, that is okay.

**Figure F****Refer to Figure F for Steps 11-13**

Step 11: Carefully position the **TAKEDA** turbo inlet adaptor onto the turbo inlet face, making sure the O-ring is still in the turbo face groove and is not pinched.

Step 12: Use a 10 mm socket with an extension and ratchet wrench to tighten the factory screws removed in **Step 7**, securing the **TAKEDA** turbo inlet adaptor to the turbo.

Step 13: Connect the rubber hose to the barbed fitting. Use pliers to open the factory spring clamp and slide it into position to secure the hose.

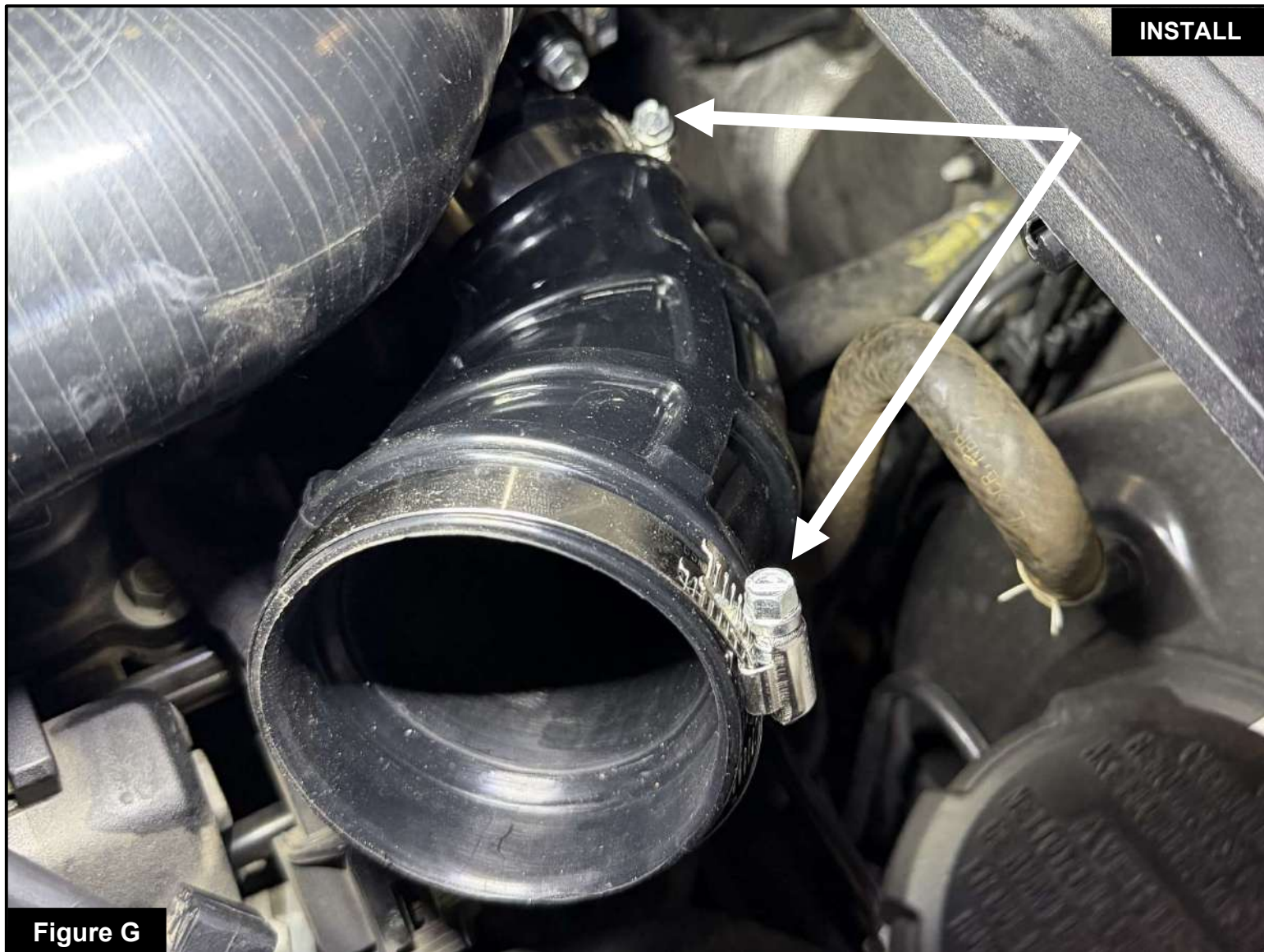

**Figure G**

**Refer to Figure G for Steps 14-15**

Step 14: Install Clamp #44 onto the notched end of the **TAKEDA** turbo inlet tube, then install the tube onto the **TAKEDA** turbo inlet adaptor. Make sure to align the notch in the tube with the adaptor to ensure correct orientation. Use an 8 mm driver or socket wrench to tighten the clamp securing the tube to the adaptor.

Step 15: Loosely install Clamp #48 onto the **TAKEDA** turbo inlet tube. Do not tighten it at this time.

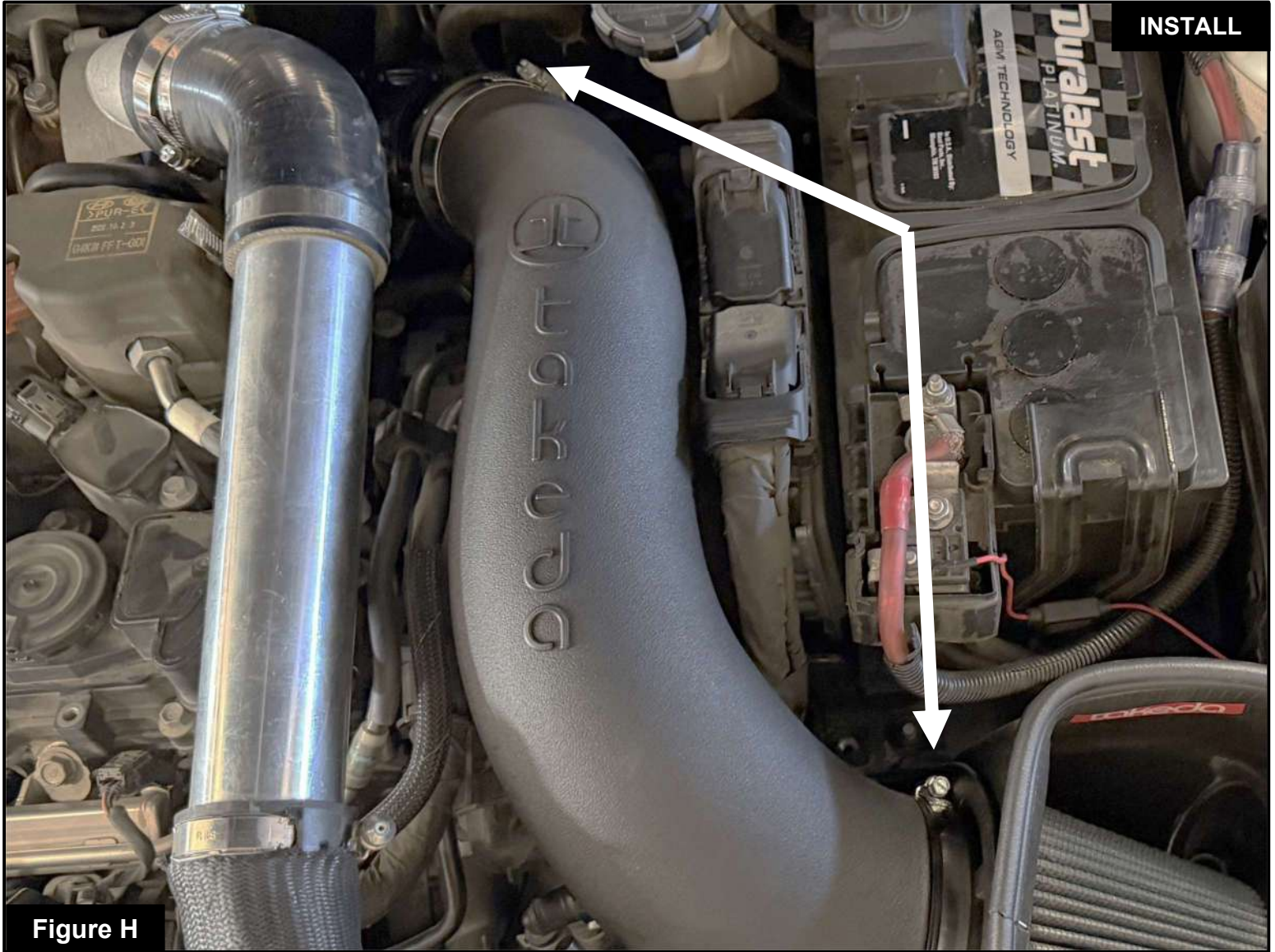
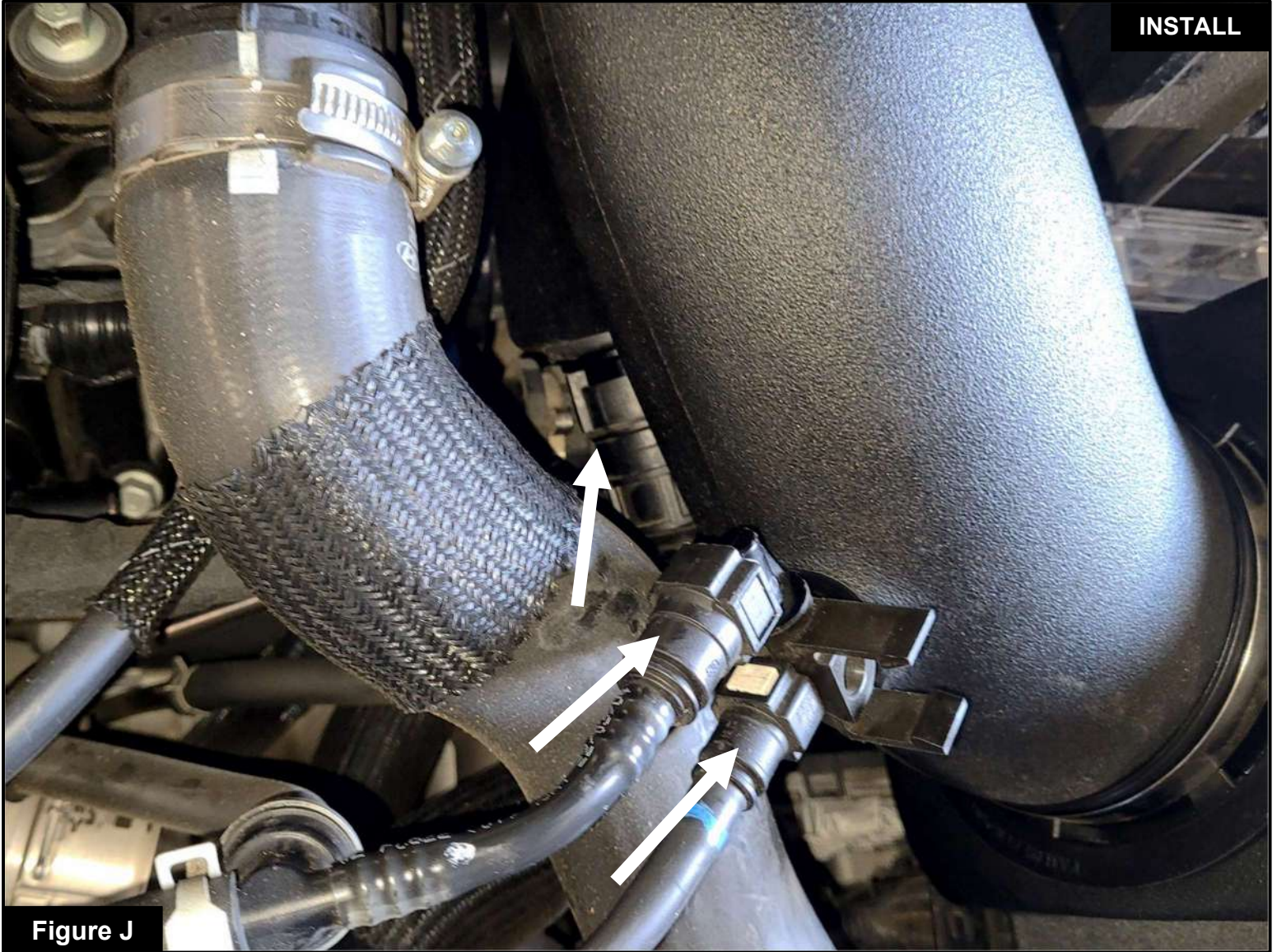

Figure H

**Refer to Figure H for Steps 16-17**

Step 16: Install the **TAKEDA** intake tube by sliding it into the air filter first, then into the **TAKEDA** turbo inlet tube.

Step 17: Use an 8mm driver or socket wrench to tighten the clamp on the air filter and the clamp on the **TAKEDA** turbo inlet tube.

**Figure J****Refer to Figure J for Steps 18-19**

Step 18: Reconnect the recirculation quick-disconnect hose by pushing it straight onto the fitting at the bottom of the **TAKEDA** intake tube until the release tabs click securely into place.

Step 19: Reconnect both quick-connect hoses to the ejector fitting until the side tabs click securely into place.

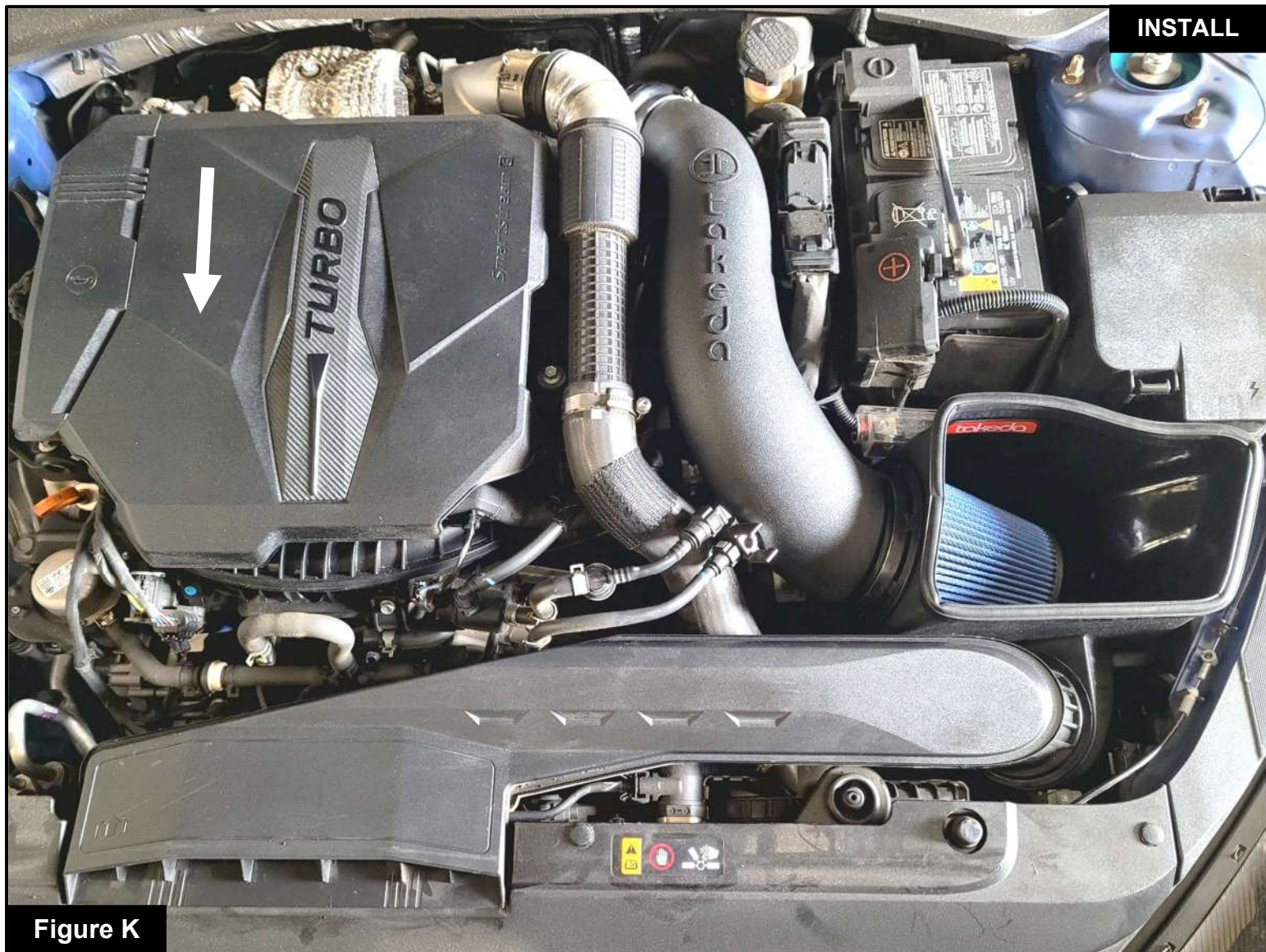
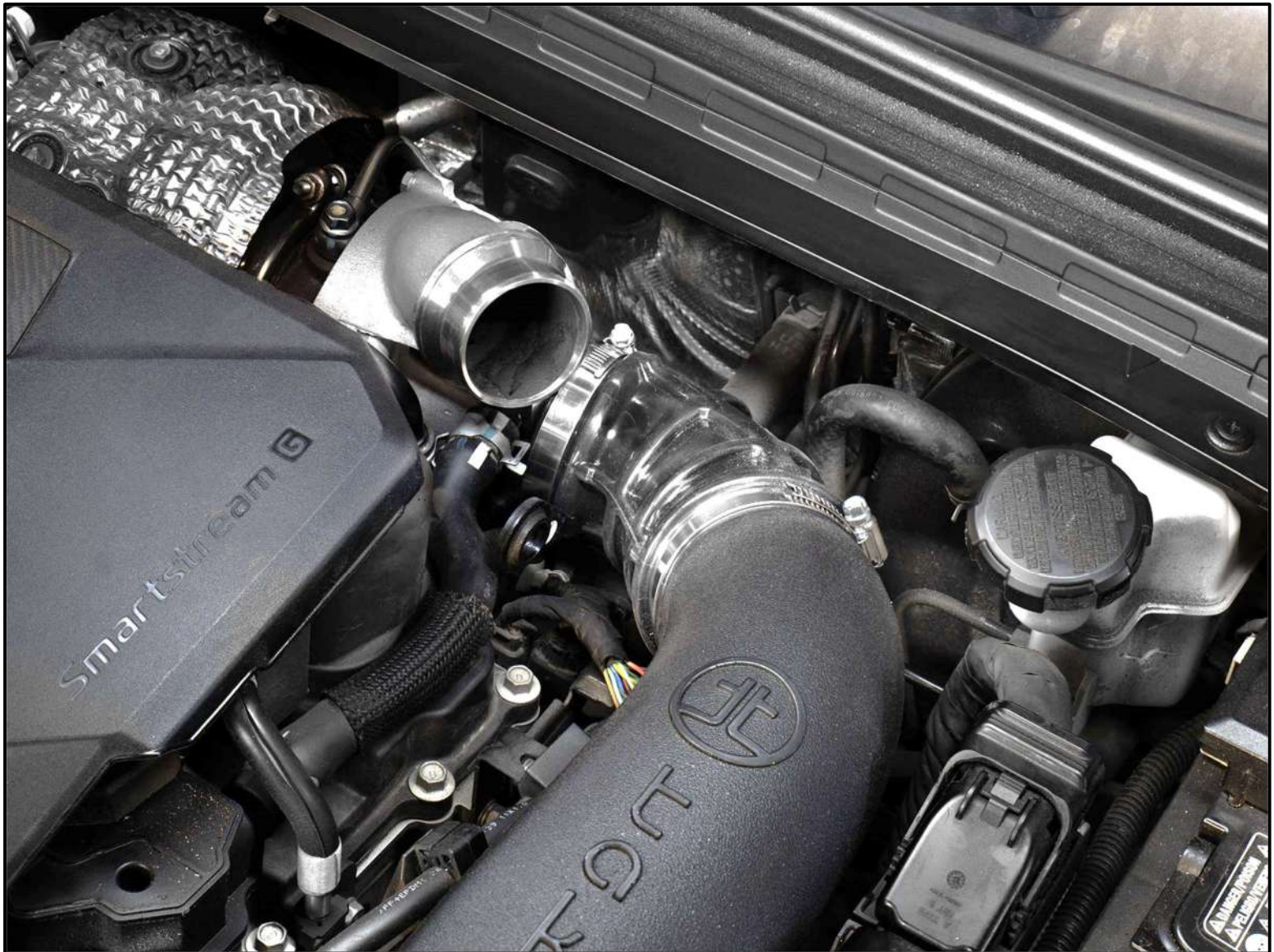

Figure K

**Refer to Figure K for Step 20**

Step 20: Install the engine cover by lining up the pegs with the grommets and firmly pressing down.



**(CHARGE PIPE REMOVED FOR PHOTO CLARITY.)**

**Your installation is now complete. Thank you for choosing TAKEDA USA!**

**NOTE: Check to ensure that all screws, clamps, and connectors are secure after 100-200 miles.**



PAGE LEFT BLANK INTENTIONALLY



***advanced FLOW engineering, inc.***

Corona, CA 92879

<https://afepower.com/contact-us>