

## 23+ / FORD SUPER DUTY

### ADAPTIVE CRUISE CONTROL BRACKET

AC81152501NA



### TOOLS REQUIRED

(Socket) 10mm, 15mm, 18mm, 5/32, 5/16, 7/16, 9/16  
(Wrench) 10mm, 15mm, 18mm, 5/32, 5/16, 7/16, 9/16  
(Allen) 5/32, 7/32  
(Drill Bit) 13/32  
Fastener Removal Tool/Flathead



### TIME REQUIRED

- 1 hours for OEM Removal/ACC Install



### SKILL LEVEL

-Easy/Intermediate



### INCLUDED IN KIT

- 3- 3/8-16 X 1" Button Head Bolt
- 3- 3/8" Flat Washer
- 3- 3/8-16" Nylon Lock Nut
- 4- 1/4-20 X 3/4" Button Head Bolt
- 5- 1/4" Flat Washer
- 5- 1/4-20" Nylon Lock Nut
- 1- 1/4-20 X 3/4" Carriage Bolt

## **⚠ WARNINGS/CAUTIONS BEFORE STARTING INSTALLATION ⚠**

### **-BEFORE YOU INSTALL THIS KIT-**

Read and understand all instructions, warnings, cautions, & notes contained in this installation instruction guide. Consult your vehicle owner's manual for proper disconnection of electrical and lifting of vehicle if required for installation of this product.

This install may require some technical skills and knowledge of basic mechanical work. If you do not feel that you are capable of performing this install please take this product to a trained professional.

After reading this guide please contact us with any questions or concerns before installing product.  
Customer Service (480) 671-0820

Addictive desert designs is *not* responsible for any bodily injury or harm to you or your vehicle as a result of an improper install.

Proper installation of this kit required knowledge of the factory recommended procedures for removal and installation of original equipment components.

We recommend that the factory shop manual and any special tools needed to service your vehicle be on hand during the installation. Installation of this kit without proper knowledge of the factory recommended procedures may affect the performance of these components and the safety of the vehicle.

Inspect all contents of this package to make sure product is not damaged and all installation hardware has been included. If parts are missing from kit, please be prepared to provide the following information:

1. Name of purchase location
2. Bar Code on side of box
3. Date above bar code
4. Date inside box cover

**\*ALWAYS WEAR EYE PROTECTION  
WHEN OPERATING POWER TOOLS\***

## HARDWARE/PARTS

**A.**



3/8-16 X 1" BUTTON HEAD BOLT

QTY: 3

**A1.**



3/8" FLAT WASHER

QTY: 3

**A2.**

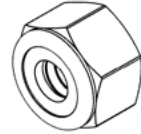

3/8-16" NYLON LOCK NUT

QTY: 3

**B.**



1/4-20 X 3/4" BUTTON HEAD BOLT

QTY: 4

**B1.**



1/4" FLAT WASHER

QTY: 5

**B2.**

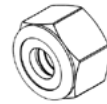

1/4-20" NYLON LOCK NUT

QTY: 5

**C.**



1/4-20 X 3/4" CARRIAGE BOLT

QTY: 1

**Reference this page throughout the install**

## ADAPTIVE CRUISE CONTROL BRACKET 23+ / FORD SUPER DUTY

## REMOVAL

### STEP 1

Unplug the wiring harness located behind the bumper on the driver side frame rail.



## ADAPTIVE CRUISE CONTROL BRACKET 23+/FORD SUPER DUTY

## REMOVAL

### STEP 2

Using a (fastener removal tool/flathead screwdriver) remove the clips holding the plastic molding.



## ADAPTIVE CRUISE CONTROL BRACKET 23+/FORD SUPER DUTY

## REMOVAL

### □ STEP 3

Pull the plastic off to expose the mounting bolt.



## ADAPTIVE CRUISE CONTROL BRACKET 23+ / FORD SUPER DUTY

## REMOVAL

### □ STEP 4

Locate the ACC module and remove the plug-in by pushing the tab down on the backside, next remove the bolts holding the ACC using a (5/32 socket). **\*\*set the ACC aside and reference the ACC guide when the bumper is removed\*\***



## ADAPTIVE CRUISE CONTROL BRACKET 23+ / FORD SUPER DUTY

## REMOVAL

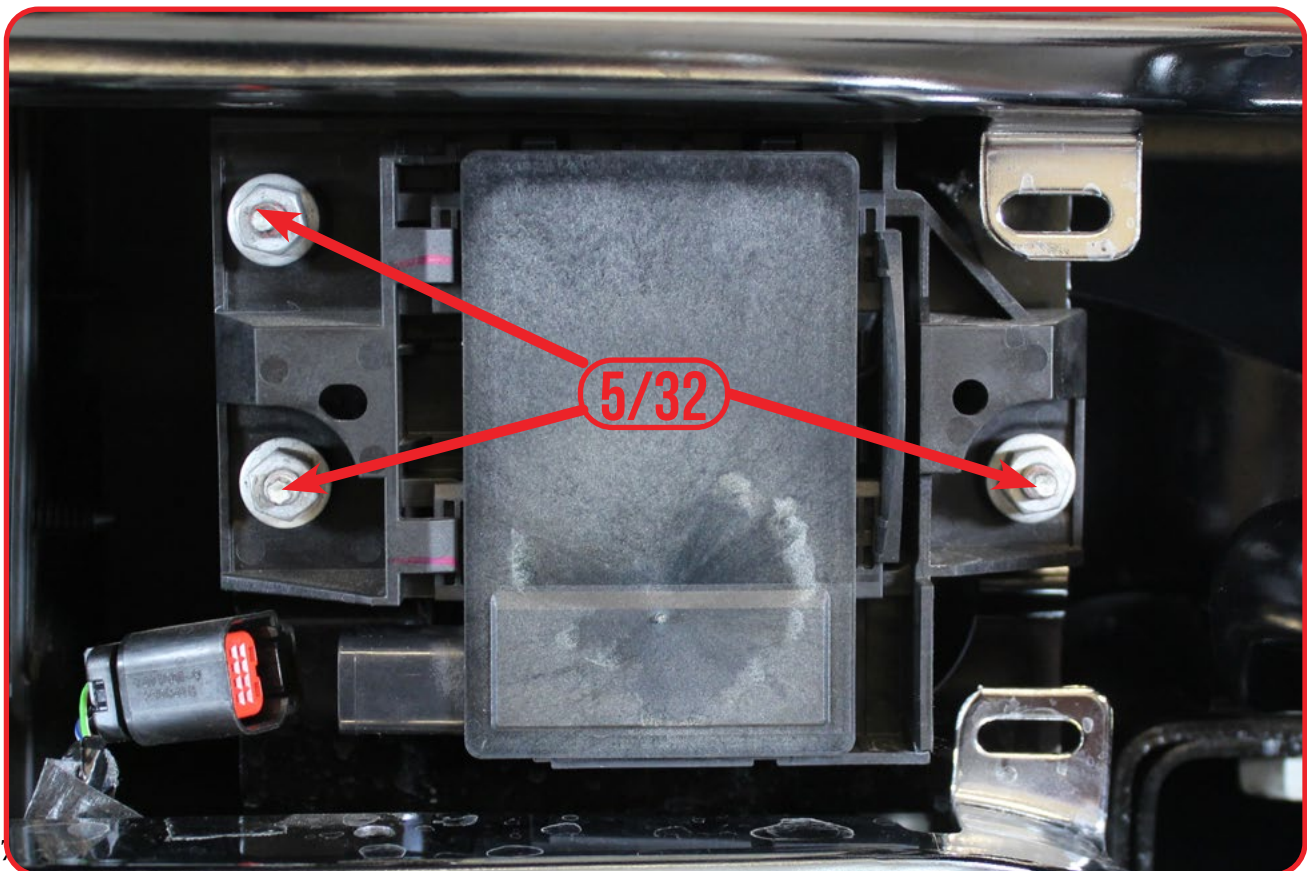
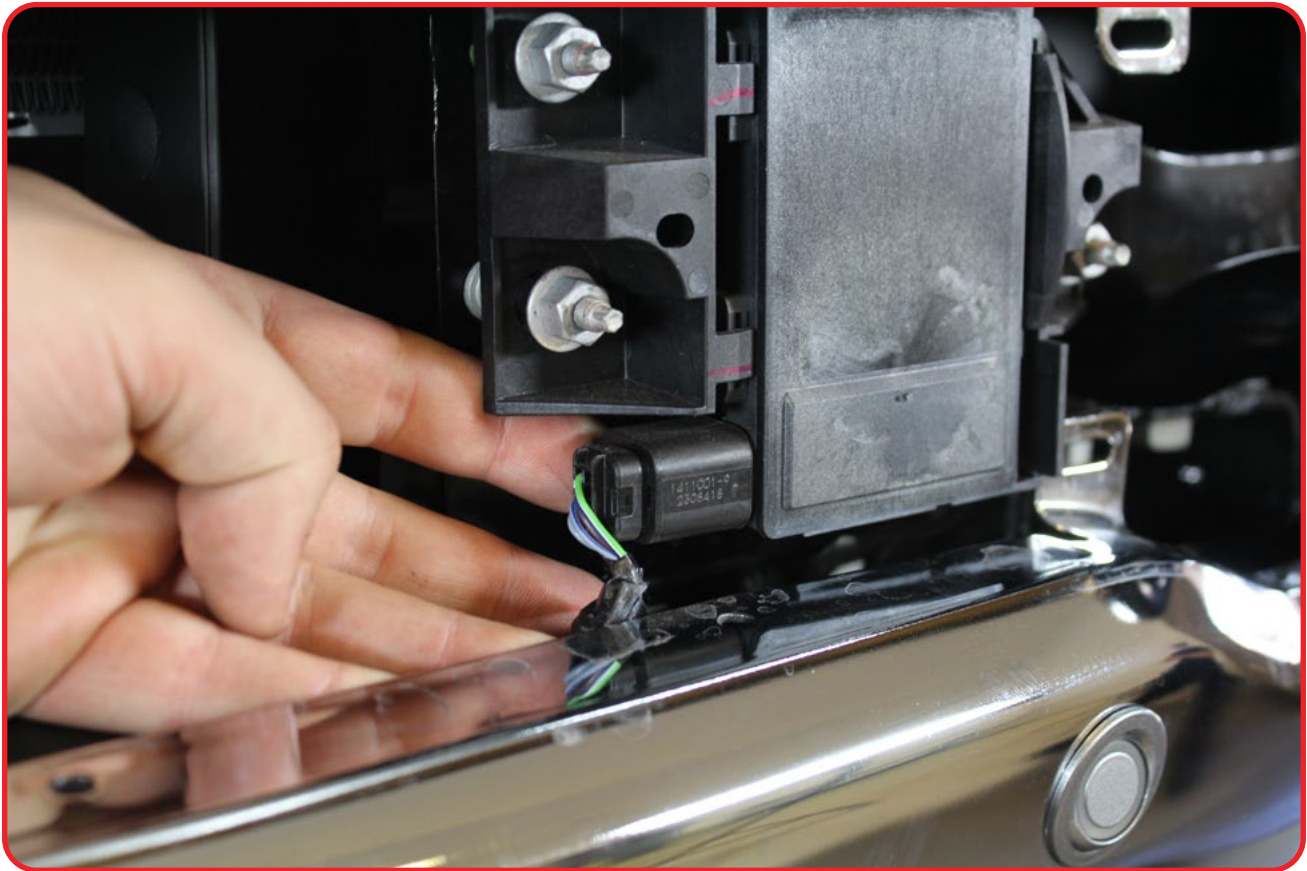

## ADAPTIVE CRUISE CONTROL BRACKET 23+ / FORD SUPER DUTY

## REMOVAL

### □ STEP 5

Remove the two bolts per side that are located behind the bumper along the frame rail using a (15mm Socket). (Save hardware and nut clips for they will be used later on in the install)



## ADAPTIVE CRUISE CONTROL BRACKET 23+ / FORD SUPER DUTY

## REMOVAL

### □ STEP 6

Remove the four mounting bolts on each side using a (18mm Socket) and remove the plastic push pin located between the bumper and grill using a (fastener removal tool). You can now remove the stock bumper.



## ADAPTIVE CRUISE CONTROL BRACKET 23+/FORD SUPER DUTY

## REMOVAL

### □ STEP 7

Remove the 4x bolts (each side) using a (5/16 socket).

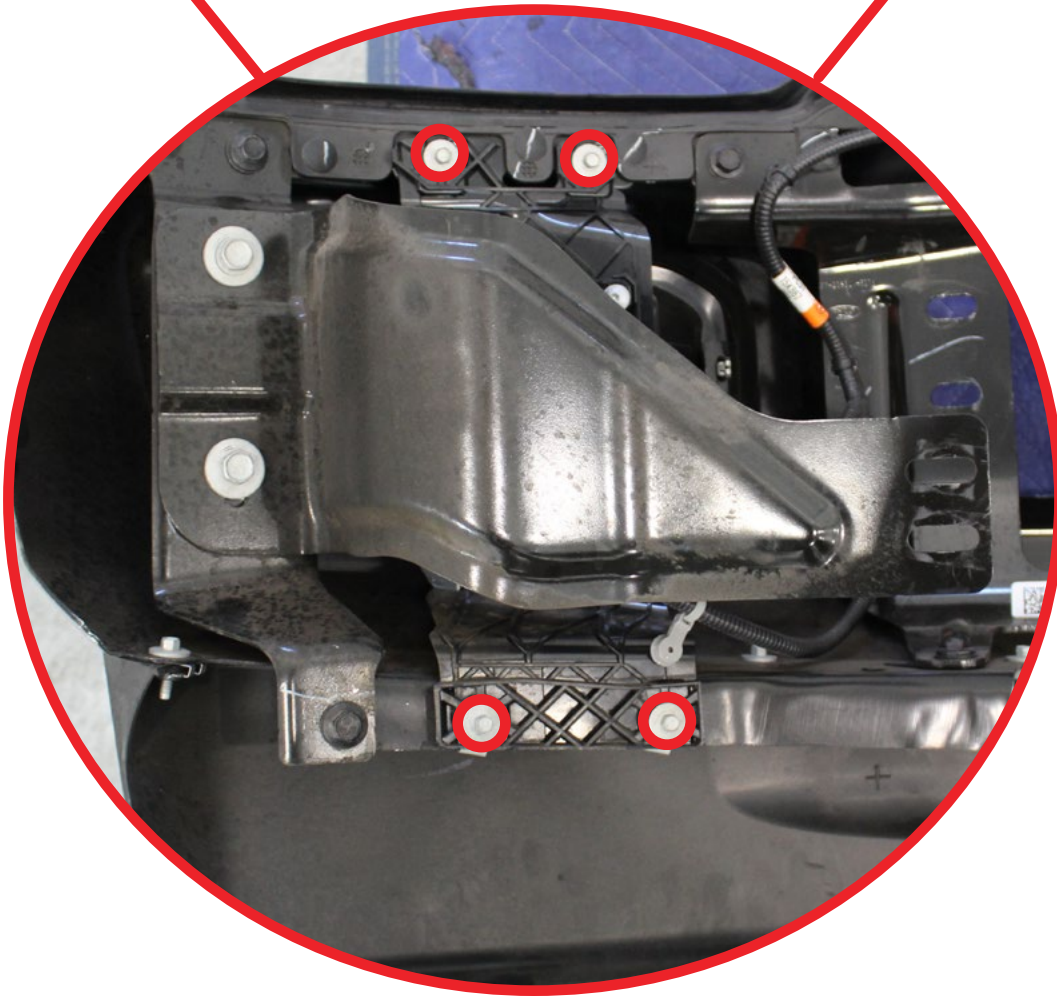
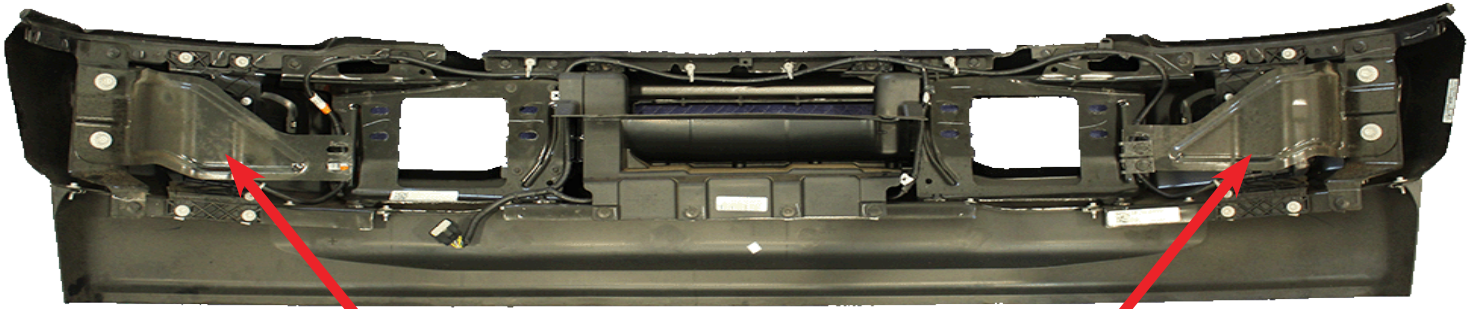

## ADAPTIVE CRUISE CONTROL BRACKET 23+ / FORD SUPER DUTY

## REMOVAL

### □ STEP 8

Unplug the fog light as shown below.

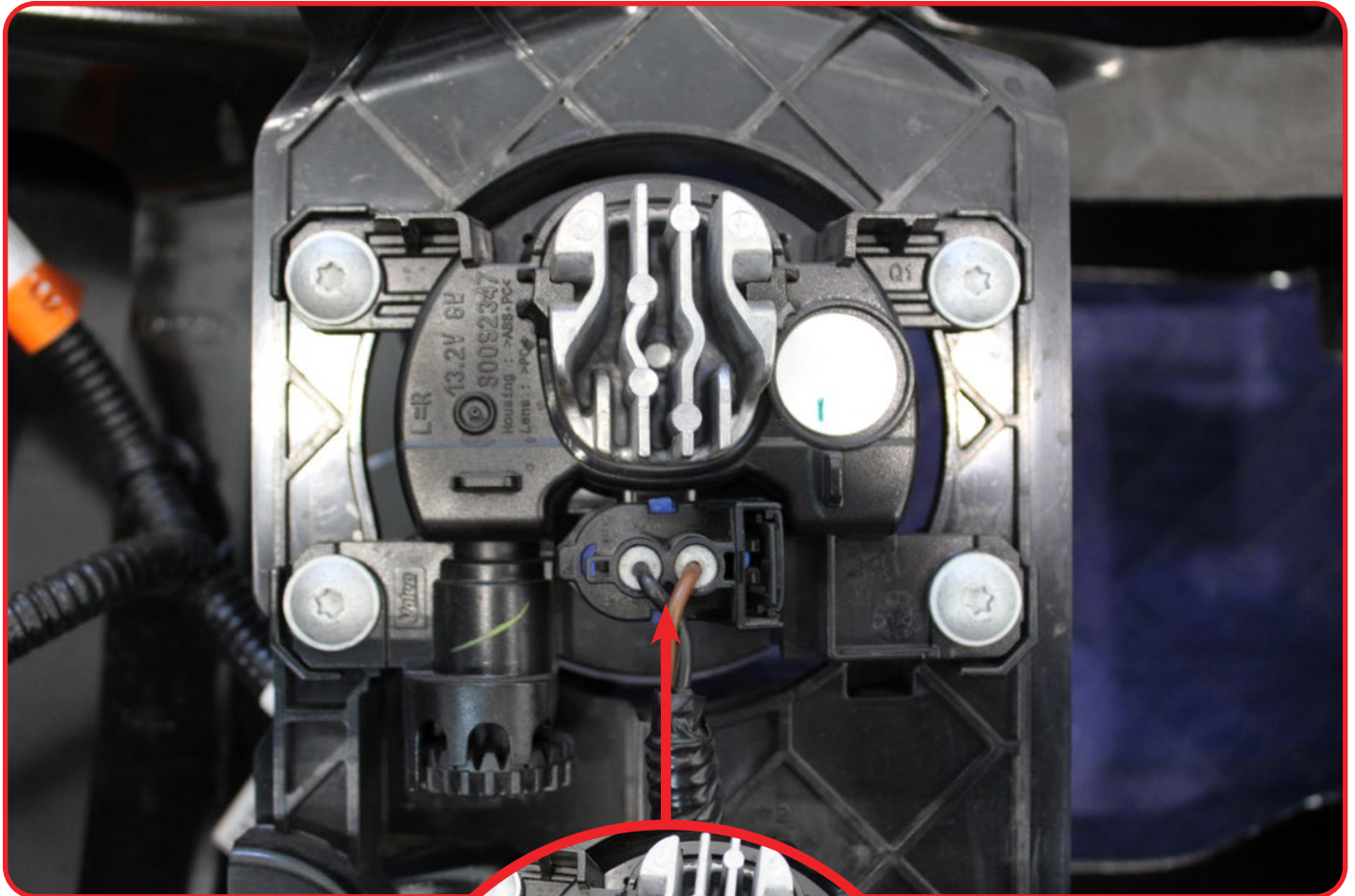

## ADAPTIVE CRUISE CONTROL BRACKET 23+ / FORD SUPER DUTY

## REMOVAL

### □ STEP 9

Remove the 6x bolts as shown below using a (5/16 socket).

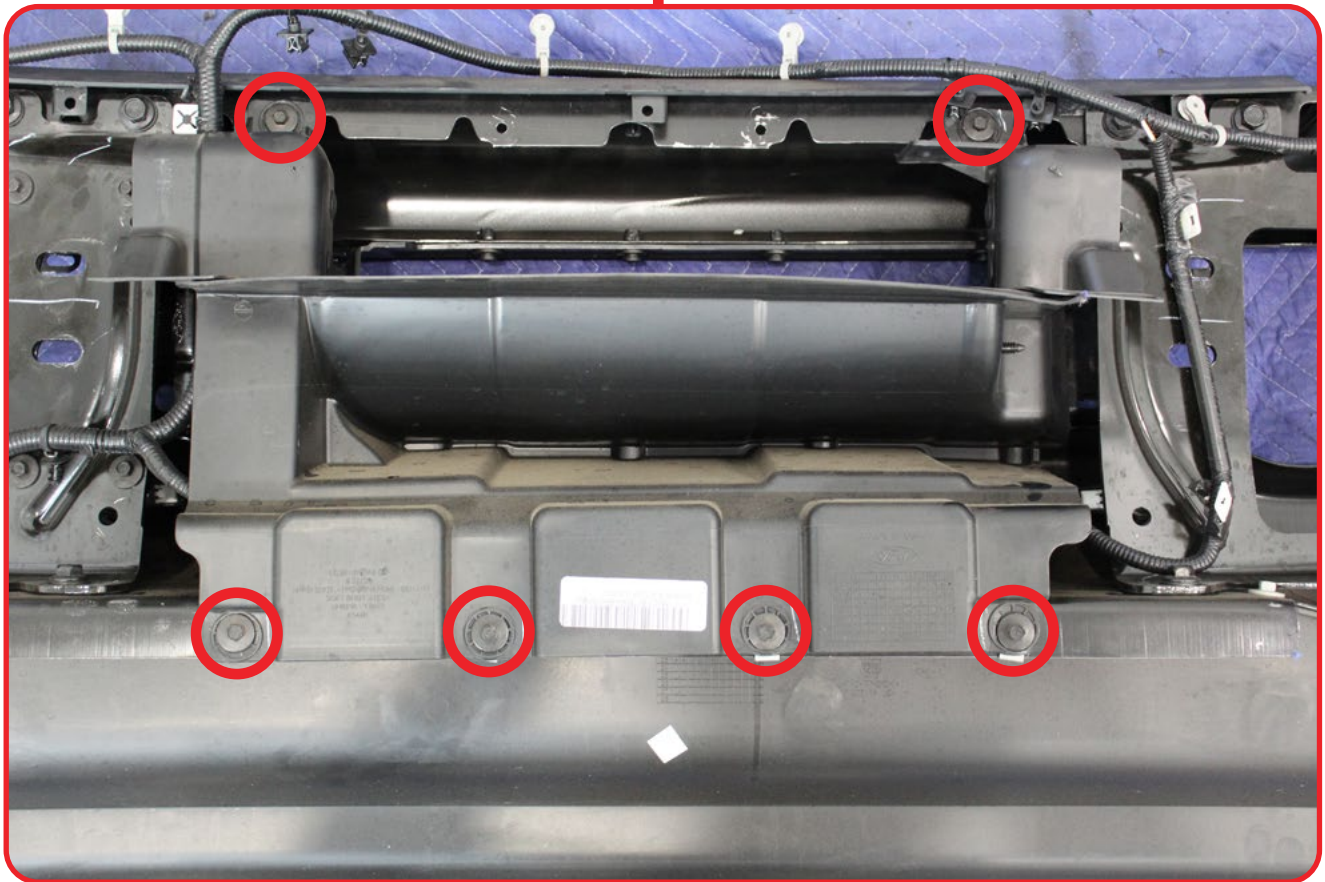
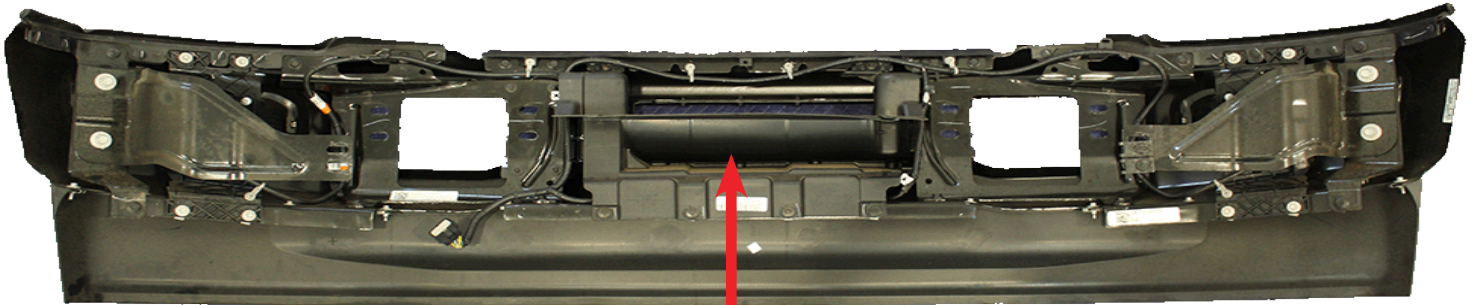

## ADAPTIVE CRUISE CONTROL BRACKET 23+ / FORD SUPER DUTY

## REMOVAL

### □ STEP 10

Remove the sensors from the bezels by spreading the tabs and pulling.

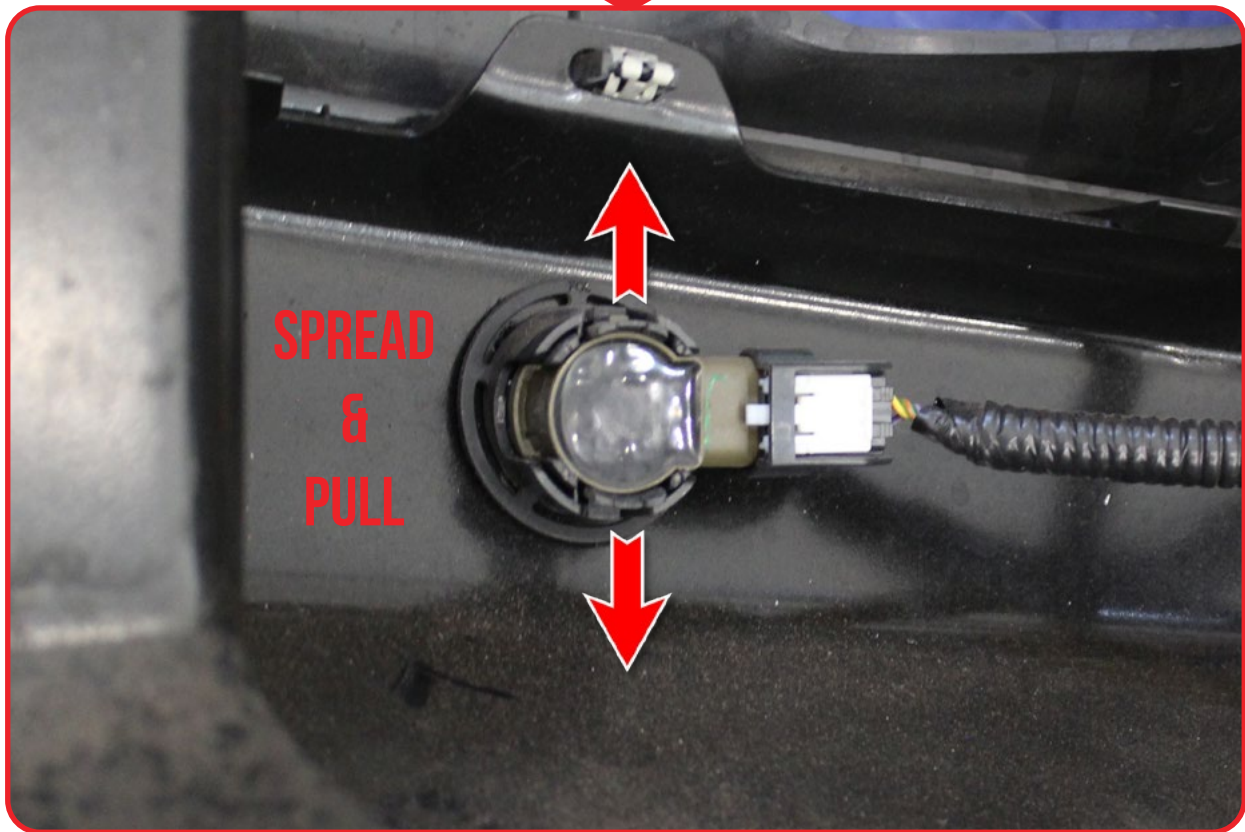
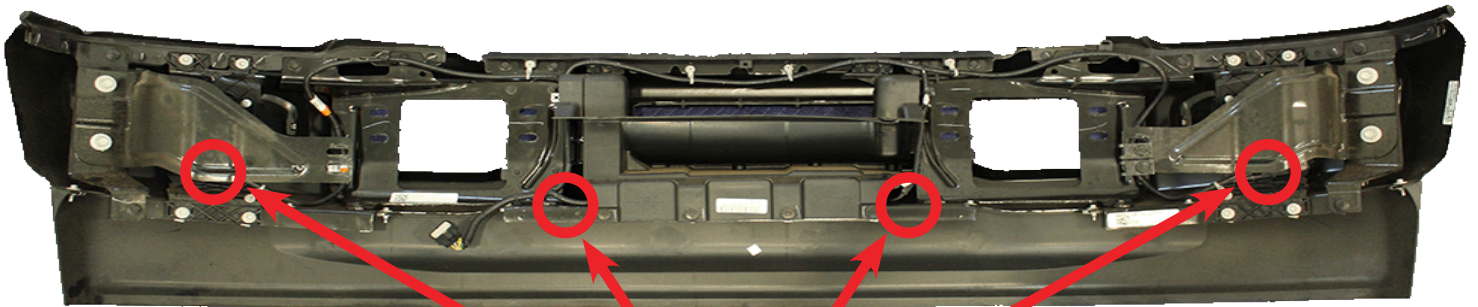

## ADAPTIVE CRUISE CONTROL BRACKET 23+/FORD SUPER DUTY

## REMOVAL

### □ STEP 11

Remove the sensor bezels by pinching the bezel tabs in and pushing out towards the front of the bumper. **\*\*REMEMBER THE ORIENTATION FOR IT WILL BE IMPORTANT LATER IN THE INSTALL\*\***

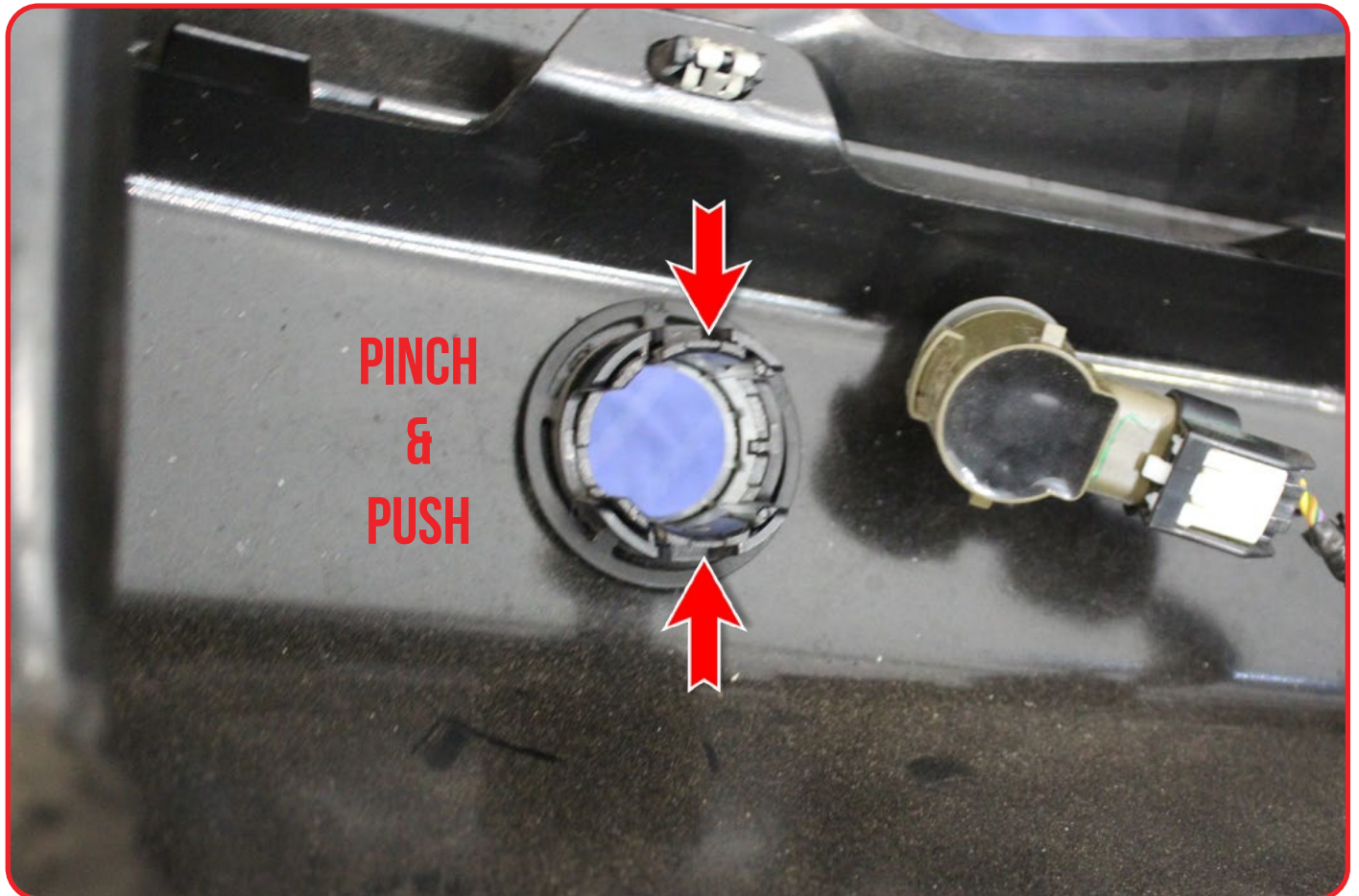

## ADAPTIVE CRUISE CONTROL BRACKET 23+/FORD SUPER DUTY

## REMOVAL

### □ STEP 12

Remove the cap located next to the headlights and remove the bolt using a (10mm socket). (Keep hardware for re-installation)

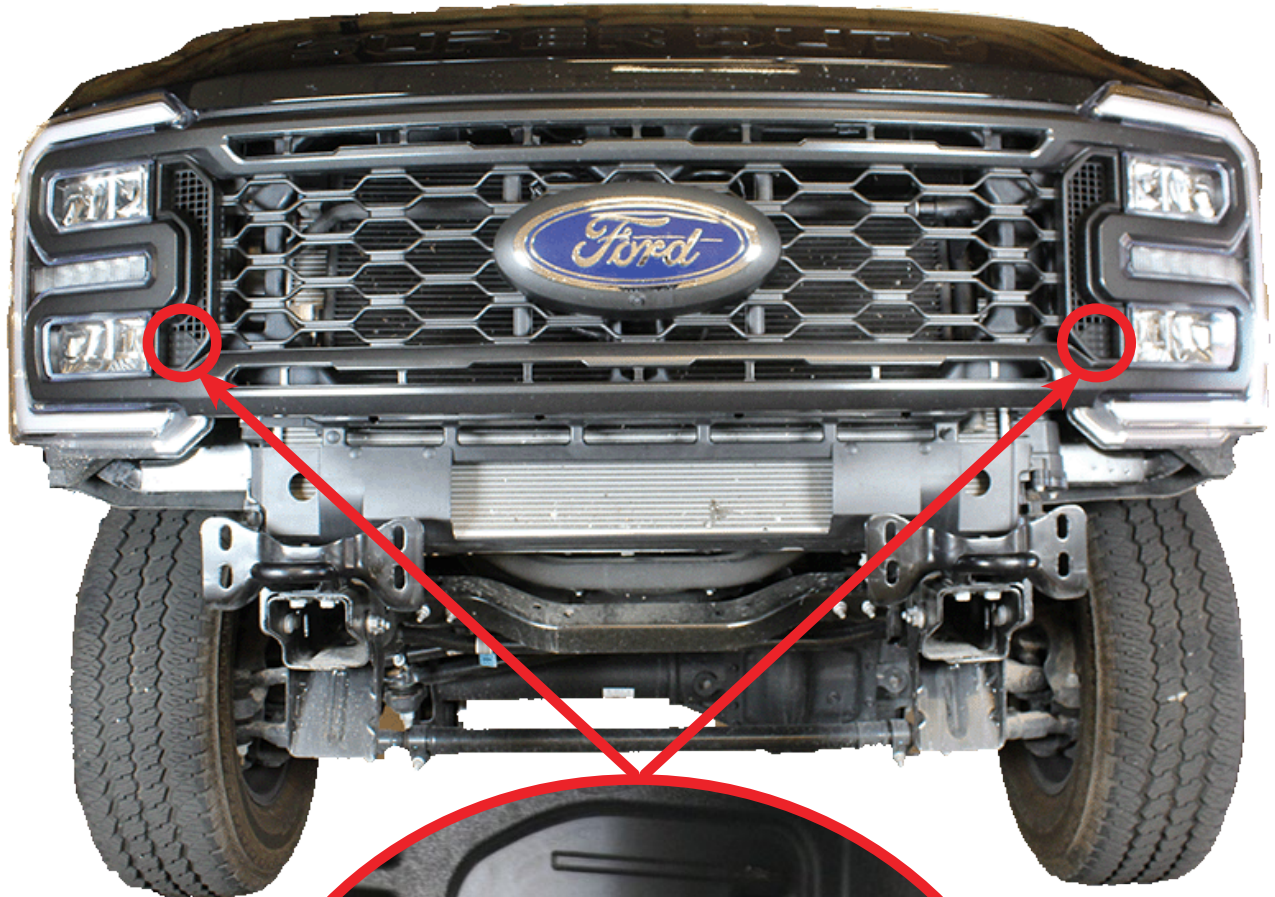

## ADAPTIVE CRUISE CONTROL BRACKET 23+ / FORD SUPER DUTY

## REMOVAL

### □ STEP 13

Remove 11x push clips using a (fastener removal tool). (Keep for they will be using in re-installation)

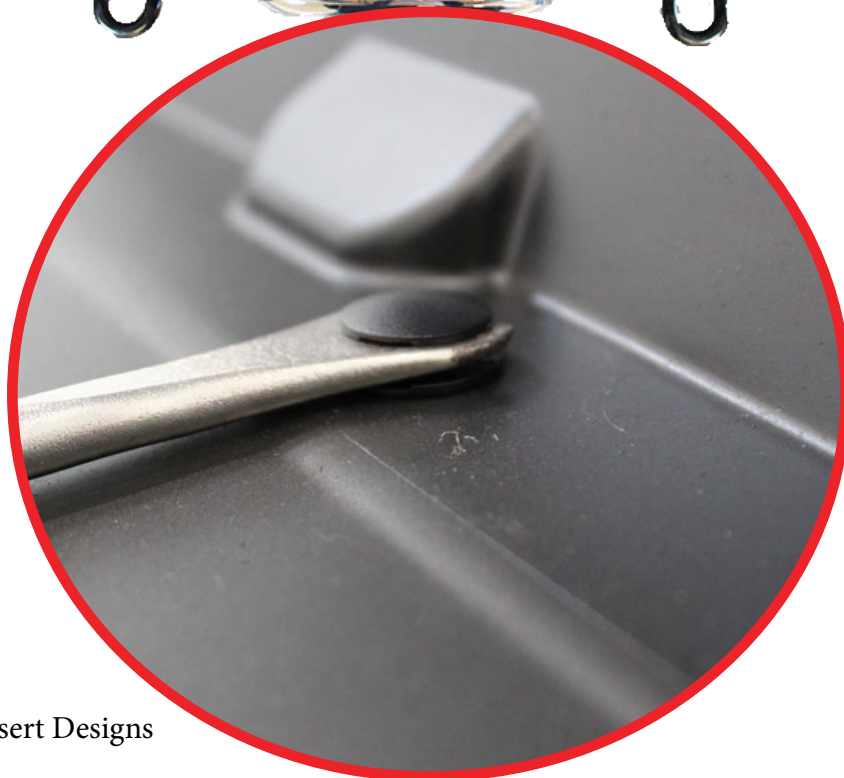
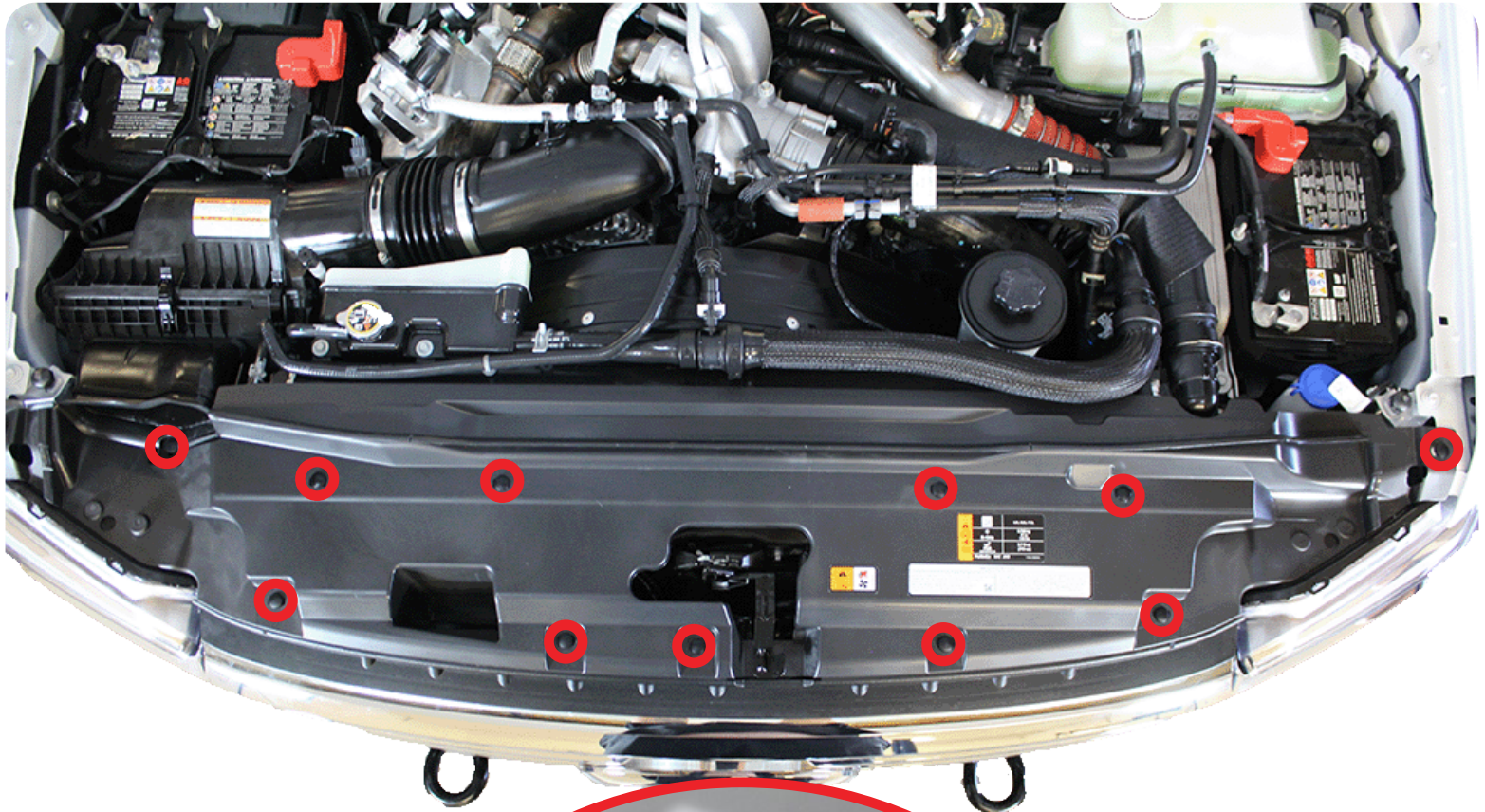

## ADAPTIVE CRUISE CONTROL BRACKET 23+/FORD SUPER DUTY

## REMOVAL

### □ STEP 14

Remove the 4x bolts holding the grill using a (10mm socket) and remove the 2x push pins using a (fastener removal tool). **(Keep hardware for re-installation)**

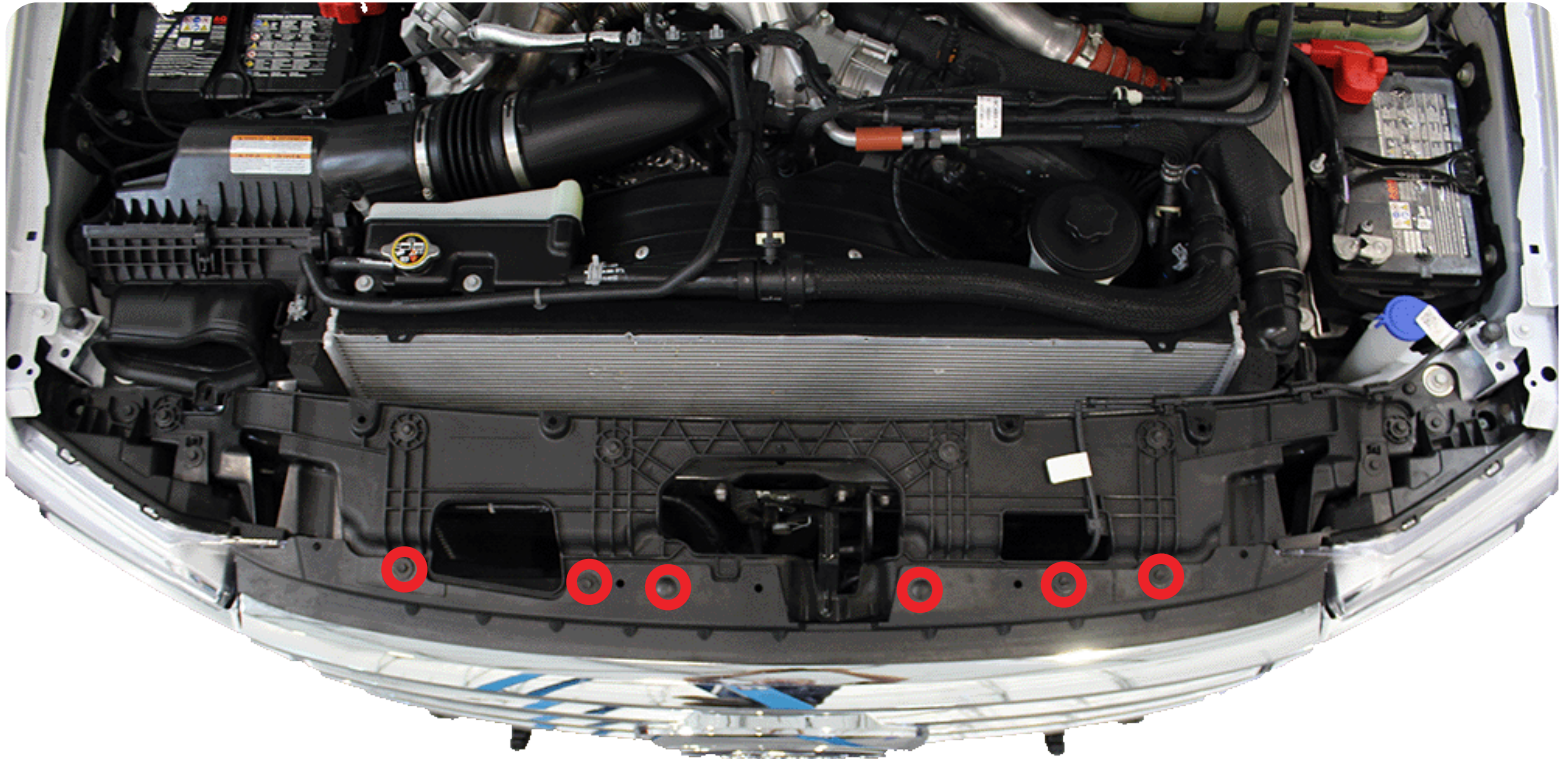

## ADAPTIVE CRUISE CONTROL BRACKET 23+ / FORD SUPER DUTY

## INSTALL

### □ STEP 15

Install the brackets shown below to the ACC module. Next install the backer plate with the provided **(B, B1, B2)** 1/4" hardware using a (5/32 allen) and a (7/16 wrench).

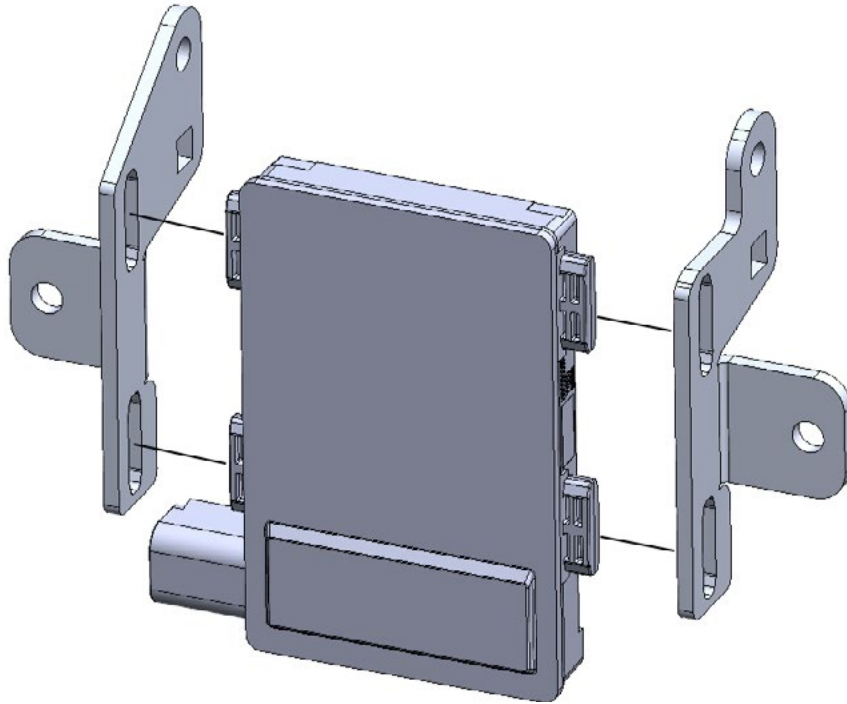

**B.**  
**B1.**  
**B2.**

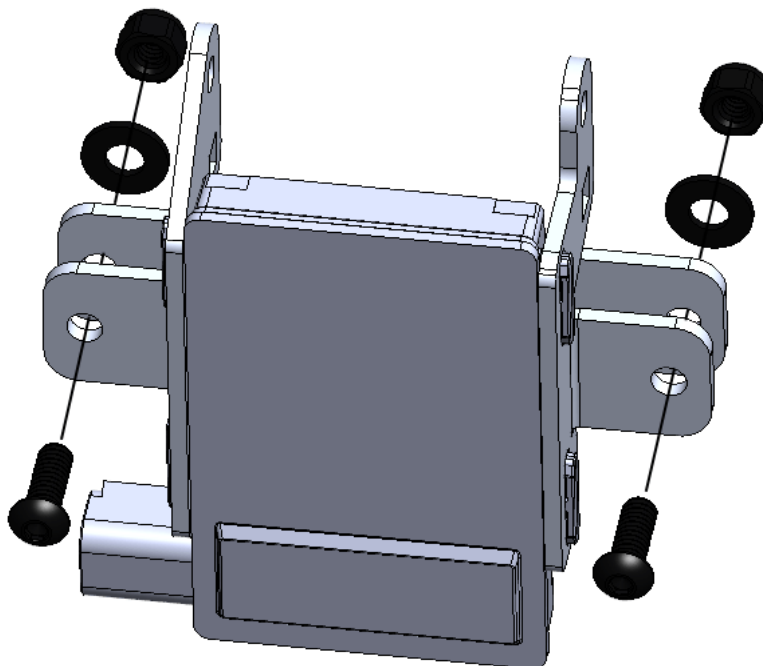

## ADAPTIVE CRUISE CONTROL BRACKET 23+ / FORD SUPER DUTY

### INSTALL

#### □ STEP 16

Install the ACC module to the mounting bracket as shown below with the provided hardware (**B, B1, B2**) with a (5/32 allen) and a (7/16 wrench). For best results, mount the sub assembly from **step 15** in the bottom position with the plug down and towards the center of the truck. If obstruction (such as top hoop or lights) are to be mounting in a position in front of the sensor, mount the sub assembly from **step 15** in the top position as shown below.

**\*\*Ensure to not over tighten so you can make angle adjustments later on in the install\*\***

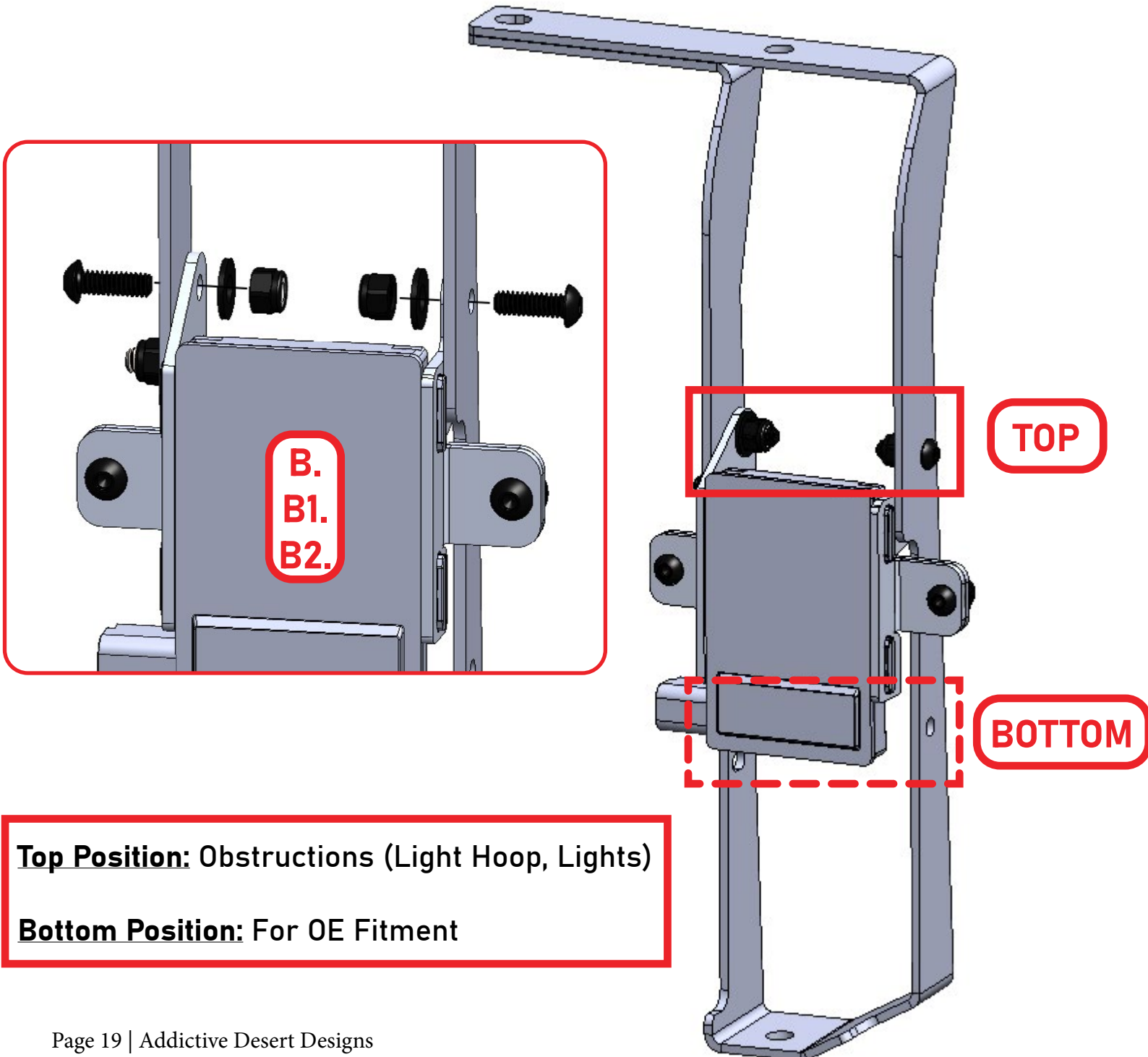

## ADAPTIVE CRUISE CONTROL BRACKET 23+/FORD SUPER DUTY

## INSTALL

### □ STEP 17

Install the provided **(C, B1, B2)** 1/4" hardware using a (7/16 wrench) into the mounting hole shown below.

**\*\*Ensure to not over tighten so you can make angle adjustments later on in the install\*\***

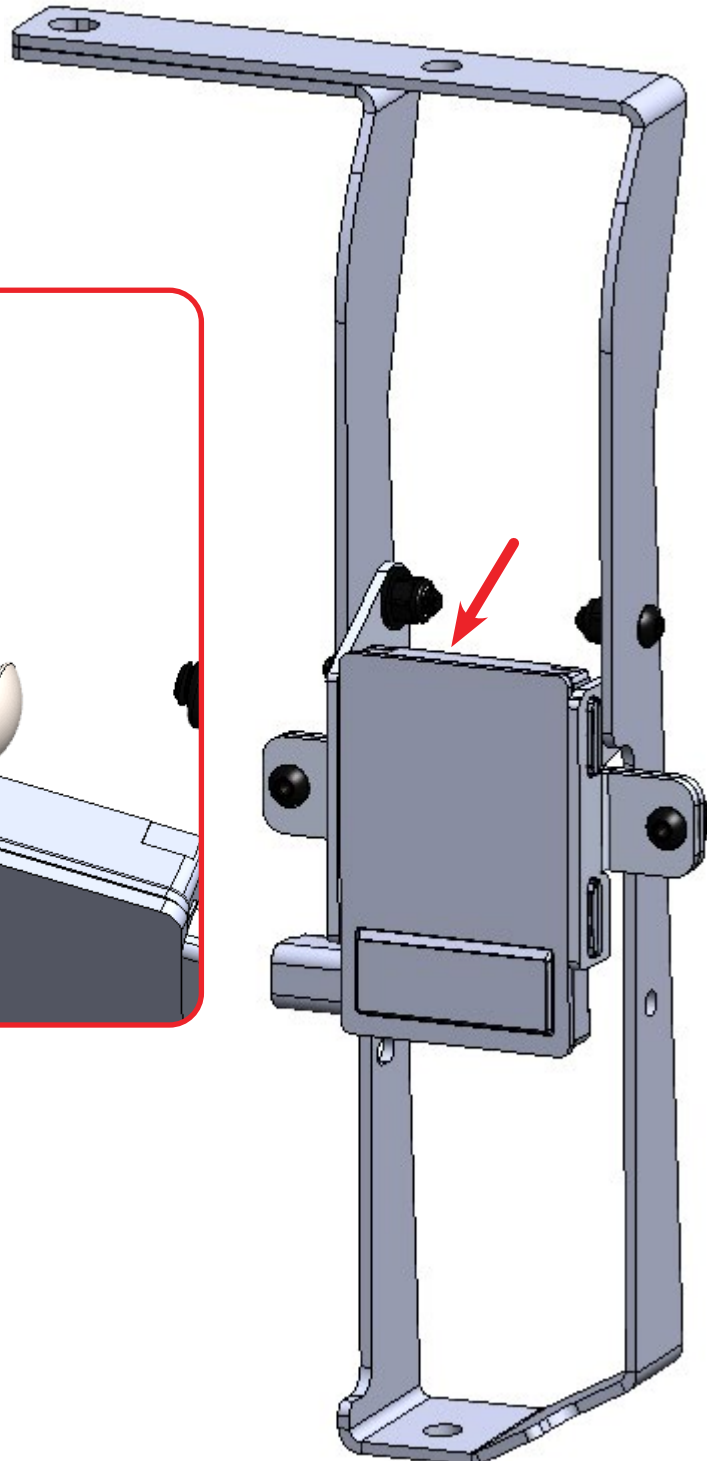
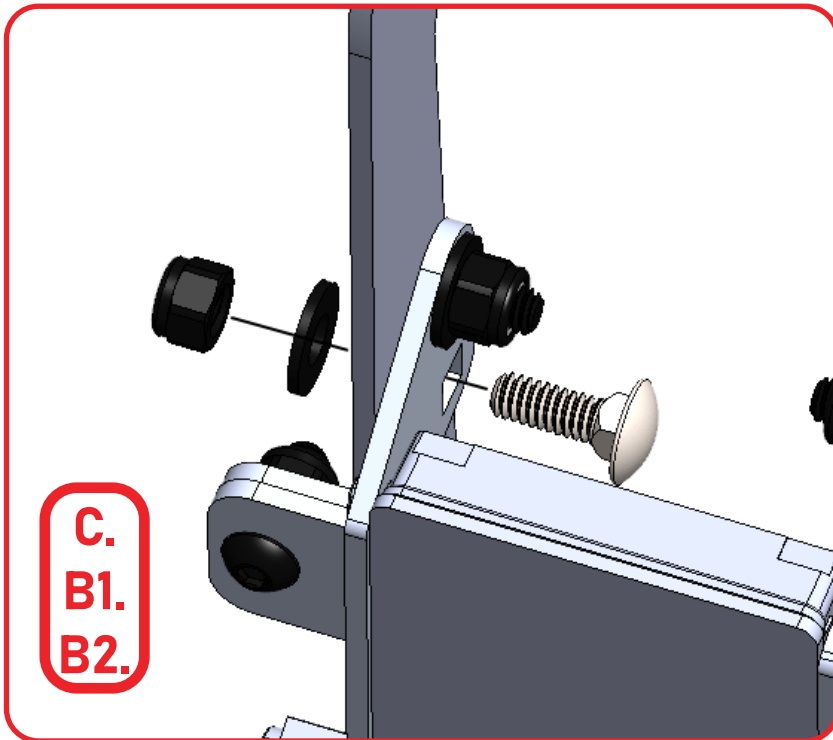

## ADAPTIVE CRUISE CONTROL BRACKET 23+ / FORD SUPER DUTY

## INSTALL

### □ STEP 18

Place the bracket on the driver side and mark the hole. **\*\*Ensure that the back edge of the bracket lines up with the back of the grill support and the bend is placed against the radius\*\***

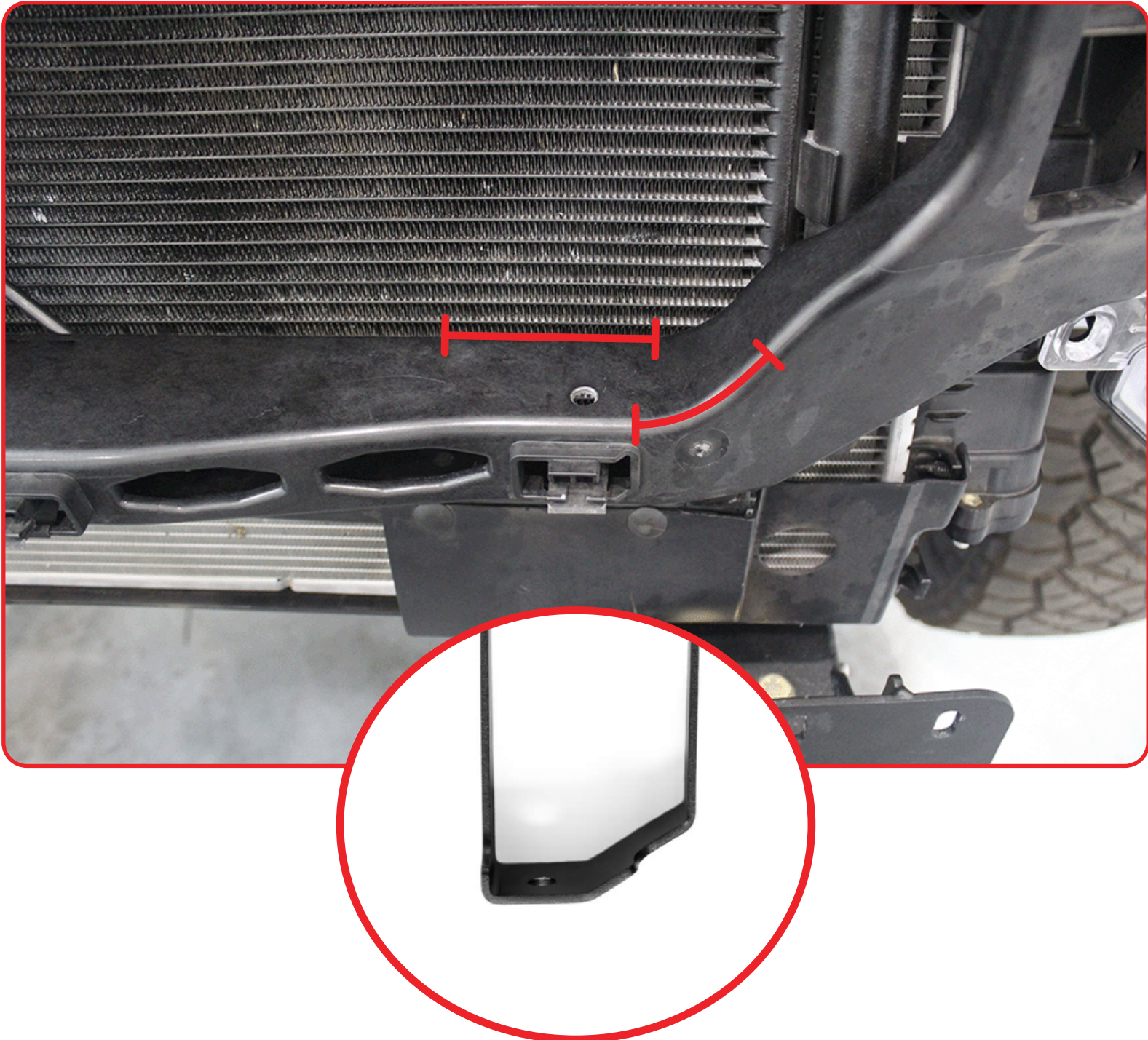

## ADAPTIVE CRUISE CONTROL BRACKET 23+ / FORD SUPER DUTY

## INSTALL



## ADAPTIVE CRUISE CONTROL BRACKET 23+ / FORD SUPER DUTY

## INSTALL

### □ STEP 19

Drill the marked hole using a (13/32 drill bit) and mount the bracket with the provided hardware (**A**, **A1**, **A2**) using a (7/32 allen) and a (9/16 wrench).

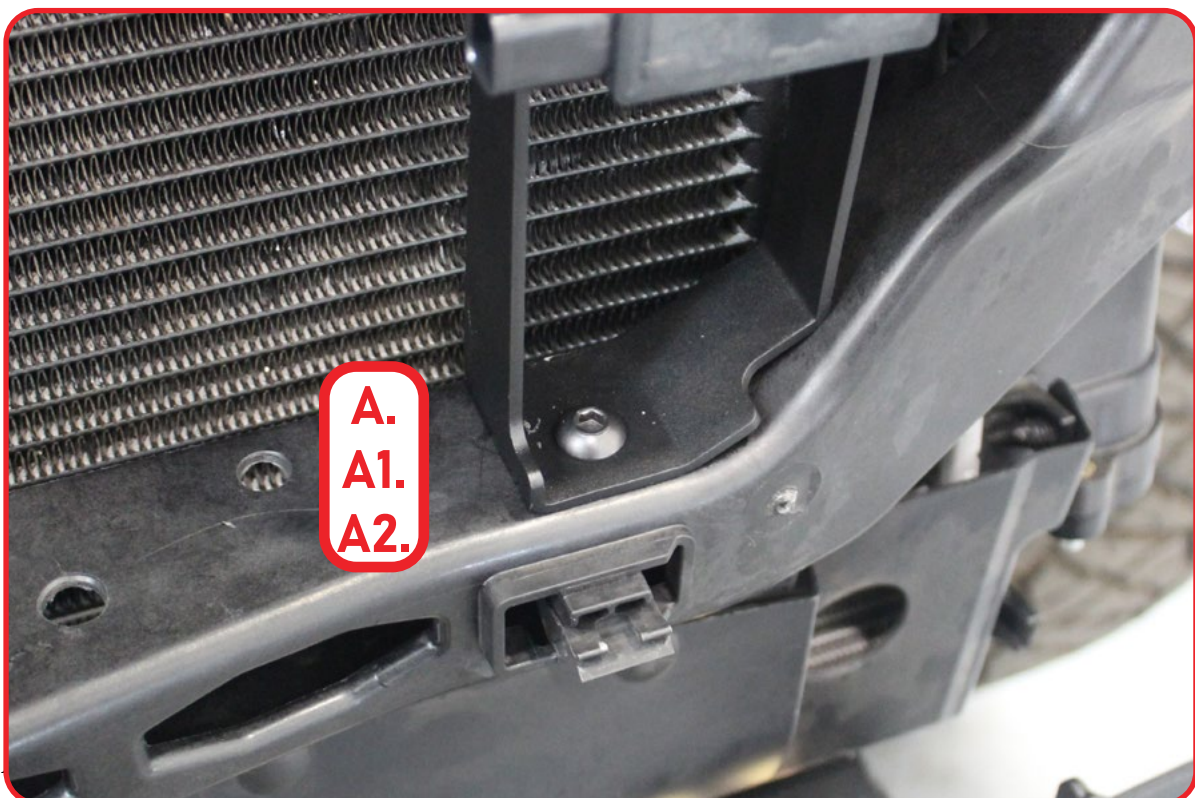

## ADAPTIVE CRUISE CONTROL BRACKET 23+ / FORD SUPER DUTY

## INSTALL

### □ STEP 20

Mark the top holes and remove the bracket. Drill the holes using a (13/32 drill bit) and re-install the bracket and install the provided hardware (**A, A1, A2**) using a (7/32 allen) and a (9/16 wrench).



## ADAPTIVE CRUISE CONTROL BRACKET 23+ / FORD SUPER DUTY

## INSTALL

### □ STEP 21

Using an (angle finder), zero out on flat ground and place on the sensor face itself to ensure the angle is 90 degrees before re-installing the grill. If not, loosen the mounting hardware and adjust as needed.

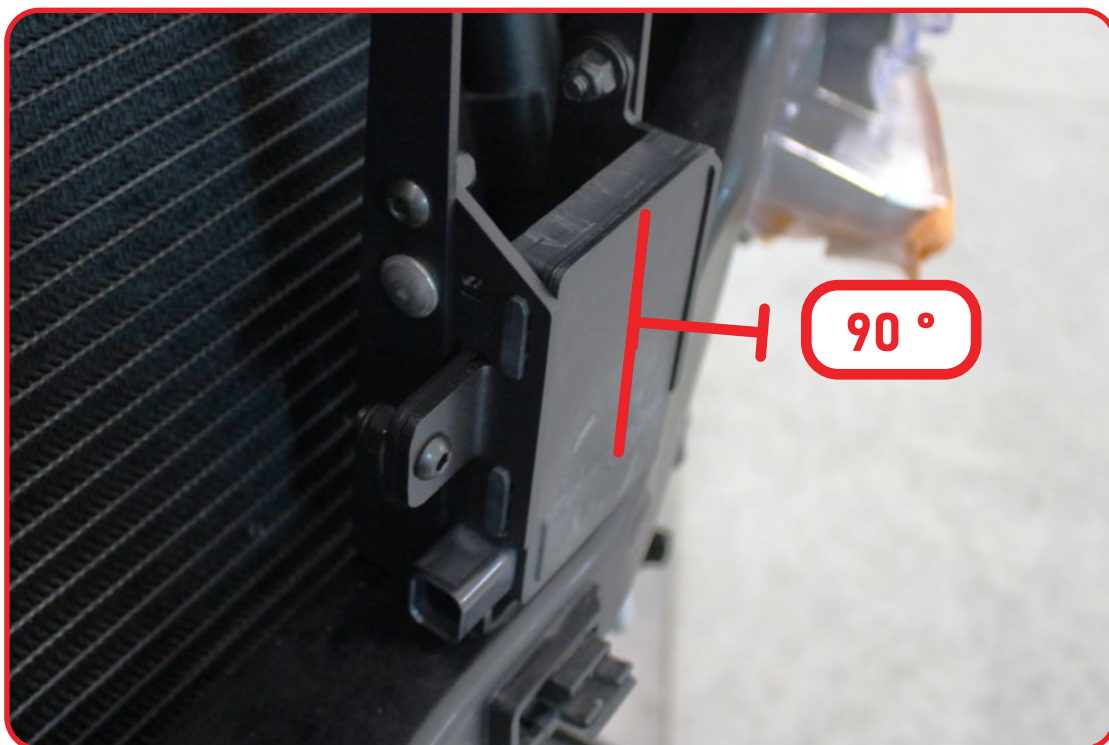

## ADAPTIVE CRUISE CONTROL BRACKET 23+ / FORD SUPER DUTY

## INSTALL

### □ STEP 22

Find the section of the wire harness that goes to the adaptive cruise control bracket. Remove the wire loom from this point all the way back to the main connector so you can separate the adaptive cruise wires from the rest of the harness. Once you have all the wires separated re-loom the exposed wire.



Strip back the wire loom starting at this connector and ending at the main harness connector so it looks like below when you are complete.

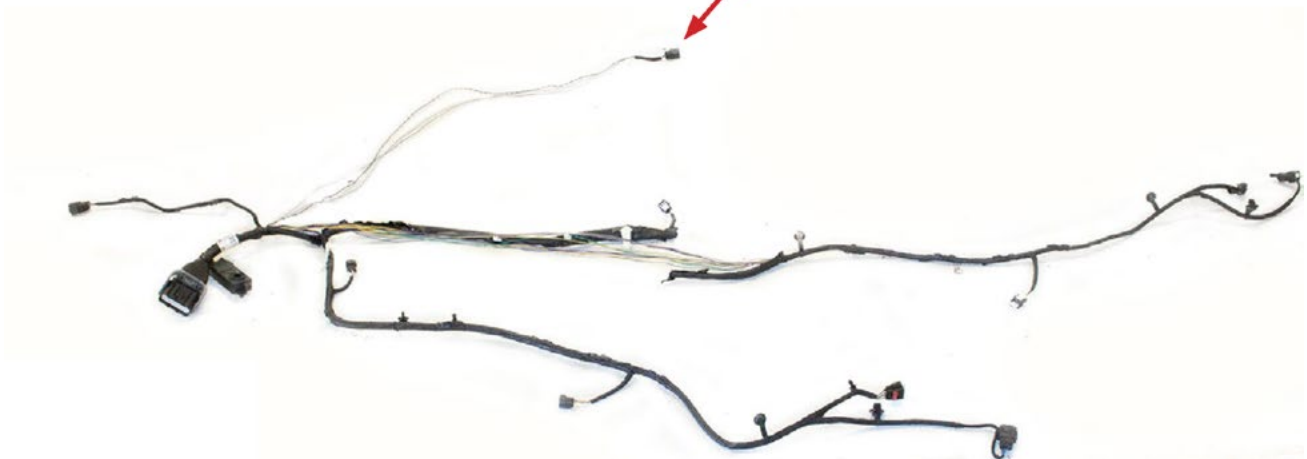

## ADAPTIVE CRUISE CONTROL BRACKET 23+ / FORD SUPER DUTY

## INSTALL

### □ STEP 23

Install the 4x bolts for the grill using a (10mm socket) and install the 2x push pins.

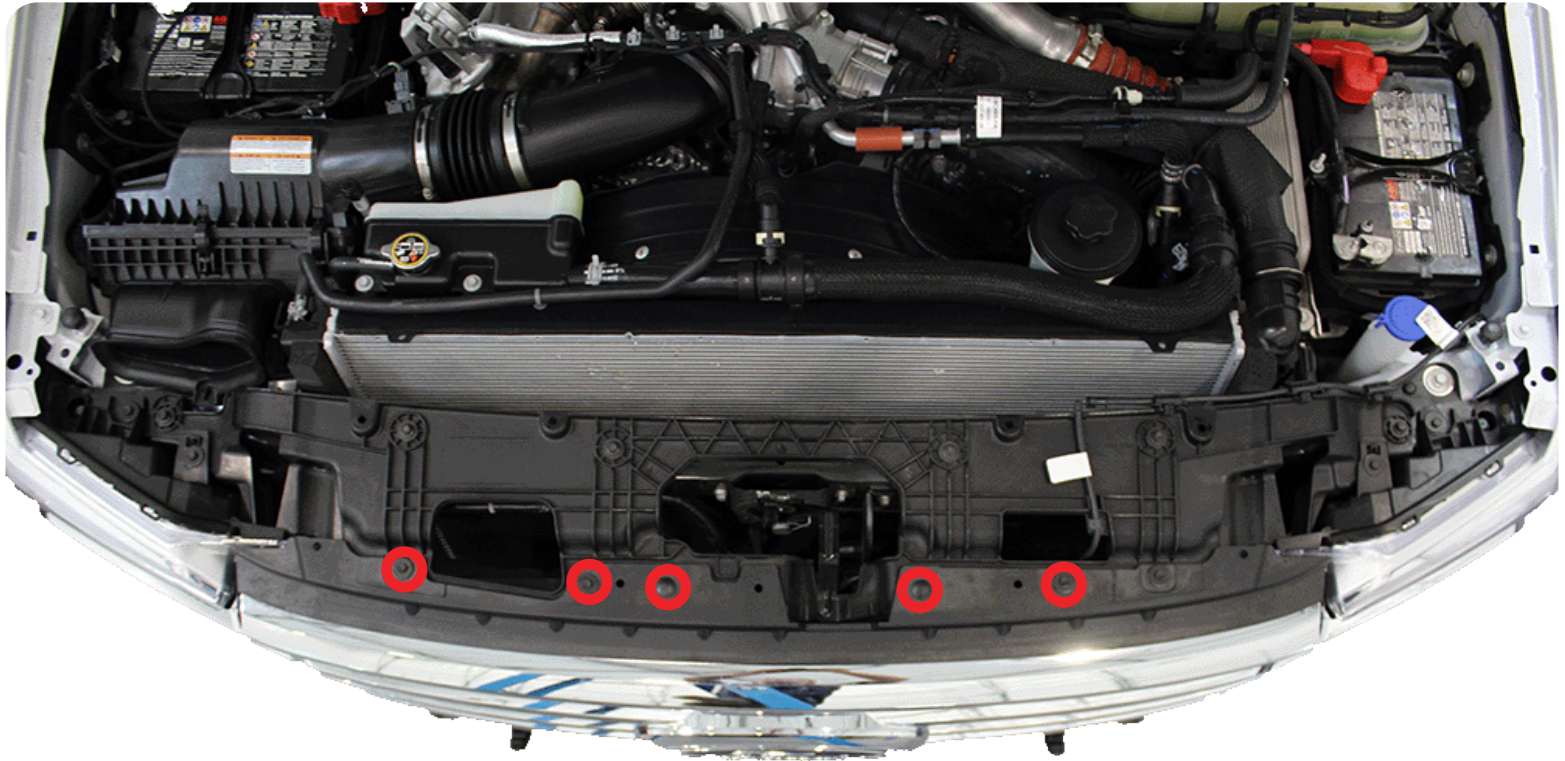

## ADAPTIVE CRUISE CONTROL BRACKET 23+ / FORD SUPER DUTY

## INSTALL

### □ STEP 24

Install the 11x push clips.

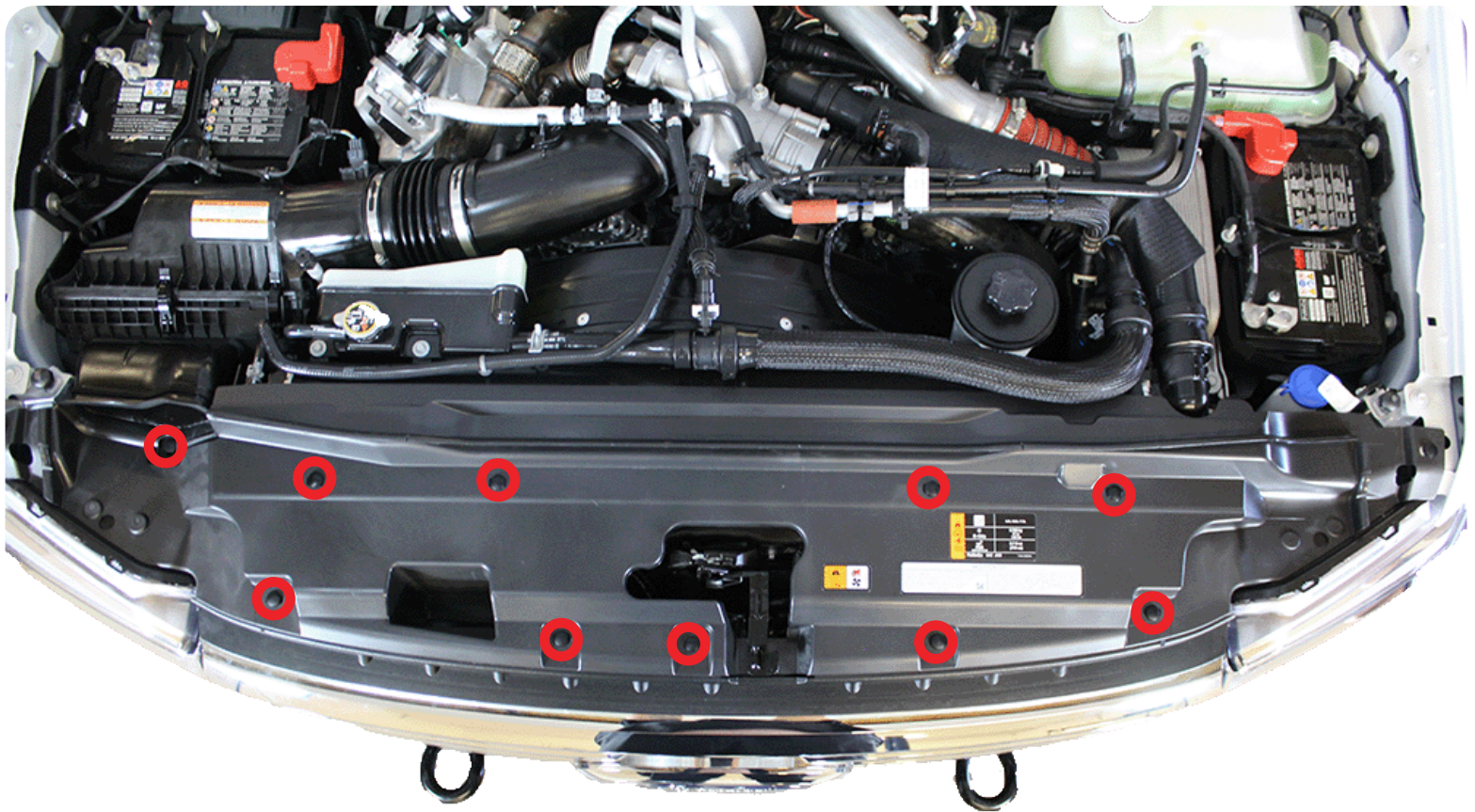

## ADAPTIVE CRUISE CONTROL BRACKET 23+/FORD SUPER DUTY

## INSTALL

### □ STEP 25

Install the 2x bolts using a (10mm socket) and re-install the cap.

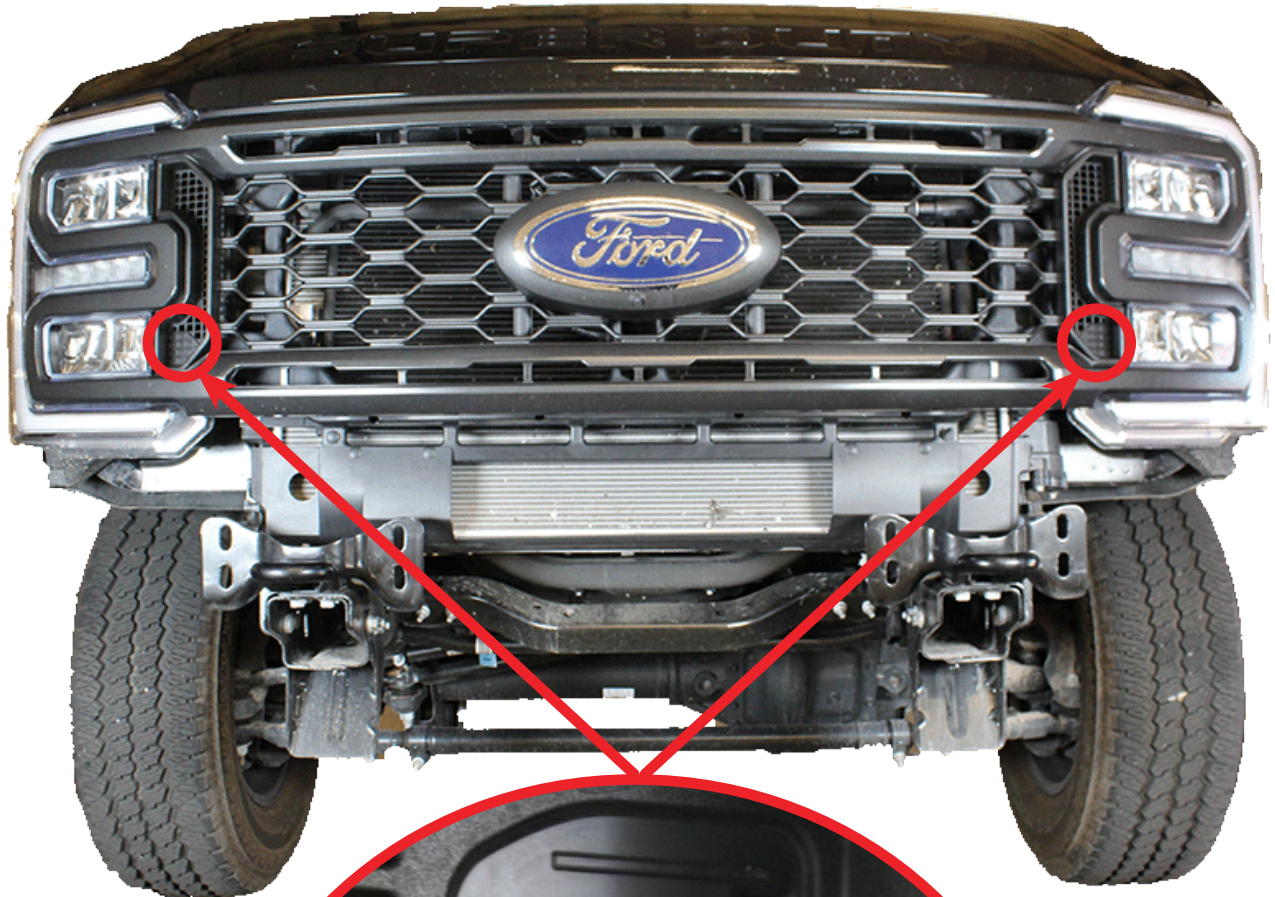

## ADAPTIVE CRUISE CONTROL BRACKET 23+/FORD SUPER DUTY

# FINAL

### □ STEP 26

Stand back and enjoy your new ADD Adaptive Cruise Control Bracket.

Check and re-tighten, if needed, all mounting bolts after 100 miles and periodically thereafter.



THIS PRODUCT IS PROTECTED BY ONE OR MORE U.S. PATENTS  
[WWW.ADDICTIVEDESERTDESIGNS.COM/PATENTS](http://WWW.ADDICTIVEDESERTDESIGNS.COM/PATENTS)

FOR ADDITIONAL SUPPORT OR TECHNICAL QUESTIONS,  
PLEASE CALL 480-671-0820 OR  
EMAIL [INFO@ADDICTIVEDESERTDESIGNS.COM](mailto:INFO@ADDICTIVEDESERTDESIGNS.COM)