



VOLKSWAGEN MKVII

FRONT APPLICATION

Kit 76003

For maximum effectiveness and safety, please read these instructions completely before proceeding with installation.

Failure to read these instructions can result in an incorrect installation which could result in damage to the vehicle, minor to severe personal injury or death.

Protect your Air Lift Performance Purchase by Completing your Warranty Registration



Thank you for purchasing an Air Lift Performance product!

Take a photo of your sales receipt and then scan the
QR code to complete your online warranty registration.

TABLE OF CONTENTS

P.02

Introduction

Notation Explanation

P.03

System Overview

Hardware Content

P.04

Install the System

Important Safety Notices

Section 1. Prepare the Vehicle

Section 2. Stock Suspension Removal

Section 3. Install the Kit Components

Section 4. Route the Air Lines

P.11

Before Operating

Set the Ride Height

Torque Specifications

Suggested Driving Air Pressure

Maximum Air Pressure

Check for Binding

Installation Checklist

Damping Adjustment

P.13

Limited Warranty and Return Policy

Warranty Registration & Claims

Introduction

Air Lift Performance thanks you for purchasing the most complete, fully engineered high-performance air suspension made for the Volkswagen MKVII platform. Read these installation instructions to correctly and safely set up the vehicle for a #lifeonair.

Air Lift assumes that the installer has the mechanical knowledge and ability to work on vehicle suspension systems and has basic tools necessary to complete a suspension replacement project. Special tools needed to complete the installation are noted on the System Overview page.

Air Lift reserves the right to make changes and improvements to its products and publications at any time. For the latest version of this manual, contact Air Lift Performance at **(800) 248-0892** or visit **www.airliftperformance.com**.

An Air Lift Performance air management system is highly recommended for this product. Learn more at **air-lift.co/productlines**.

NOTATION EXPLANATION

Hazard notations appear in various locations in this publication. Information highlighted by one of these notations must be observed to help minimize risk of personal injury or possible improper installation, which may render the vehicle unsafe. Notes are used to help emphasize areas of procedural importance and provide helpful suggestions. The following definitions explain the use of these notations as they appear throughout this guide.



DANGER

INDICATES IMMEDIATE HAZARDS WHICH WILL RESULT IN SEVERE PERSONAL INJURY OR DEATH.



WARNING

INDICATES HAZARDS OR UNSAFE PRACTICES WHICH COULD RESULT IN SEVERE PERSONAL INJURY OR DEATH.



CAUTION

INDICATES HAZARDS OR UNSAFE PRACTICES WHICH COULD RESULT IN DAMAGE TO THE VEHICLE OR MINOR PERSONAL INJURY.



NOTE

Used to help emphasize areas of procedural importance and provide helpful suggestions.



TECH TIP

Used to provide helpful tips to ease the installation process.

System Overview

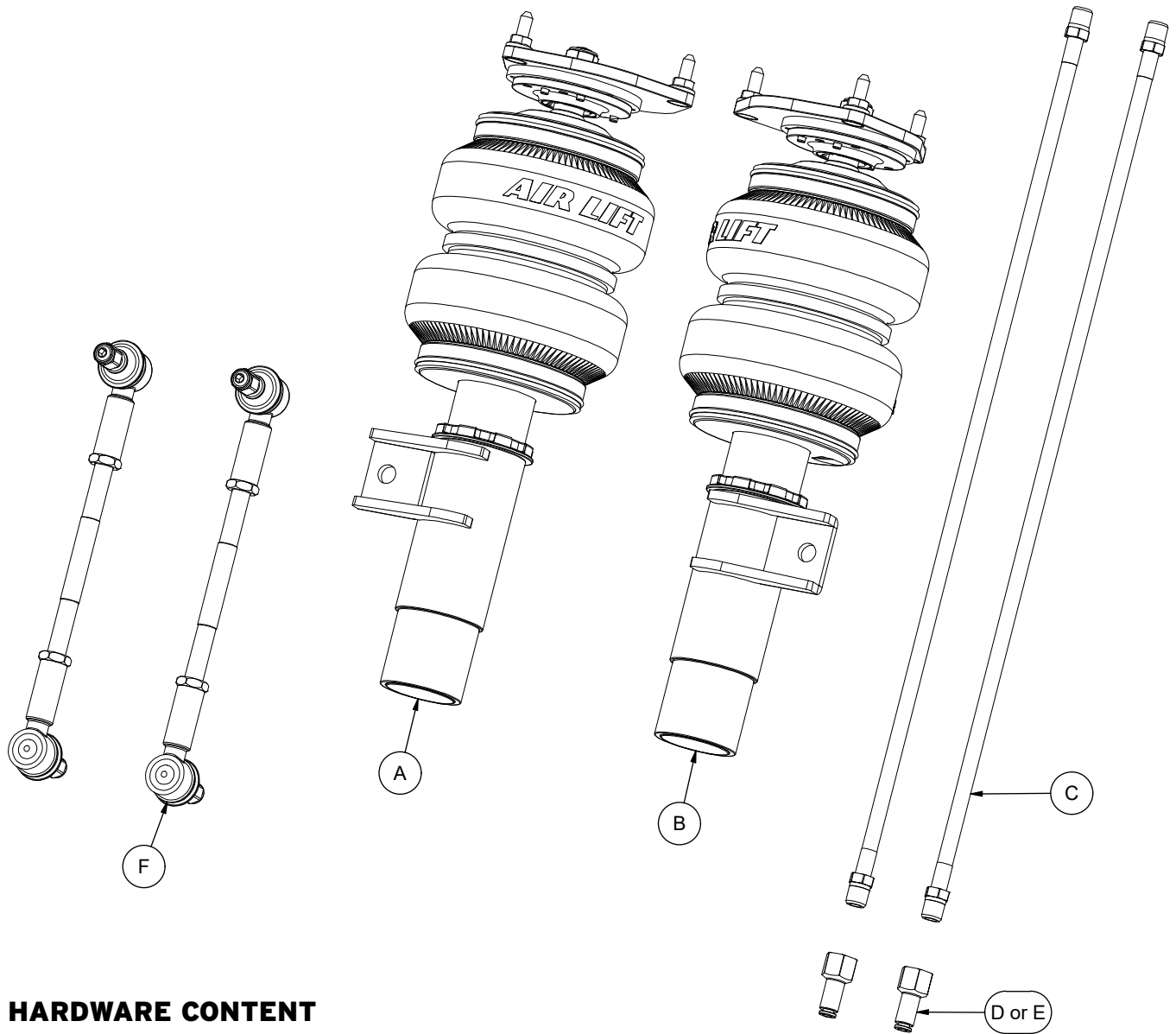

HARDWARE CONTENT

Item	Part #	Description	Qty
A	35715	STRUT ASSEMBLY, MK7 LF	1
B	35714	STRUT ASSEMBLY, MK7 RF	1
C	20997	LEADER LINE, 1/4" ID	2
D	21810	1/4" FNPT X 1/4" PTC FITTING, DOT	2
E	21987	1/4" FNPT X 3/8" PTC FITTING, DOT	2
F	76002-001	ADJUSTABLE END LINK	2

Fig. 1



Missing or damaged parts? Call Air Lift customer service at (800) 248-0892 for a replacement part.

Install the System



NOTES

See important safety notices on page 2.

SECTION 1. PREPARE THE VEHICLE

1. Elevate and support the vehicle with a hoist or safety stands.
2. Remove the front wheel and support the hub assembly (Fig. 2).



Fig. 2

SECTION 2. STOCK SUSPENSION REMOVAL

1. Within the engine compartment, remove the weather stripping from the plastic cowl cover (Figs. 3 & 4).



Fig. 3

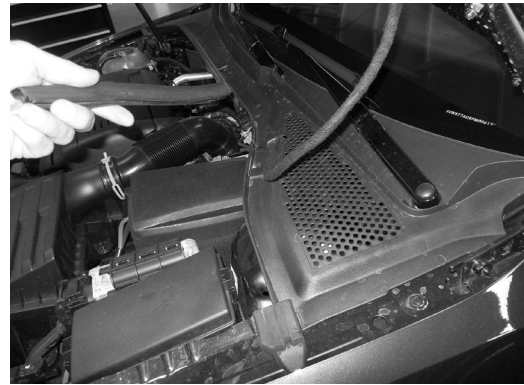

Fig. 4

2. Remove both wiper arms (Figs. 5-7).



Fig. 5



Fig. 6



Fig. 7

3. Unclip the hose from the cowl cover and remove both sections of cover from the vehicle (Figs. 8-11).



Fig. 8

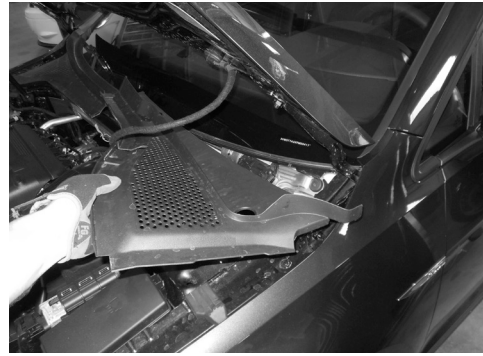

Fig. 9



Fig. 10



Fig. 11

4. Remove the stabilizer bar end link from the strut and bar (Figs. 12-15).



Fig. 12



Fig. 13

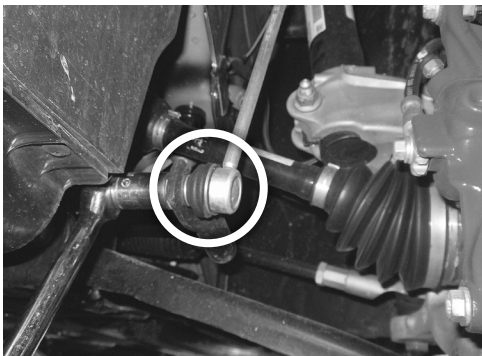

Fig. 14



Fig. 15

5. Remove the axle bolt from the bearing hub (Figs. 16 & 17).



Fig. 16

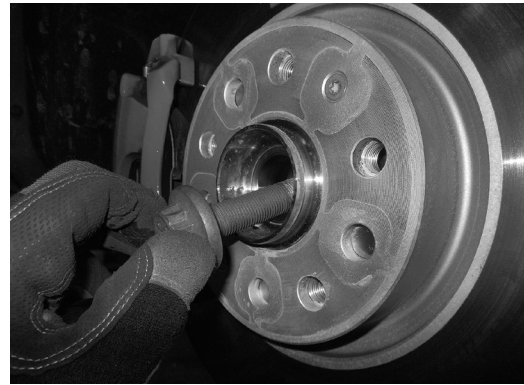

Fig. 17

6. Remove the lower strut pinch bolt (Fig. 18).

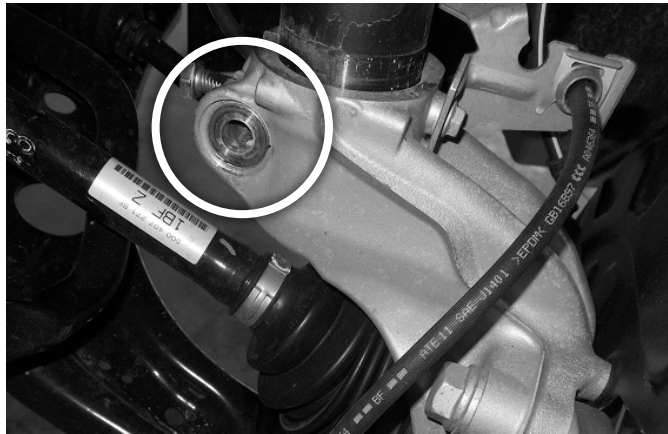

Fig. 18

7. Support the hub assembly and remove the three lower ball joint bolts (Fig. 19).



Fig. 19

- Rotate the hub and remove the axle from the bearing. Support the axle and slide the hub down from the strut (Fig. 20).

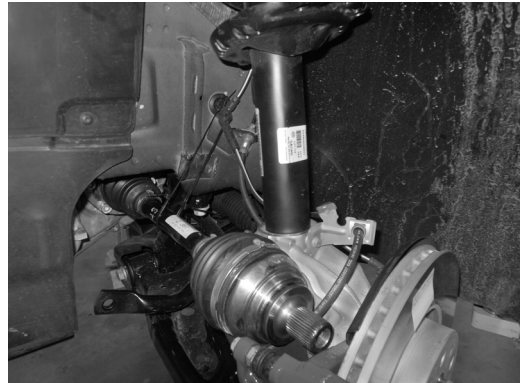

Fig. 20

- Unbolt the three upper strut mount bolts and remove the strut from the vehicle (Figs. 21 & 22).

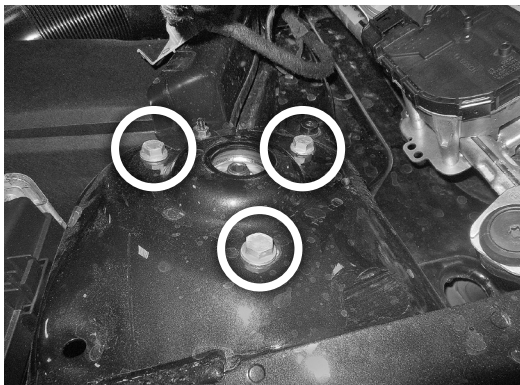

Fig. 21



Fig. 22

- Insert the axle through the bearing (Fig. 23), reattach the axle bolt and three lower ball joint nuts (Fig. 24). Torque ball joint nuts to 60Nm (44 lb.-ft.). Thread the axle bolt in place (Fig. 25). See torque specifications (page 12) for axle bolt values.

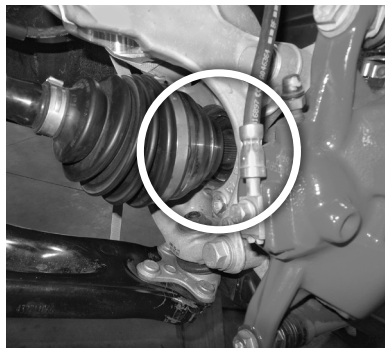

Fig. 23



Fig. 24



Fig. 25

SECTION 3. INSTALL THE KIT COMPONENTS



PLEASE READ - IMPORTANT INSTALLATION INFORMATION



FOR COIL TO AIR UPGRADE KIT INSTALLATIONS ONLY: Please refer to the included Coil to Air Upgrade Kit installation guide (MN-2000) for details on how to disassemble the coilovers and assemble the air springs.

Also refer to your control system installation guide to ensure the installation of your air suspension system is complete.



NOTES

All dampers come pre-set to even lengths, and locking collars are pre-tightened. It is always recommended to double-check that the dampers are the same length side to side, and the locking collars are tight.

Please refer to the User Guide included with the kit for any suspension setup adjustments.

1. Begin by installing the leader line into the air spring. Tighten the appropriate fitting to the air line (1 3/4 turns beyond hand-tight). Tighten the leader line into the air spring 1 3/4 turns beyond hand-tight (Fig. 26).

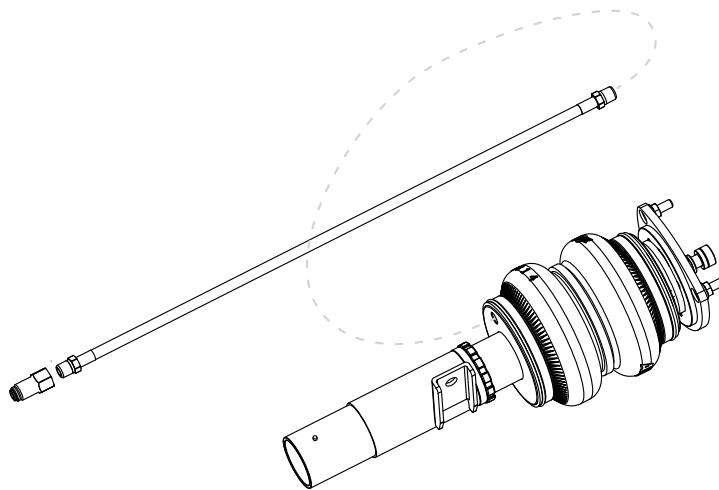
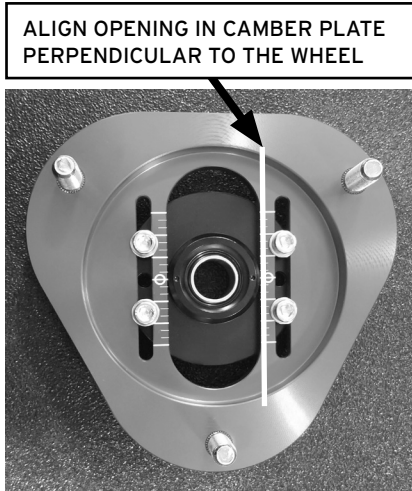

Fig. 26

2. Attach the strut camber plate to the chassis (Figs. 27 & 28). Torque nuts to 27Nm (20 lb.-ft.).



Fig. 27



Shown above is a representative image of a camber plate.

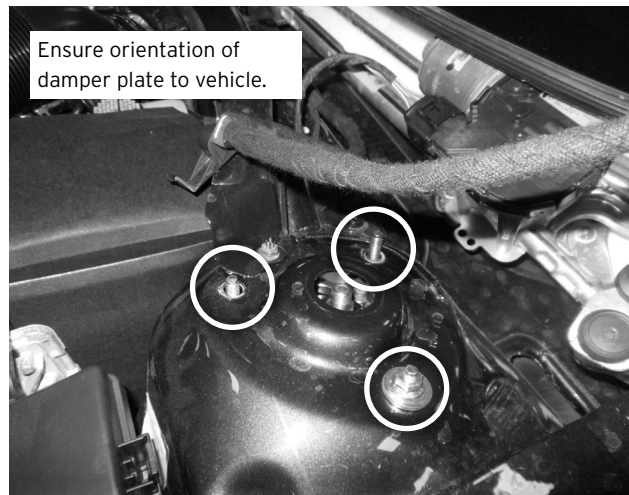

Fig. 28

- Lift the hub assembly, sliding over the strut lower mount with the locating pin between the clamp area (Fig. 29). With the lower mount fully seated (Fig. 30), install the lower clamp bolt (Fig. 31). Torque to 70Nm (52 lb.-ft.).

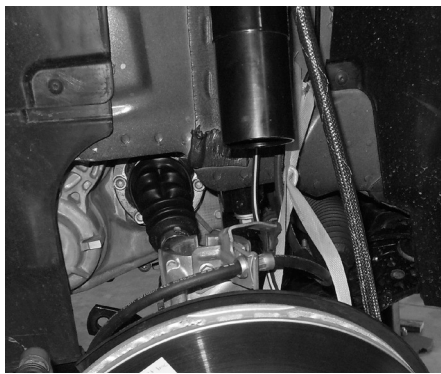

Fig. 29



Fig. 30



Fig. 31

- Attach supplied end link to the stabilizer bar, and torque to 65Nm (48 lb.-ft.) (Fig. 32).

5. Attach the end link stud to the end link tab on the strut (Fig. 32). Torque to 65Nm (48 lb.-ft.).



Fig. 32

SECTION 4. ROUTE THE AIR LINES



WARNING

AFTER INSTALLATION, ENSURE ALL ORIGINAL EQUIPMENT VEHICLE SAFETY FEATURES ARE PROPERLY CALIBRATED BY A QUALIFIED TECHNICIAN. CHANGING VEHICLE HEIGHT MAY AFFECT FUNCTIONING OF SAFETY SENSORS AND CAMERAS.

1. Fully compress the suspension using a jack. With the suspension compressed, review the best routing for the air line that is clear of all suspension and steering components.
2. Routing should allow for the suspension to extend and steer without kinking, pulling the line tight, or rubbing on other components. Following the brake line routing is often a good place to start. Check clearances to all other components.



PLEASE READ - IMPORTANT INSTALLATION INFORMATION

Please refer to your control system installation guide for more details on air line routing and to ensure the installation of your air suspension system is complete.

Before Operating

SET THE RIDE HEIGHT

1. Refer to the User Guide supplied with this kit to set up the suspension.

Torque Specifications		
Location	Nm	lb.-ft.
Camber plate to chassis	27	20
Lower strut clamp bolt	70	52
Stabilizer end link to bar	65	48
Stabilizer end link to strut	65	48
Camber adjustment bolt	15	11
Ball joint to control arm	60	44
Axle bolt (12 point without ribs)	200	148
Axle bolt (12 point with ribs)	70 + 90 degrees	52 + 90 degrees
Forward control arm to sub-frame bushing bolt	70 + 180 degrees	52 + 180 degrees
Wheel studs	120	89
Braided air line threads	1 3/4 turns beyond hand-tight	

2. Upon successful completion of the installation, follow these pressure requirements for the air springs.

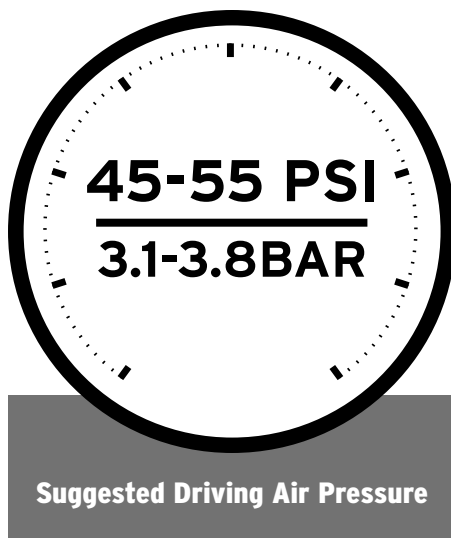

CAUTION

FAILURE TO MAINTAIN ADEQUATE MINIMUM PRESSURE (OR PRESSURE PROPORTIONAL TO LOAD) MAY RESULT IN EXCESSIVE BOTTOMING OUT AND **WILL VOID THE WARRANTY.**

CHECK FOR BINDING



CAUTION

MAKE SURE THE FRONT WHEELS ARE STRAIGHT WHEN DEFLATING AND REINFLATING AIR SPRINGS.

1. Inflate and deflate the system (do not exceed 8.6BAR [125 PSI]) to check for clearance or binding issues. With the air springs deflated, check clearances on everything so as not to pinch brake lines, vent tubes, etc. Clear lines if necessary.
2. Inflate the air springs to 5.2-6.2BAR (75-90 PSI) and check all connections for leaks.

INSTALLATION CHECKLIST

- Clearance** – Inflate the air springs to 5.2-6.2BAR (75-90 PSI) and make sure there is at least 13mm (1/2") clearance from anything that might rub against the air spring. This should be checked with the air spring fully inflated and fully deflated.
- Leak** – Inflate the air springs to 5.2-6.2BAR (75-90 PSI) and check all connections for leaks. All leaks must be eliminated before the vehicle is road-tested.
- Heat** – Be sure there is sufficient clearance from heat sources, at least 152mm (6") from air springs and air lines. If a heat shield was included in the kit, install it. If there is no heat shield, but one is required, call Air Lift customer service at **(800) 248-0892**.
- Fastener** – Recheck all bolts for proper torque.
- Road** – Inflate the air springs to recommended driving pressures (see previous page). Drive the vehicle 16km (10 miles) and recheck for clearance, loose fasteners, and air leaks.
- Operating instructions** – If professionally installed, the installer should review the operating instructions with the owner. Be sure to provide the owner with all paperwork that came with the kit.

DAMPING ADJUSTMENT

1. The dampers in this kit have 32 settings, or “clicks,” of adjustable compression and rebound damping characteristics. Damping is changed through the damper rod using the supplied adjuster (example shown here) or a 3mm hex key (not included).

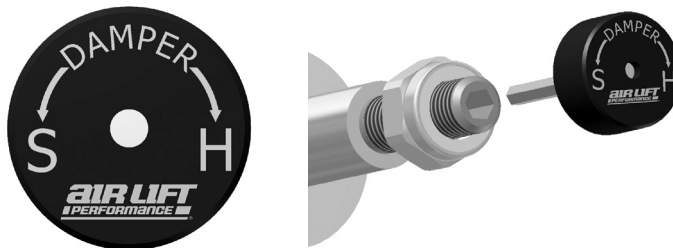

2. Turn the adjuster clockwise (H), and the damping settings are hardened, reducing oscillations and body motion. Turn the adjuster counterclockwise (S), and the damping is softened.
3. Each damper will need to be set after installation and your initial drive, as they are not pre-set. It may take multiple adjustments to dial in your ideal ride. A good starting point is in the middle at 16 clicks from full soft, then drive the vehicle and make adjustments either softer or stiffer.

For more information, refer to the user guide.

Limited Warranty and Return Policy

Air Lift Company provides a limited warranty* to the original purchaser of Air Lift Performance Air Suspension kits from the date of original purchase, that the products will be free from defects in workmanship and materials when used on cars and trucks as specified by Air Lift Company and under normal operating conditions, subject to the requirements and exclusions set forth in the full Limited Warranty and Return Policy.

* Full Limited Warranty and Return Policy are available at www.airliftperformance.com/warranty and are subject to change.

WARRANTY REGISTRATION & CLAIMS

- To register your warranty, please visit <https://www.airliftperformance.com/support/warranty-registration/>
- To submit a warranty claim, please visit <https://www.airliftperformance.com/support/submit-warranty-claim/>

Thank you for purchasing Air Lift Performance products!

Need Help?

Contact Air Lift Company Customer Service at (800) 248-0892 or +1 (517) 322-2144 for calls from outside the U.S. and Canada.



Connect by searching for **Air Lift Performance** #LifeonAir

AIR LIFT
PERFORMANCE

2727 Snow Road Lansing, MI 48917 or P.O. Box 80167 Lansing, MI 48908-0167
Toll Free (800) 248-0892 • Local (517) 322-2144 • Fax (517) 322-0240
www.airliftperformance.com



MADE IN USA
WITH GLOBAL
COMPONENTS

Air Lift Company reserves the right to make changes and improvements to its products and publications at any time. For the latest version of this manual, contact Air Lift Company at (800) 248-0892 or visit airliftperformance.com.