

# Fuel Pressure Regulator DWR1000 (6-1000-FRB, 6-1000-FRT)



The *DWR1000* regulator is engineered to support EFI engines producing between 250HP and 2000HP. This regulator features the optimum balance of fitment versatility, premium construction, and precision performance. It is available in your choice of black or titanium finish.

- Precision performance and versatility of up to 1,000LPH
- Supports up to 2000hp on Ethanol
- Supports up to 2500hp on Gasoline
- -8AN ORB inlets, -6AN ORB outlet
- Compatible with all fuels including methanol and ethanol
- 2 psi per turn precision ball bearing adjustment
- Multi-directional bracket for Installation flexibility
- 3 Year Comprehensive Warranty

## Dimensions

## Specifications

<b>Weight</b>	8.6 oz (244g)
<b>External Materials</b>	Anodized T6061
<b>Hardware/Brackets</b>	300 Stainless Steel
<b>Tension Spring</b>	Stainless Spring Steel
<b>Diaphragm</b>	35mm Fiber-Nitrile
<b>Pressure Range</b>	30-120psi
<b>Flow Rating</b>	1000 LPH
<b>HP Rating</b>	2000 HP
<b>Gauge Port Fitting</b>	1/8" NPT*
<b>Inlet Ports</b>	Quad -8AN ORB
<b>Outlet Ports</b>	Single -6AN ORB
<b>Vac/Boost Ref Port</b>	1/16" NPT
<b>Vac/Boost Ref Barb</b>	3/16"

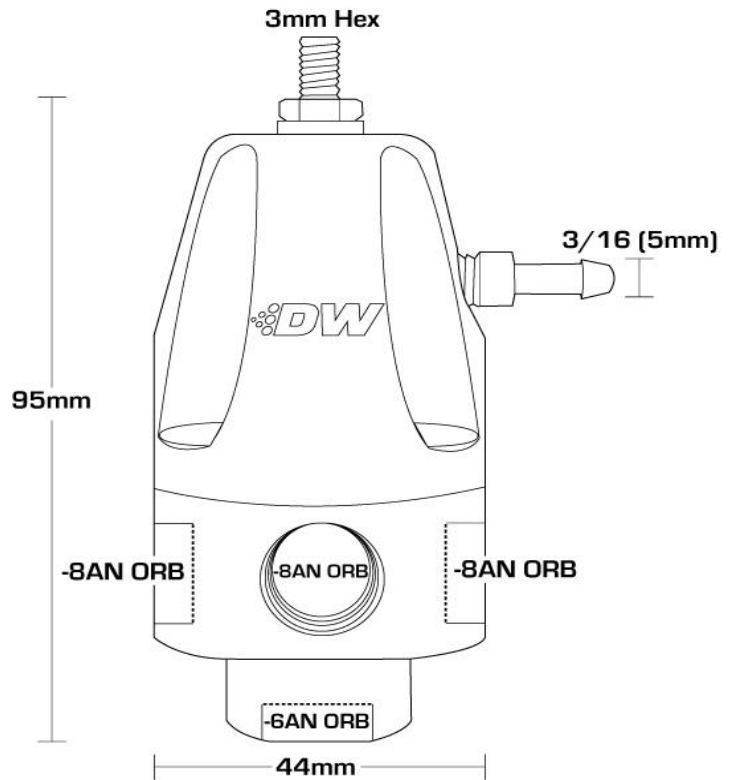

THIS PRODUCT MAY BE USED SOLELY ON VEHICLES USED IN SANCTIONED COMPETITION WHICH MAY NEVER BE USED UPON A PUBLIC ROAD OR HIGHWAY, UNLESS PERMITTED BY SPECIFIC REGULATORY EXEMPTION