



DO NOT USE IMPACT TOOLS

PARTS INCLUDED	QTY
Step Rail	2
Rocker Panel mounting Brackets	4

HARDWARE DESCRIPTION	QTY.
HWKT-00032X	
M8 – 1.25 HX FLANGED NUT	12
3/8" x 3/4" carriage bolts	8
3/8" Flanged nuts	8

Step 1. Identify the Driver side step.

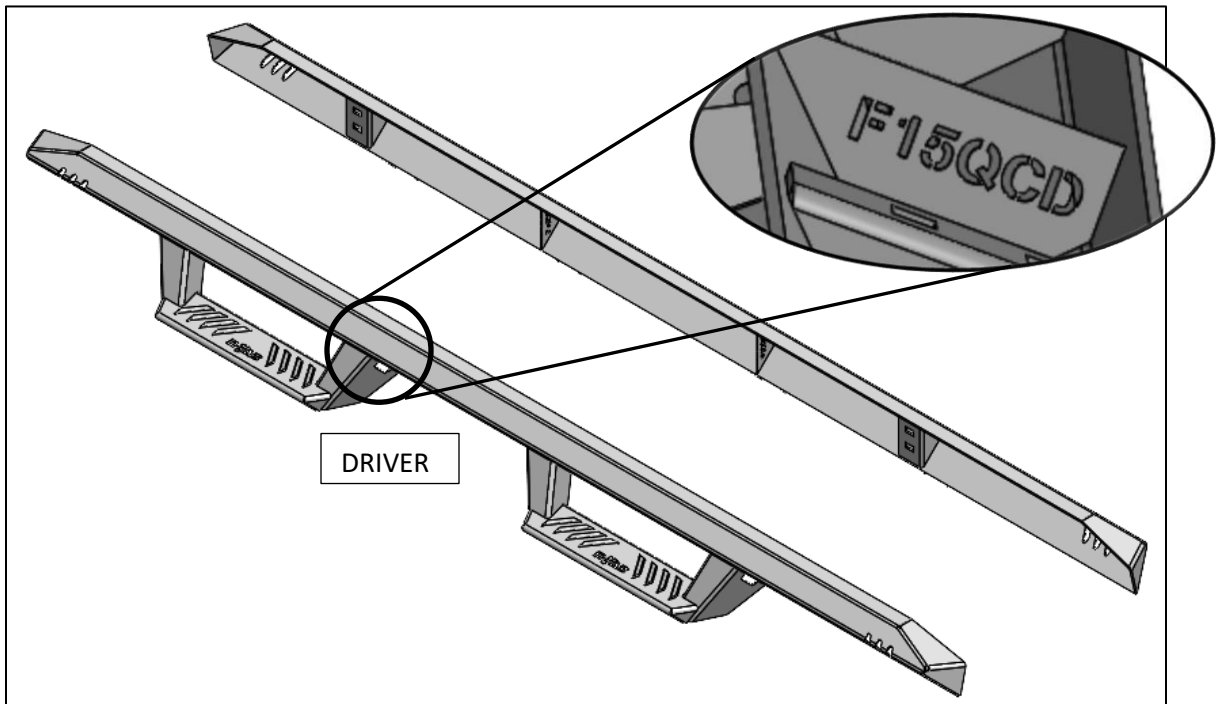

Step 2: Install three rocker panel brackets to the attachments points located on the backside of the channel using the supplied 3/8" x 3/4" carriage bolts and 3/8" flanged nuts. Leave finger tight for now.

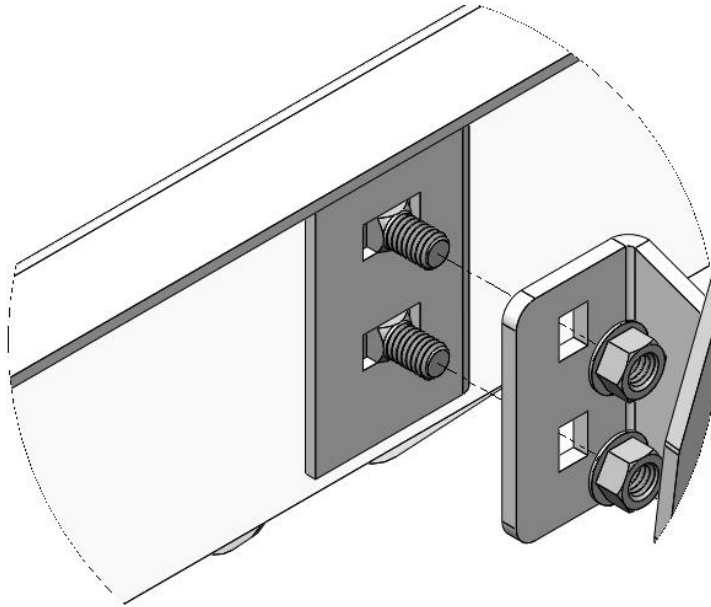

Step 3: Starting with the Driver Side. Remove all 8mm flange nuts from the 8mm factory threaded studs to remove the OE running boards.

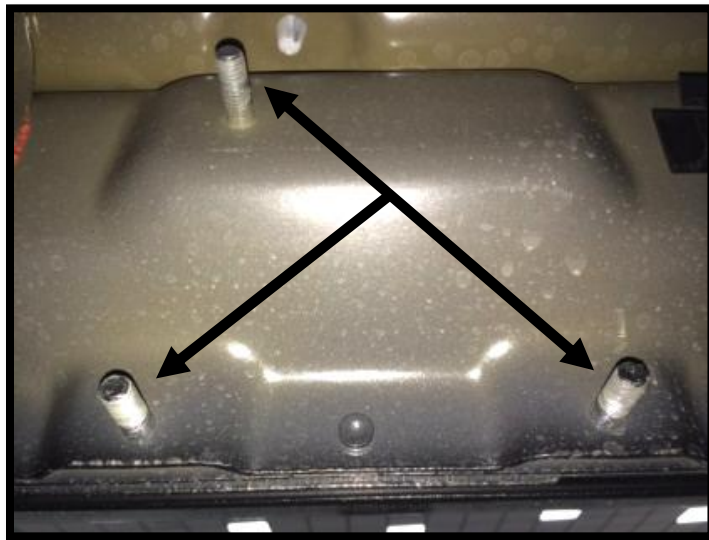

Step 4: Next, carefully raise the step assembly into position and align the three brackets with the nine 8mm OE threaded studs.

Step 5: Using the supplied 8mm flanged nuts, fasten all nine mounting positions. Leave loose at this time.



Step 6: Next, adjust the step assembly up/down and front/back to level out the step rail with body panel and then tighten step to brackets at 20 ft. /lbs.



Step 7: Adjust the step rail to where you have approximately ¼" gap between the body of the vehicle and the top of the rail.



Step 8: After final adjustment, tighten all rocker panel brackets to 30 ft./lbs.

Step 9: Re-peat steps 3-8 for passenger side.