

IMPORTANT

READ BEFORE YOU BEGIN INSTALLATION

IT IS CRITICAL FOR YOUR SAFETY THAT YOU CAREFULLY READ AND FOLLOW THE SAFETY CAUTIONS AND INSTALLATION INSTRUCTIONS BOTH PRIOR TO AND DURING INSTALLATION.

USER SAFETY CAUTION

During installation, be mindful of the potential for sharp edges on the product or vehicle. Taking proper safety precautions helps ensure a safe and smooth installation process.

Always wear protective gloves and handle components with care to reduce the risk of injury.



TEMPERATURE SURFACE CAUTION

During high temperatures or extended sun exposure, surfaces of this product may become hot to the touch, posing a risk of burns or injury. Use caution when handling the product in hot weather and allow time for it to cool before contact.

Always check surface temperature before use to ensure safe handling conditions.



FASTENER TORQUE CAUTION

All fasteners must be tightened to the specified torque values provided in the installation instructions to ensure proper fit and safe operation of the tonneau cover. Under- or over-tightening can lead to product failure, potential damage to your vehicle, injury, or safety hazards while driving.

Always use a calibrated torque wrench and follow the specifications in the installation instructions.

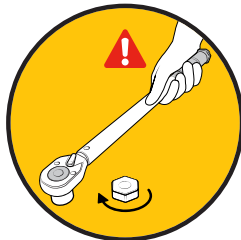

PINCH POINT SAFETY CAUTION

This tonneau cover may create pinch points when closing or operating near solid surfaces such as the truck bed rails or tailgate. To prevent injury, keep hands, fingers, and other body parts clear of moving parts during operation.

Always operate the cover slowly and with caution to ensure safe and proper use.



IMPORTANT

READ BEFORE YOU BEGIN INSTALLATION

IT IS CRITICAL FOR YOUR SAFETY THAT YOU CAREFULLY READ AND FOLLOW THE SAFETY CAUTIONS AND INSTALLATION INSTRUCTIONS BOTH PRIOR TO AND DURING INSTALLATION.

ENTRAPMENT SAFETY WARNING

This tonneau cover does not feature a manual release mechanism from inside the truck bed. To prevent the risk of entrapment, never allow anyone to be inside the bed of the truck when the cover is closed.

Always ensure the area is clear before closing the cover, and keep the cover securely latched when not in use to avoid accidental closure.

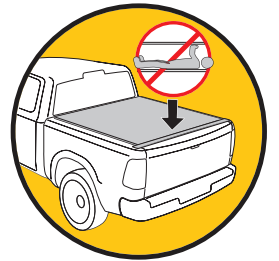

CARGO TRANSPORT WARNING

Do not attempt to close the tonneau cover over cargo that is taller than the depth of the truck bed.

Never force the cover to close improperly.

Forcing the cover can:

- Prevent the cover from lying flat and latching securely.
- Damage the cover's hinge and cause the cover to kink.
- Damage the rear tail panel and cause it to become detached.

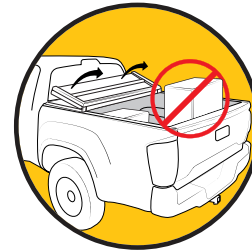

INSTALLATION SHEET

Any damaged or missing parts?

Parts will be shipped to you directly.

Call 800-877-2588, Mon - Fri, 8:30 a.m. - 6:00 p.m. EST

ALL

B 	C 	D
--------------	--------------	--------------

TACOMA

E 	F 	G
--------------	--------------	--------------

COMES IN SEPARATE PIECES (E, F, G)

TUNDRA & TITAN

H 	I
--------------	--------------

COMES PRE-ASSEMBLED (H, I & D)

NOTE: It is important that all areas where the bed cover mounts are clean and free of debris prior to installing.

PARTS INCLUDED IN YOUR KIT

- A** Cover assembly (All)
- B** 2x Cab slide blocks (All)
- C** 4x Cab clamp brackets (All)
- D** 4x Cab Torx screws (All)
- E** 4x Torx screws (All)
- F** 2x Slide blocks (Tacoma)
- G** 2x Striker brackets (Tacoma)
- H** 2x Slide blocks (Tundra & Titan)
- I** 2x Striker brackets (Tundra & Titan)

TOOLS PROVIDED

- Torx wrench - T-20
- 2x Torx wrench - T-27
- Hex wrench - 2.5MM

TOOLS REQUIRED FOR TACOMA

- Wrench or socket - 13mm



1 Place the folded, cover (A) on the cab end of the truck bed. Make sure the cover is square with the truck bed and the bulkhead seal sits on the truck bed bulkhead.

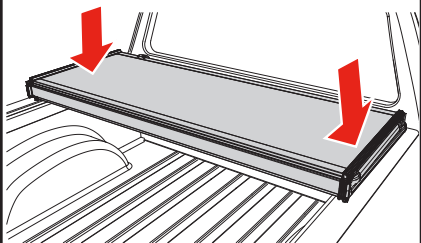

2 Unfold the bed cover (A) fully and adjust its position over the truck bed for the proper front (cab) and rear (tailgate) alignment. When positioned front and back, the tailgate seal should contact the tailgate with the first two fins.

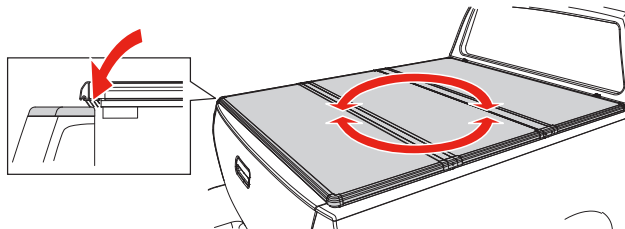

3 Carefully refold the bed cover (A) without shifting its position on the truck bed.

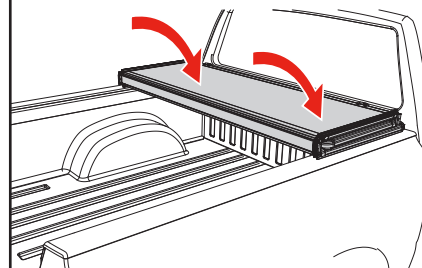

4 If there are cargo rail end caps remove the rear (tailgate) end. Remove any tie-downs. Do this for both sides of the bed.

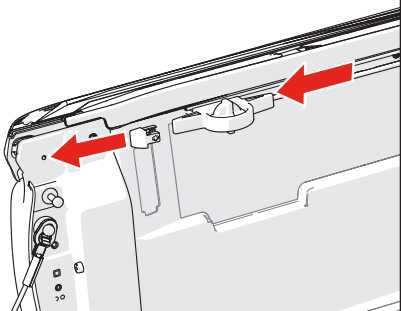

5 Install the cab slide block (B) into the rear (tailgate) end of the cargo rail. Position near the cab. Align the cab clamp bracket (C) with the cab clamp of the bed cover. Use the Torx screws (D) to mount the cab clamp bracket (C) to the cab slide block (B). Tighten the screws with the T-27 Torx tool. Do this for both sides of the truck bed.

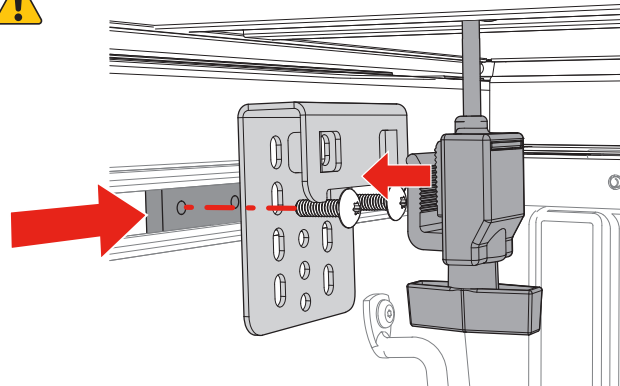

6 Hook the cab clamp under the cab clamp bracket (C) and tighten the T-handle until it contacts the bracket (C), then tighten two more turns. Do this for both sides of the truck bed.

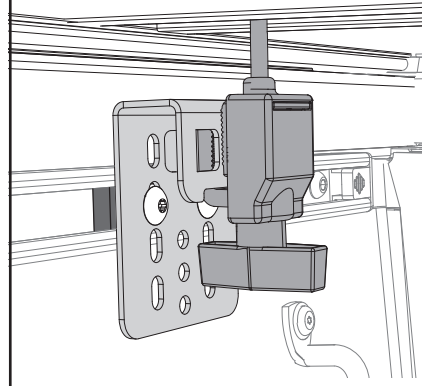

7 To install the tether first unscrew the knob from the slide block and separate the block, knob and washer.

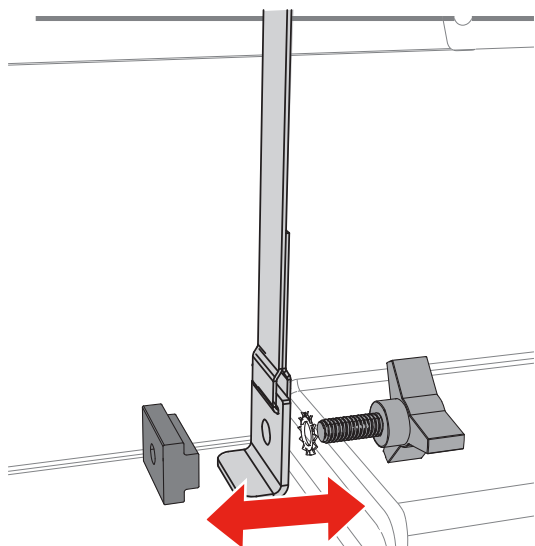

8 Install the slide block in the back of the cargo rail. Reassemble the tether by threading the knob through the washer and into the slide block. Install the tether on both sides of the bed.

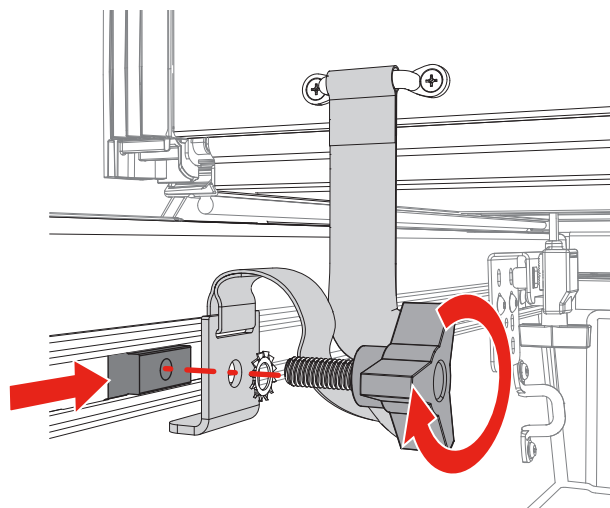

9 Reinstall any tie-downs back into the cargo rail.

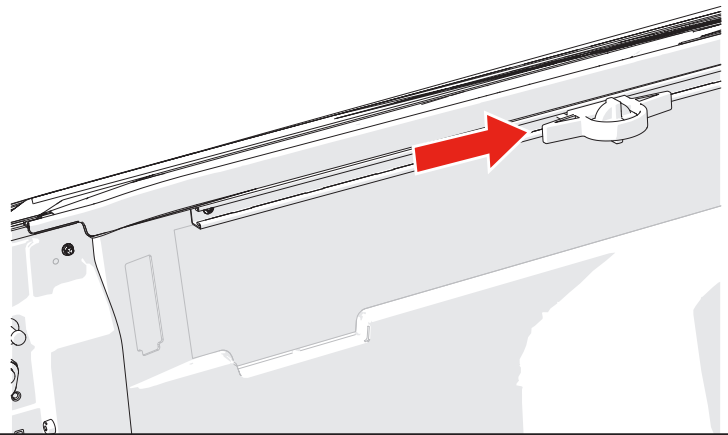

10 With the tailgate open and the front (cab) clamps secure, completely close the bed cover.

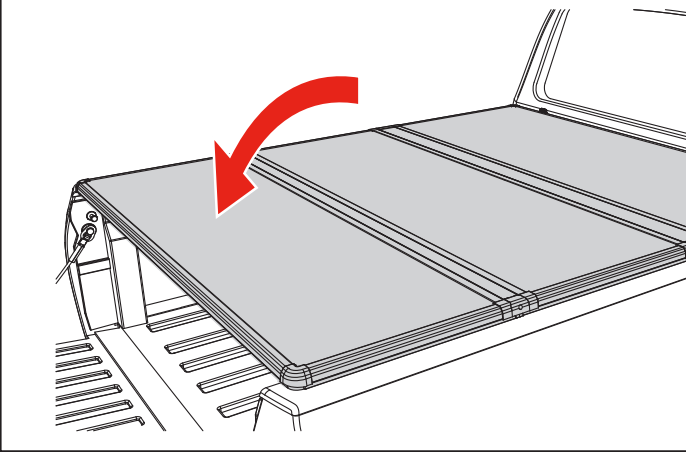

11A TACOMA MODELS ONLY

Remove the factory bolt as shown, keep them for reuse.

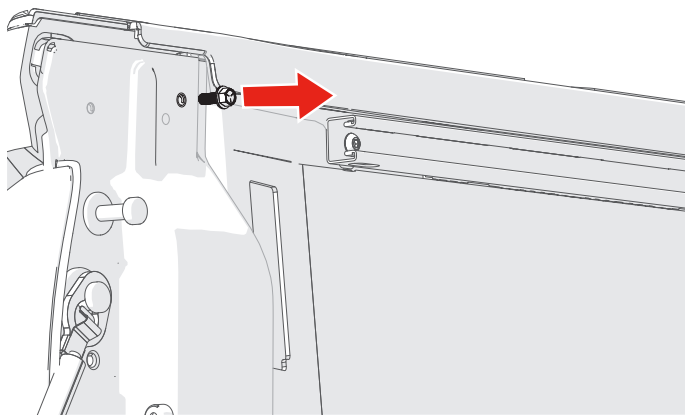

Install the Tacoma rear (tailgate) striker bracket (G) using the factory bolt reinstalled into the same hole from where it was removed and the Torx screw (E) threaded into the slide block (F).

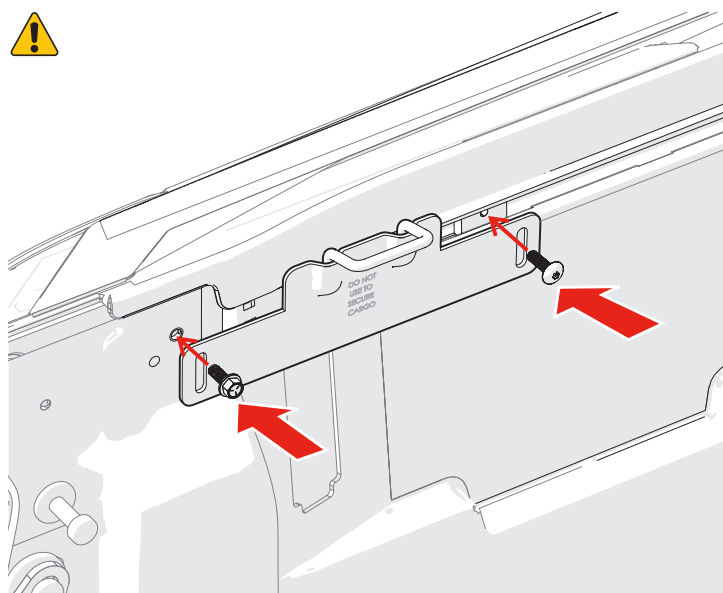

Install the Tacoma short slide block (F) for the rear (tailgate) striker bracket (G) into the end of the cargo rail.

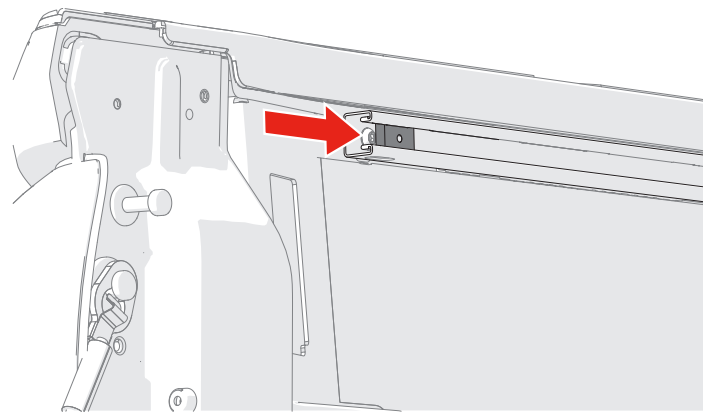

Adjust the rear (tailgate) striker bracket (G) so that it aligns squarely with the cover latch. Push down on cover when tightening the bolt and screws (E) so that the rear (tailgate) striker bracket (G) pulls the cover down tightly to the truck bed cap. Do this for both sides of the truck bed. Hand tighten for further adjustment later.

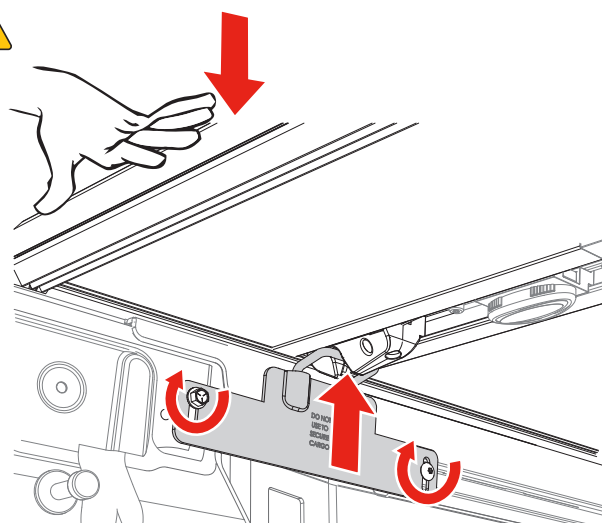

11B TUNDRA & TITAN MODELS ONLY

Disassemble the rear (tailgate) striker bracket (I) by removing the Torx screws (E). Then install the slide block (H) into the tail end of the cargo rail. Align the rear (tailgate) striker bracket (I) with the bed cover latch. Attach the striker bracket (I) to the slide block (H) using the Torx screws (E). Hand tighten for further adjustment later.

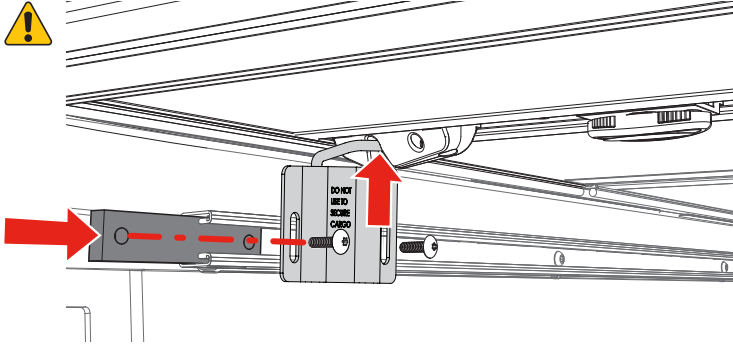

Adjust the rear (tailgate) striker bracket (I) so that it aligns squarely with the cover latch. Push down on cover when tightening the Torx screws (E) so that the rear (tailgate) striker bracket (I) pulls the cover down tightly to the truck bed cap. Do this for both sides of the truck bed. Hand tighten for further adjustment later.

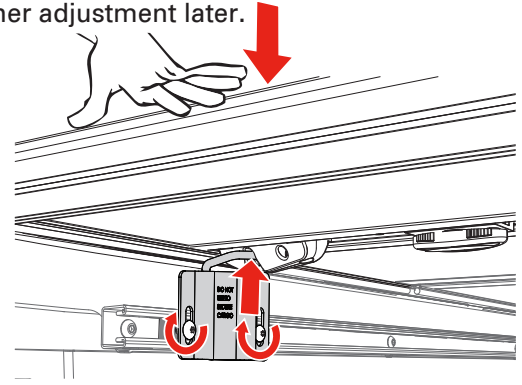

12 Adjustments and tightening of the latch assembly is required.

The bed cover latch assembly and rotary knob comes from the factory only partially tightened to allow for installation adjustments. **Only use the hand tools provided, do not use power tools.**

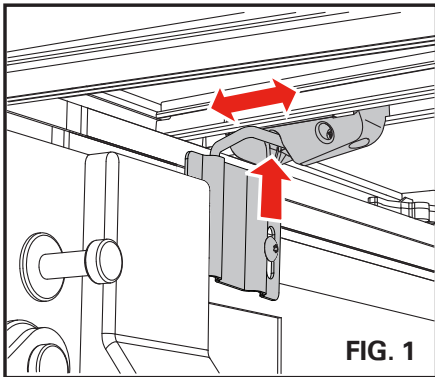

Lower the rear of the bed cover and loosen the screws on both latch assemblies and the rotary knob. Rotate the knob to locate the screws. Adjust the position of each latch so that they engage with the striker brackets, (Fig. 1). With the latches adjusted, from underneath the cover, use the provided T-20 Torx wrench to tighten the two screws, (Fig. 2) so the latch does not move in the channel. Repeat on the other side.

The cables come routed through the barrel clamps of the rotary knob. Adjust the position of the rotary knob so that the cable from the driver side latch can be inserted through the barrel clamp leaving 3/4" - 1" of cable extending through the barrel clamp without turning the knob, for future adjustments (Fig. 3).

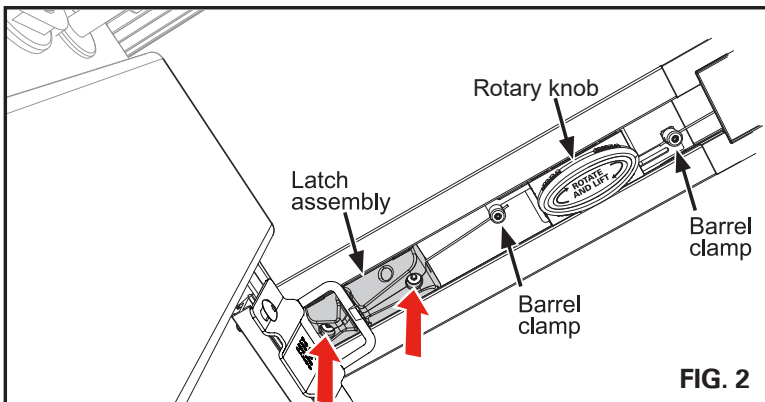

Rotate the rotary knob until you see the flat head screws. Tighten the two screws using the provided Torx T-20 wrench, (Fig. 3). So the knob does not move in the channel. Repeat on the other side.

Next, tighten the barrel clamp set screws, (Fig. 4) with the provided 2.5mm hex key to secure the latch cables. Rotate the rotary knob, (Fig. 4) to verify that the latches disengage from the striker brackets.

Close the cover, then double-check that it is secure and tight to the truck bed by gently lifting the corners to ensure the mechanisms are engaged.

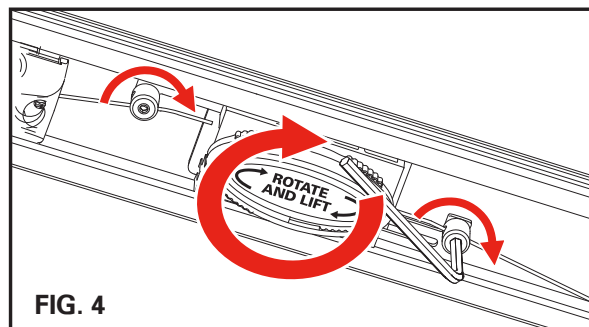
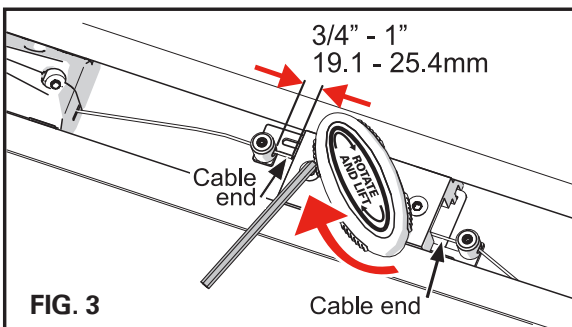

13 To make the final adjustment, loosen the striker bracket screws. Then move the bracket (G, I) down by firmly pulling the cover (A) to the truck rail and tailgate. Make sure that both sides match, then retighten the screws. **NOTE:** Replace, if necessary, any cargo rail end caps.

! TUNDRA & TITAN STRIKER BRACKET

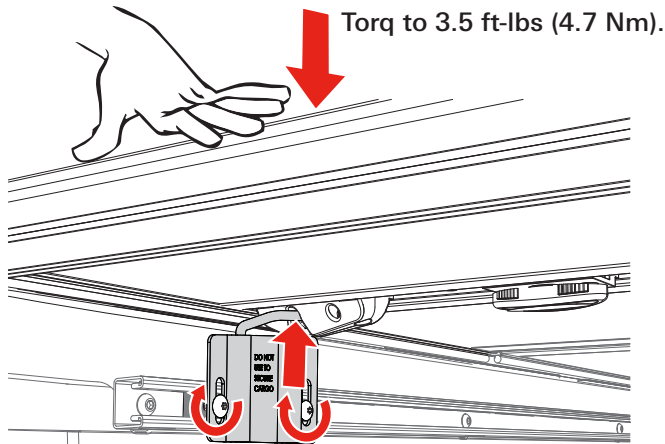

TACOMA STRIKER BRACKET

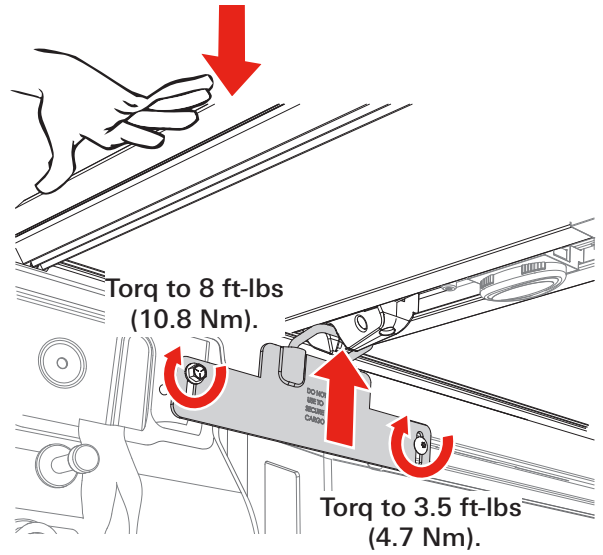

Opening the cover

Open the cover by twisting the rotary knob and lifting the cover.

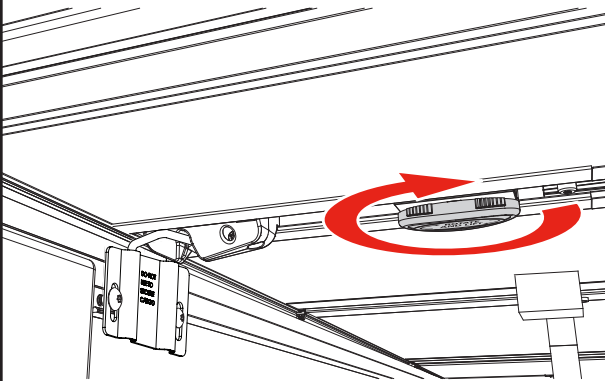

Securing the cover

To drive with the cover open, fold the cover forward to the cab and fasten **BOTH** straps in the middle section to the front rail. Check that the straps are tight, and pull the strap end if too loose.

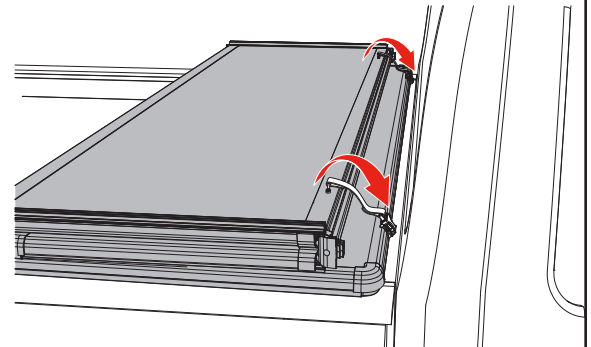
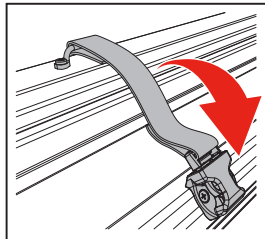

! IMPORTANT

Re-tighten the front/cab clamps and tethers after the first week of driving the vehicle. Also periodically check the clamps and tethers to ensure they are secure.

Closed/Extended Position – Bed cover must be completely secured by all four (4) clamps.

Open/Folded Position – Bed cover must be completely folded up (all panels) and secured at the cab with the provided buckles straps and with both tethers attached.

Do NOT drive with the bed cover in a partially open position.

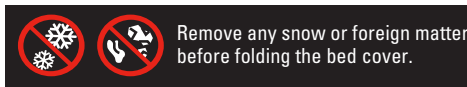
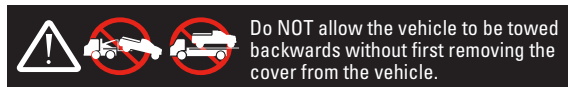
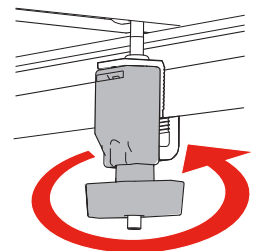

REPLACEMENT PARTS

Replacement parts can be ordered online at extang.com/replacement-parts or you can contact our Customer Service Department for assistance. When ordering, xxx represents the 3 digit suffix, as referenced on the sales receipt or vehicle application list.

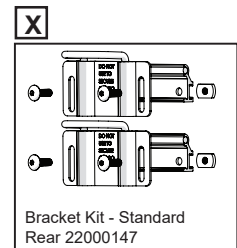
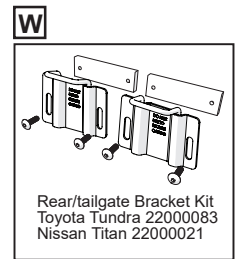
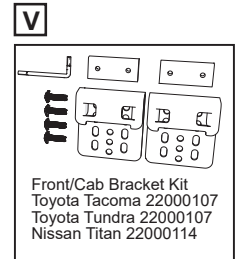
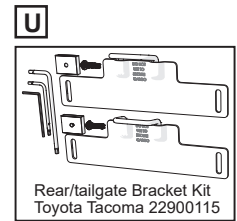
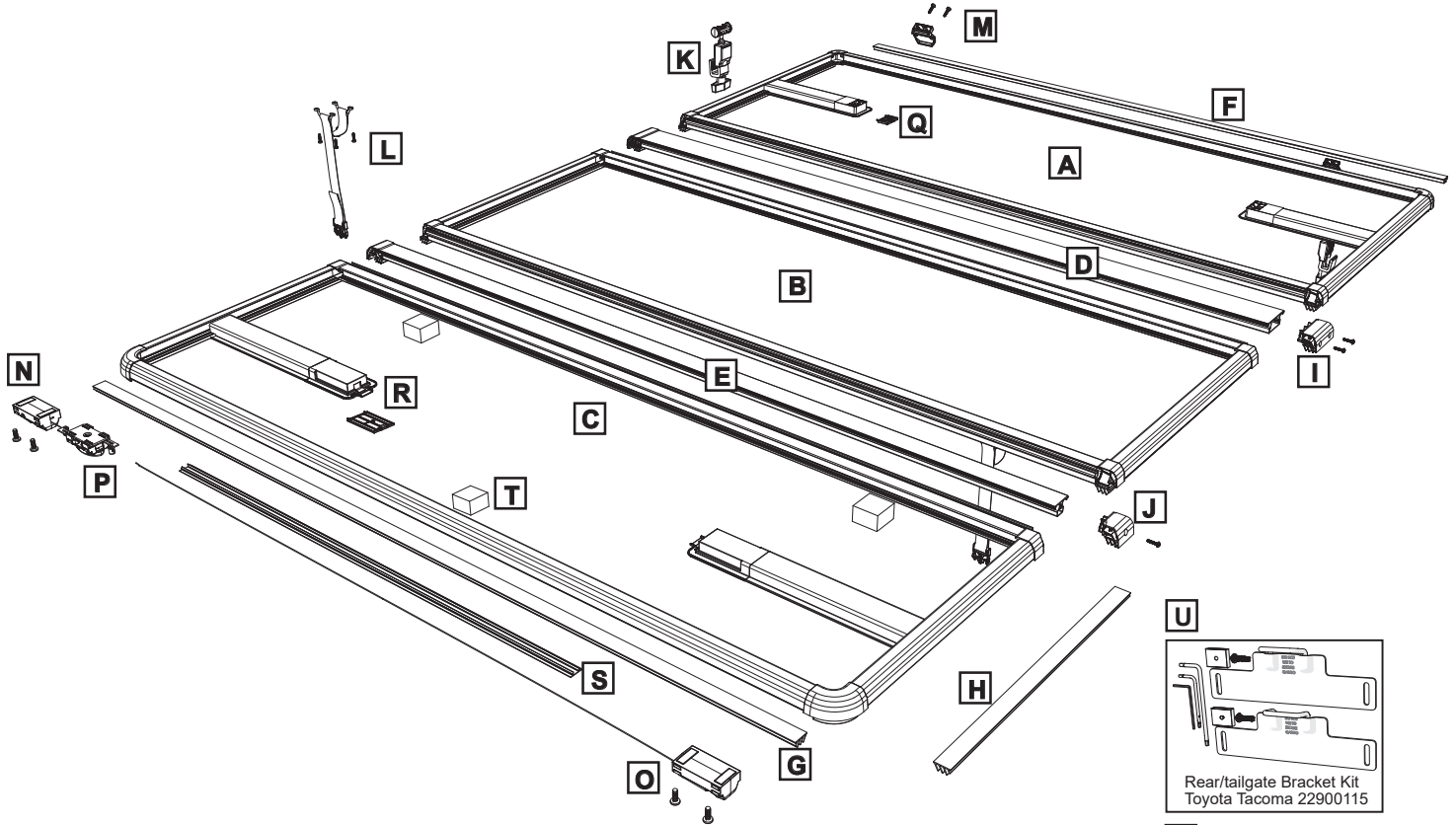

Call Out	Title	Part Number	Description	Qty
A	Cab Panel	88xxx-60	Cab panel assembly	1
B	Mid Panel	88xxx-61	Mid panel assembly	1
C	Tail Panel	88xxx-62	Tail panel assembly	1
D	Cab Hinge	88xxx-63	Cab hinge assembly	1
E	Tail Hinge	88xxx-64	Tail hinge assembly	1
F	Cab Seal	32002112	Single length seal (68"), hollow seal, cut to fit	1
G	Tailgate Seal	32563200	Single length seal, (68"), 4-fin, cut to fit	1
H	Side Seal	32000685	Single length (68") Side Seal, cut to fit	1
I	Cab Hinge Cap Kit	31830010	Cab hinge cap & fasteners	1
J	Tail Hinge Cap Kit	31830020	Tail hinge cap & fasteners	1
K	Front (Cab) Clamp	*	Front clamp assembly*	1
L	Tie Down Kit	31831010	Male buckle Strap & fasteners	1
M	Cab Buckle Kit	31830002	Female buckle & fasteners	1
N	Latch Assembly, Driver	28900100	Autolatch assembly for the driver side	1
O	Latch Assembly, Passenger	28900101	Autolatch assembly for the passenger side	1
P	Rotary Release Assembly	28900102	Rotary assembly	1
Q	Latch Pocket Cover, Cab	35830102	Plastic cover for the latch pocket on the cab panel	1
R	Latch Pocket Cover, Tail	35880002	Plastic cover for the latch pocket on the cab panel	1
S	Cable Cover	35880003	Snap-in cable cover	1
T	Spacer Pad	32622500	Foam adhesive backed pad	1
U	Rear/Tailgate Bracket Kit	22900115	Toyota Tacoma	1
V	Front/Cab Bracket Kit	22000107	Toyota Tacoma and Tundra	1
	Front/Cab Bracket Kit	22000114	Nissan Titan	1
W	Rear/Tailgate Bracket Kit	22000083	Toyota Tundra	1
	Rear/Tailgate Bracket Kit	22000021	Nissan Titan	1
X	Striker Bracket Kit	22000147	Standard Rear/Tailgate Bracket Kit	1

* Specify, year, make, model, long or short bed, driver or passenger side.

LIMITED WARRANTY

WARRANTY COVERAGE

This truck bed cover is warranted against defects in materials or workmanship as follows. This warranty is void if the product has been damaged in an accident, or due to neglect, unforeseeable use, improper installation, improper servicing, or other cause not arising out of defects in material or workmanship.

The truck bed cover carries a limited warranty for five (5) years from the original date of purchase, subject to the terms below.

WARRANTY IS NOT TRANSFERABLE

The warranty is to the initial owner purchasing the truck bed cover and it is not transferrable to a subsequent end user. Proof of purchase may be required to enforce these warranty rights.

WARRANTY CONDITIONS

Failure to follow these care and use instructions will void the warranty.

- Clean with mild automotive soap and water only.
- Cover must be secured at all points when vehicle is in motion. When not fully extended, cover must be completely folded up and secured at the cab with the provided buckle straps and tethers attached. Do NOT drive with the bed cover in a partially open position.
- Check all clamps and retention mechanisms for tightness after a week of driving following installation (or re-installation) of the cover and periodically thereafter.
- Before opening, cover must be free of all foreign materials including snow and ice.
- Do NOT tow your vehicle from the rear with the cover on your vehicle. If towing from the rear is required, the cover MUST be removed from the vehicle and properly stored.

WARRANTY PERFORMANCE

If all warranty conditions are met, a defective truck bed cover or hardware component will either be repaired or replaced (at our option). We reserve the right, for any warranty, to substitute a newer model or bed cover having similar form and function, to offer a warranty discount on an entire replacement system, and/or provide remedies other than those mentioned in this document.

WARRANTY PROCESS

A Return Authorization number must be obtained from our Customer Service Department prior to returning any product. We may require the original item to be returned postage prepaid for final determination. Shipping charges will apply for any repair or replacement. Other than postage or shipping charges, no charge will be made for repair or replacement under this warranty.

This warranty gives you specific legal rights. As an owner, you may also have additional rights and remedies under the laws of your state.

WARRANTY REGISTRATION

Warranty registration must be on file and/or proof of original purchase (detailed and dated receipt) required for warranty to be effective.

Register online at <https://realtruck.com/extang-warranty>

**REGISTER
YOUR
WARRANTY
ONLINE**



SOMETHING DAMAGED? MISSING PARTS?

CALL US FIRST
800-877-2588

WE CAN HELP YOU QUICKLY AND EASILY OVER THE PHONE

Experienced Customer Service staff are available
to answer all your truck bed cover questions

CUSTOMER SERVICE HOURS

8:30 a.m. TO 6:00 p.m. EST, MONDAY - FRIDAY

Truck bed cover model: _____

Purchase date: _____

Lot code: _____

Lot code can be found on the underside of cover.