

# Ranger 2024+ QUICK START INSTALLATION SHEET

**Any damaged or missing parts?**

Parts will be shipped to you directly.

Call 800-206-4070 Mon - Fri, 8:00 a.m. - 5:00 p.m. CST  
or email [retrax@retrax.com](mailto:retrax@retrax.com)

**PLEASE READ INSTRUCTIONS CAREFULLY  
BEFORE STARTING THE INSTALLATION.**

- 1** Physically install the Retrax EQ cover on the truck and make all necessary wired connections.  
*Refer to the next page for full EQ installation instructions.*

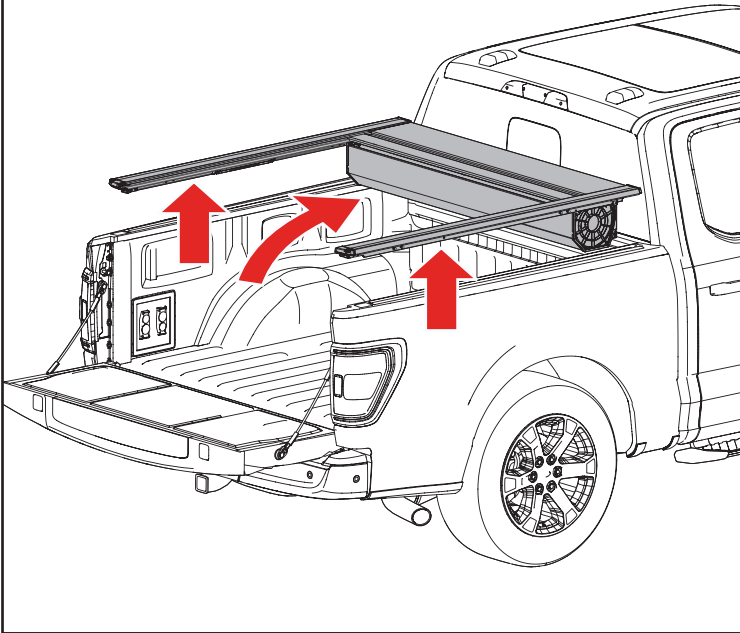

- 2** Physically install the cabin module inside the truck.

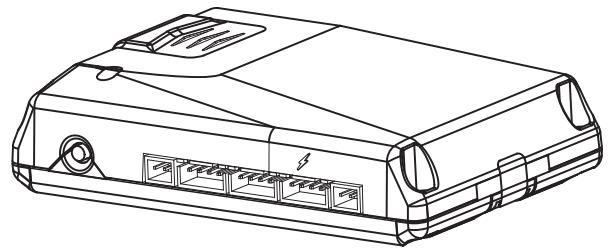

- 3** Open the installer app and follow prompts to configure the **CABIN** module.



- 4** In the installer app follow the prompts to configure the **COVER** module.

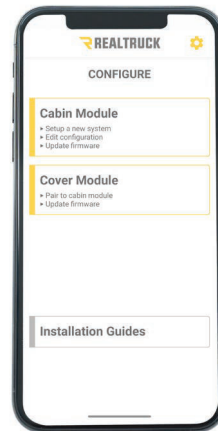

- 5** Pair accessory controls such as keypad and phone (optional). *Refer to the instructions shipped with accessories.*

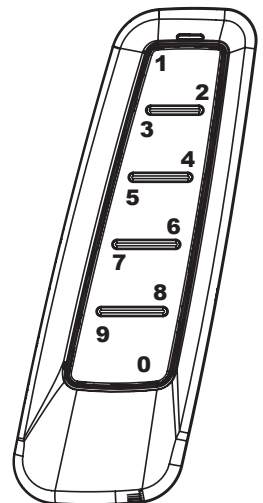

Any damaged or missing parts?

Parts will be shipped to you directly.

Call 800-206-4070 Mon - Fri, 8:00 a.m. - 5:00 p.m. CST  
or email [retrax@retrax.com](mailto:retrax@retrax.com)

**IMPORTANT:** You will need to download the **RealTruck EQ Installer** and **RealTruck EQ** user apps to complete this installation.

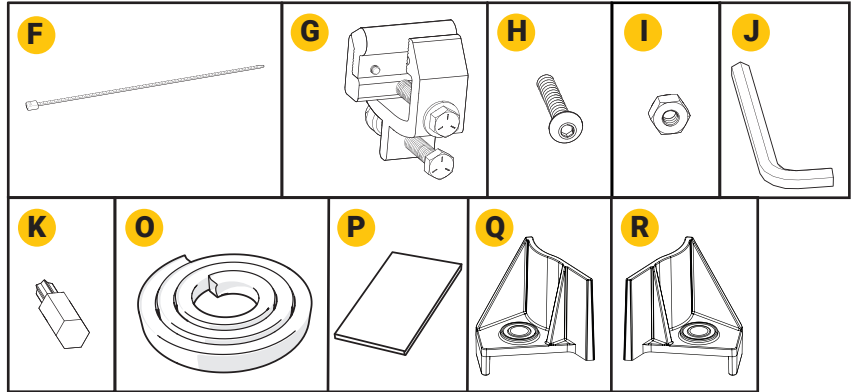
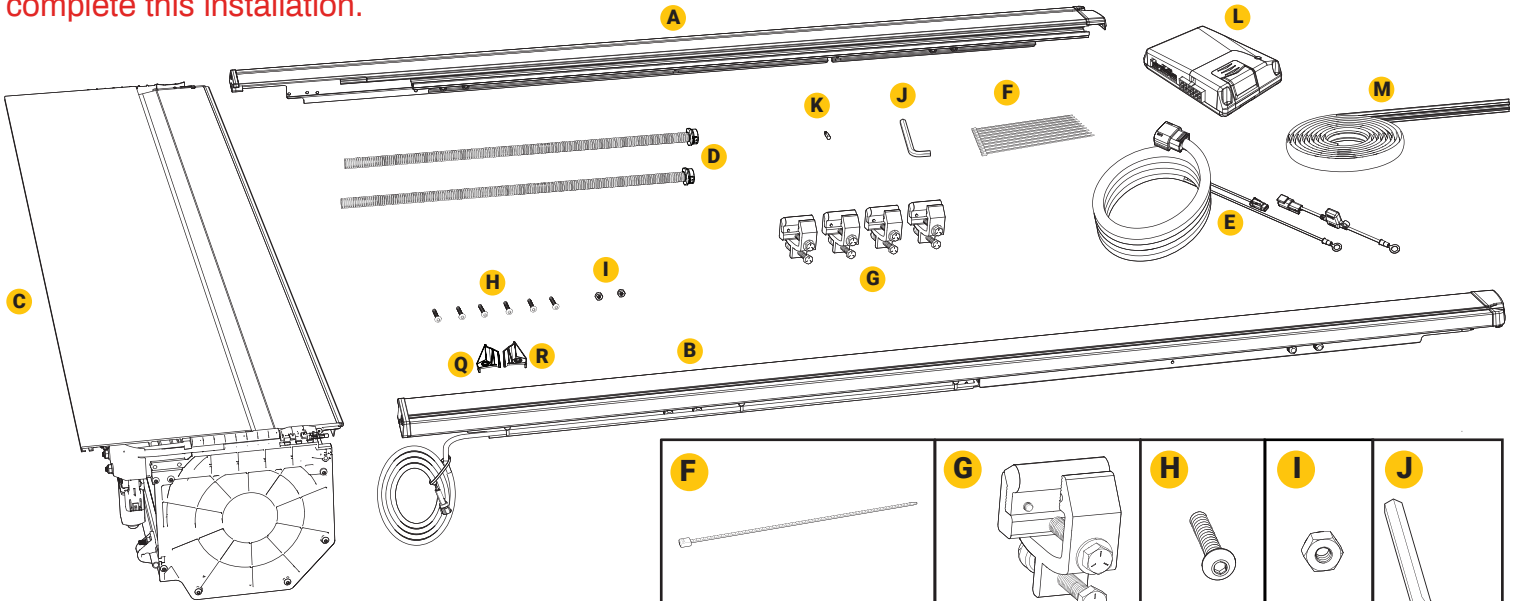

**PARTS FROM BOX**

- A** 1 Passenger side cover rail
- B** 1 Driver side cover rail
- C** 1 Cover rolled into canister
- D** 2 Drain tubes
- E** 1 Main wiring harness (with jumper wire)
- F** 10 zip ties
- G** 1 Clamp kit (4 clamp assemblies)
- H** 6 Canister mounting bolts
- I** 2 Lock nuts
- J** 1 Allen wrench - 6mm
- K** 1 T25 Torx bit
- L** 1 Cabin Module
- M** 1 T-slot seal
- N** 1 T-harness (not pictured)
- O** 1 Bulkhead seal
- P** 12 Plastic shims
- Q** 1 Driver side canister water shield
- R** 1 Passenger side canister water shield

**TOOLS REQUIRED**

- #2 Philips screwdriver
- 9/16" Wrench or Socket
- 3/8" Wrench or Socket with 1/4" drive
- 1/4" Drive ratchet
- Drill and/or Impact driver
- Scissors or Utility knife
- Tape measure
- Deep well socket set & ratchet
- Bit extension for Drill/Impact driver
- Step drill bit or 11/16" Drill bit (Optional)
- Isopropyl alcohol

**BRACKET PARTS INCLUDED IN YOUR KIT**

- S** 4x M6x1 Serrated flange locknut
- T** 6x M6 Flat washer
- U** 6x M6 x 1 x 20mm Torx screw
- V** 2x M8 Flat washer
- W** 2x M8 x 1.25 x 20mm Torx screw
- X** 2x M8 x 1.25 Serrated flange locknut
- Y** 1x Driver side front bracket
- Z** 1x Passenger side front bracket
- AA** 1x Driver side rear bracket
- BB** 1x Passenger side rear bracket

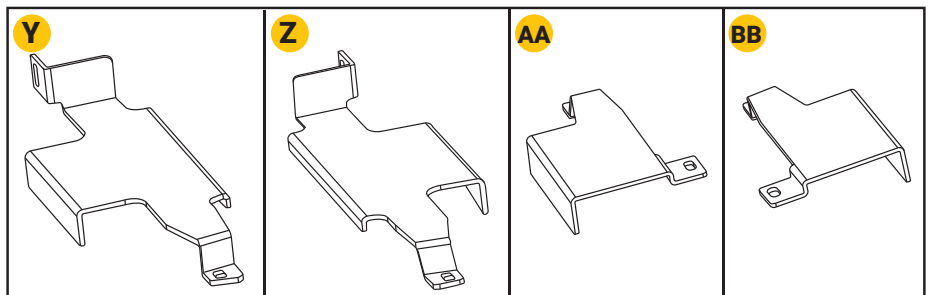
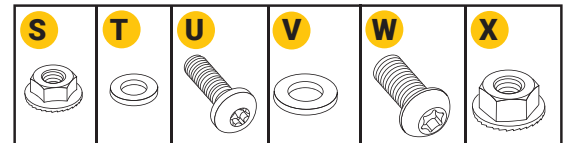

**TOOLS REQUIRED**

- T-30 Torx screwdriver
- T-40 Torx screwdriver
- 10mm Wrench

## 1 Install bulkhead foam seal:

Clean both ends of the header rail with soap and water to remove dirt and debris. Clean the area with isopropyl alcohol to remove wax or grease and to evaporate any remaining water. Allow the surface to dry. Peel off the paper adhesive backing and apply the foam seal (O) to the top of the bulkhead. The seal should be oriented as shown, flush with the inside face and snug between the bed rail caps. Remove any excess with scissors or a utility knife. Apply pressure evenly to the entire seal to ensure proper adhesion.

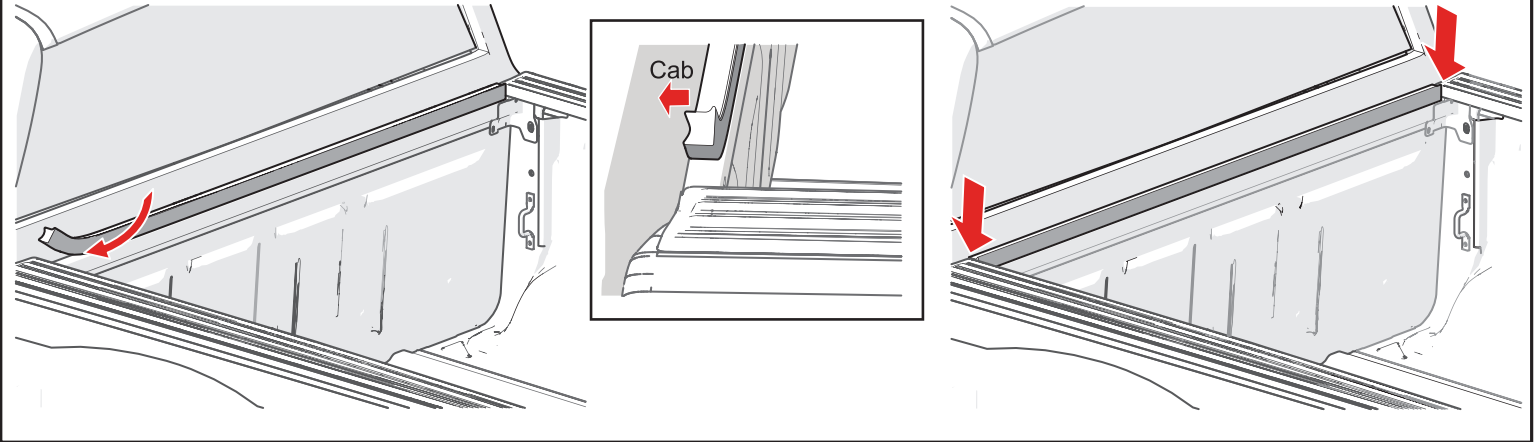

## 2 Install front brackets:

Install brackets at bulkhead and near truck tailgate. For the front brackets (Y & Z) fasten M8 screw (W) and washer (V) through bracket into threaded insert in bulkhead. If bed does not have threaded insert, use provided M8 flange nut (X) on underside of truck bulkhead to secure bracket. Attach other end of bracket to side bed rail by removing plug from attachment point and using M6 screw (U) with a M6 washer (T) and M6 nut (S) to fasten in place. **NOTE:** Remove the two corner clips from the passenger and driver side bed caps, and store them in a plastic bag in the vehicle glove box.

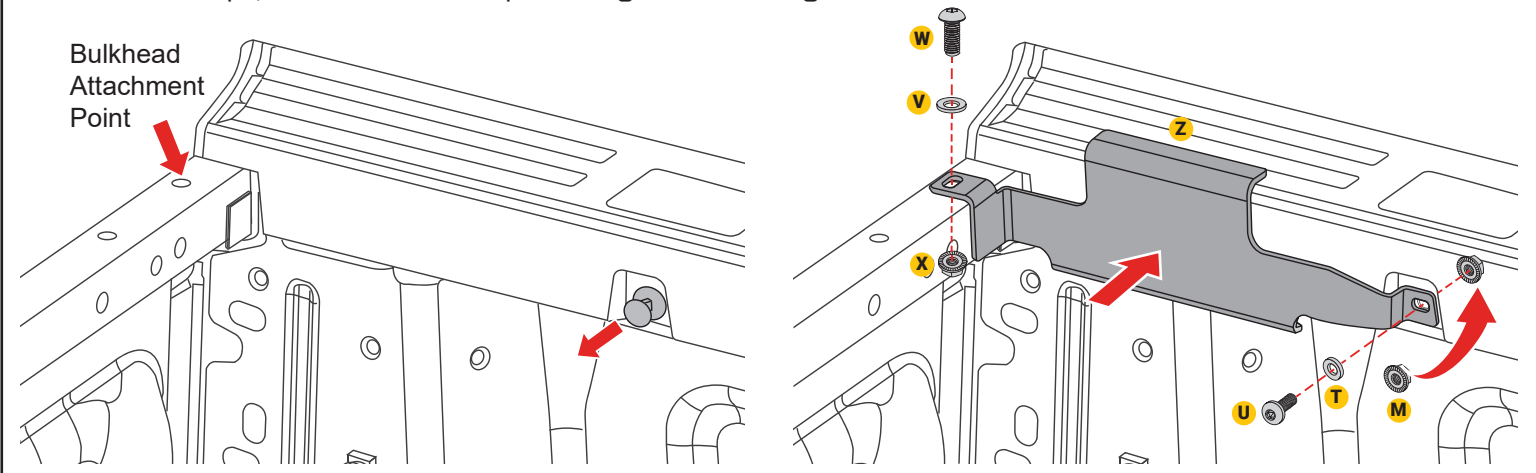

## 3 Install rear brackets:

For the tailgate bracket (AA & BB), fasten M6 screw (U) and M6 washer (T) through bracket into rear bracket (AA & BB) into the threaded insert near tailgate. Attach other end of bracket to side bed rail by removing plug from attachment point and using M6 screw (U) with a M6 washer (T) and M6 nut (S) to fasten in place. **NOTE:** Remove the two corner clips from the passenger and driver side bed caps, and store them in a plastic bag in the vehicle glove box.

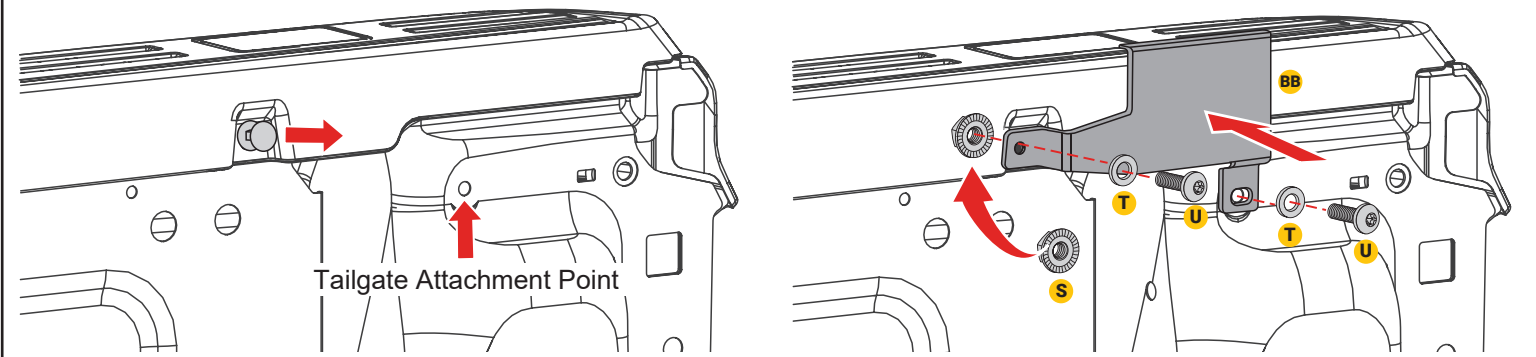

- 4** Remove the screws and shipping brackets, one of each from both sides of the cover (C). Retain the shipping brackets for use in Step 14.

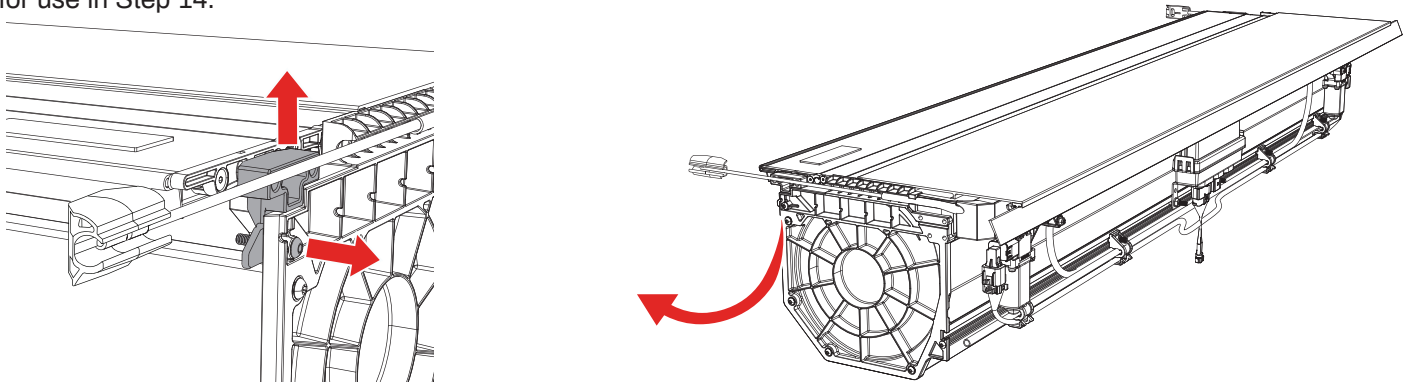

- 5** Pull the tail panel of the cover out of the canister approximately 4 - 6" (203 - 254 mm). While holding the passenger side cover rail (A) near the front, guide the drive carriage into the rail channel as shown. Do this also on the driver side cover rail (B). **NOTE:** Be sure the seal at the front of each rail does not curl under, as shown in the section below.

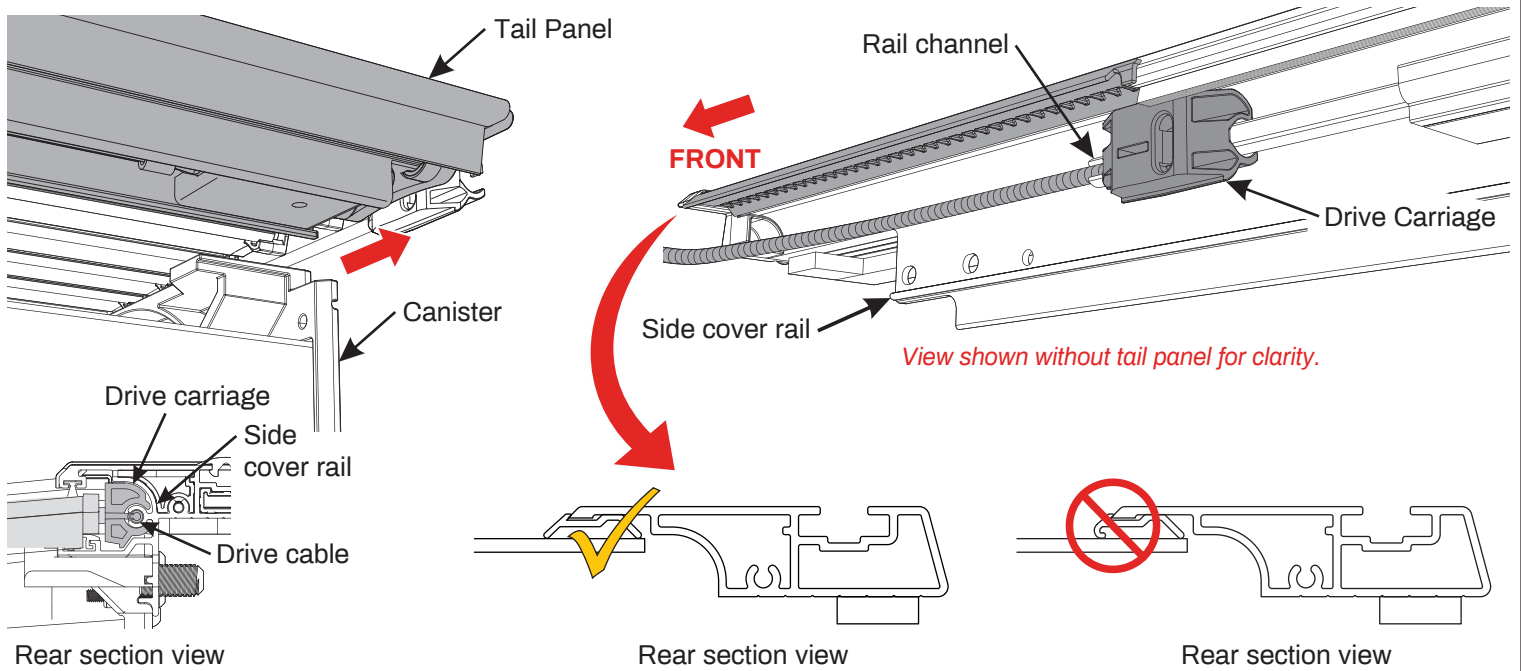

- 6** If you purchased the optional Passenger Side LED Light Kit, do **NOT** plug the connector into the cover module yet. Instead please refer to the one-pager installation sheet provided with that harness, then proceed with Step 8 below. **NOTE:** You must attach the rearmost bolt, along with the lock nut and canister water shield **FIRST**. Then attach the other two bolts. Align the 3 holes in the rail to the corresponding cover holes. Attach the passenger rail (A) to the cover with three canister mounting bolts (H), using a T25 torx bit (K) and a drill or an impact driver with bit extension. Attach a lock nut (I) and passenger side canister water shield (R) to the screw that is closest to the tailgate side of the cover with a 1/4" (6mm) drive 3/8" (10mm) socket. Do this also on the driver side cover rail (B) with the driver side canister water shield (Q).

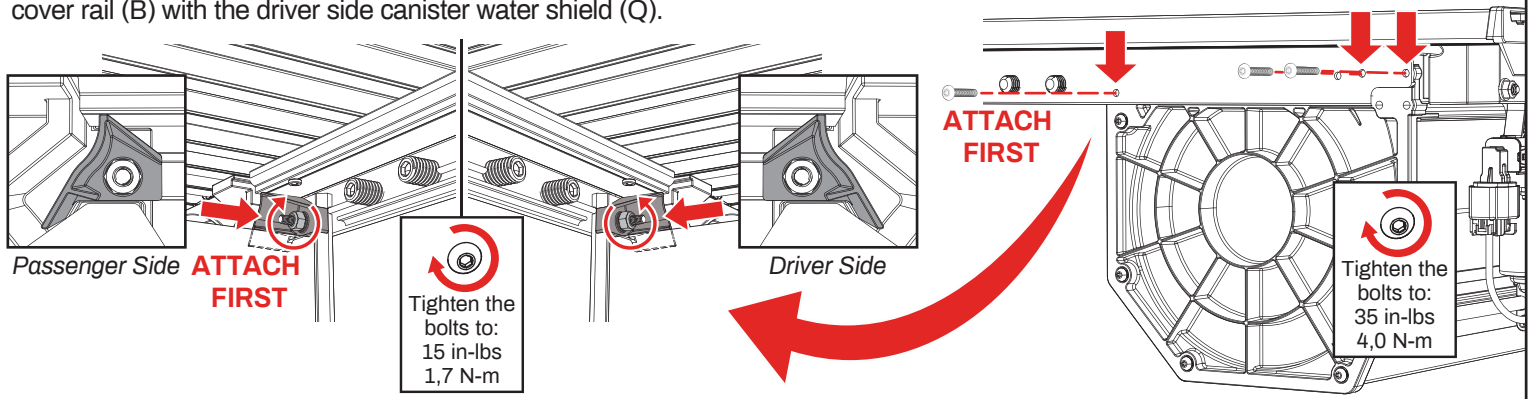

**7** The driver side LED wiring harness with light comes attached to the rail (B), with extra harness tied at the front of the rail, as shown. Remove the tie and continue to route the LED wiring harness around the back of the cover. Route the harness towards the cover module, securing the harness to the two plastic clips. Plug the LED wiring harness connector into the cover modules' connector.

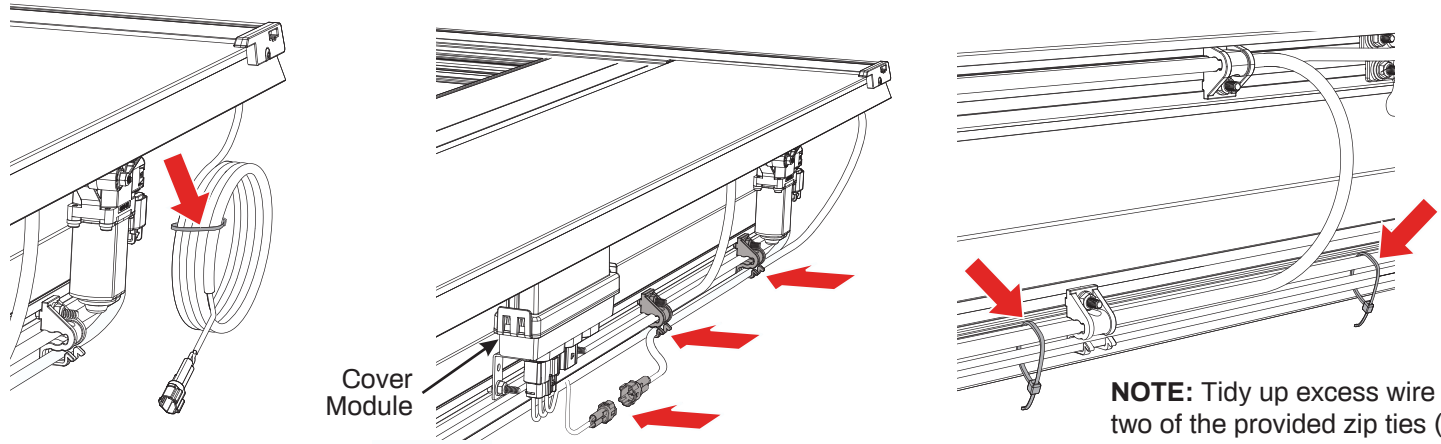

**NOTE:** Tidy up excess wire with two of the provided zip ties (F).

**8** Before routing the main wiring harness (E) from the bed to the battery, first locate your battery in the engine compartment. Determine which side of the vehicle the battery is on - passenger or driver side - and then route the main wiring harness on the same side as your battery. Feed the battery terminal connection end of the main wiring harness (E) into the available pickup bed hole. Bring the wire down between the bed and the cab.

**NOTE:** Make sure to leave enough wire harness in the bed to attach to the cover module later in Step 16.

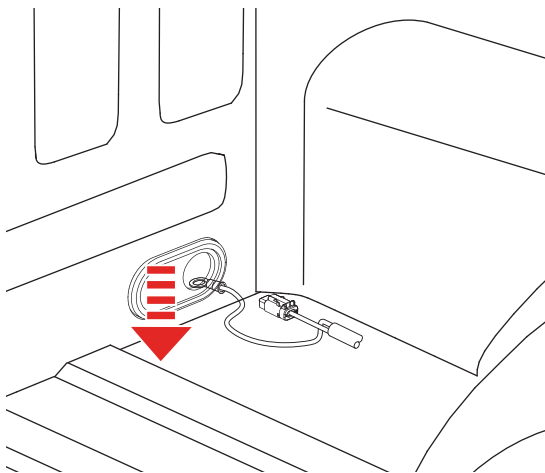

**NOTE:** If there is not a suitable hole in the bed, one may be drilled, but **take great caution to be aware of lines and anything else behind where the hole is drilled. Keep the wires away from moving parts and exhaust.**

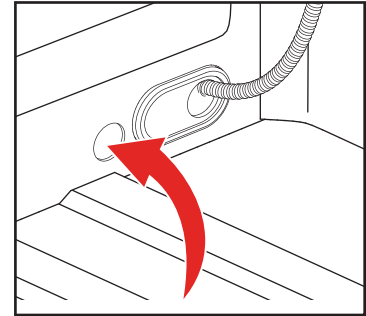

**9** Route the main wiring harness (E) along the frame rails located on the underside. Maintain a wiring route that keeps the wire as high as possible to prevent damage when driving. **Keep the wires away from moving parts and exhaust.**

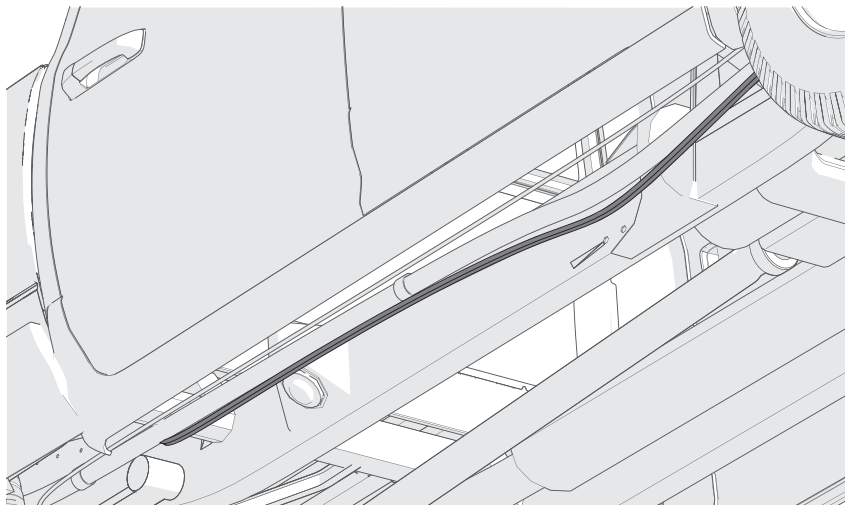

- 10** Finish routing the main wiring harness up to the vehicle's battery, then secure the harness near the battery with a zip tie (F). With the ratchet and necessary socket, connect the negative terminal on the harness to the ground on or near the battery. Next, connect the ring terminal on the positive jumper wire to the positive terminal on the battery. Then connect the jumper wire to the main power harness with the inline connector. Lastly, working from the battery back to the cover, neatly organize and secure the main wiring harness with the provided zip ties. **Keep wires away from moving parts and areas that may become hot, such as the exhaust.**

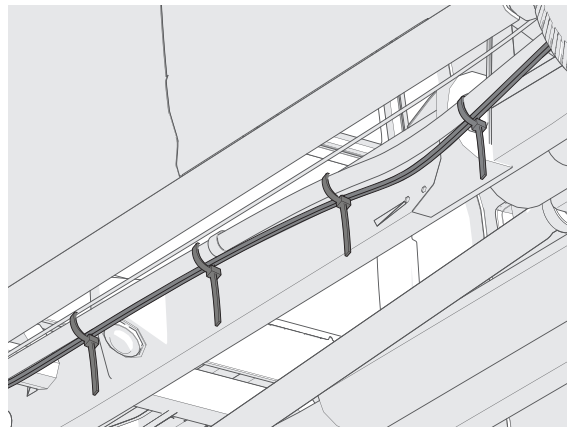
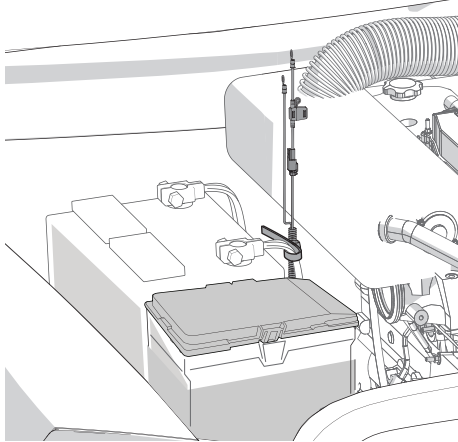

- 11** Remove all of the protective film from the cover (C). Then with two people, lift the assembly onto the truck bed.

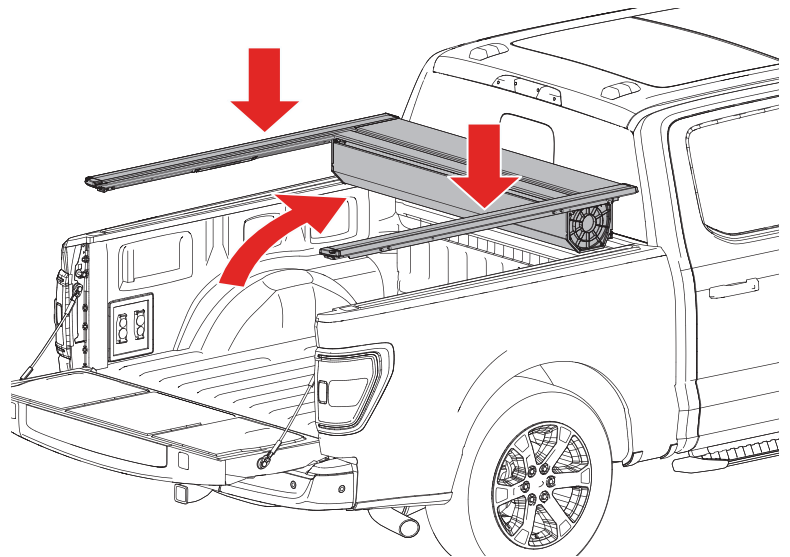
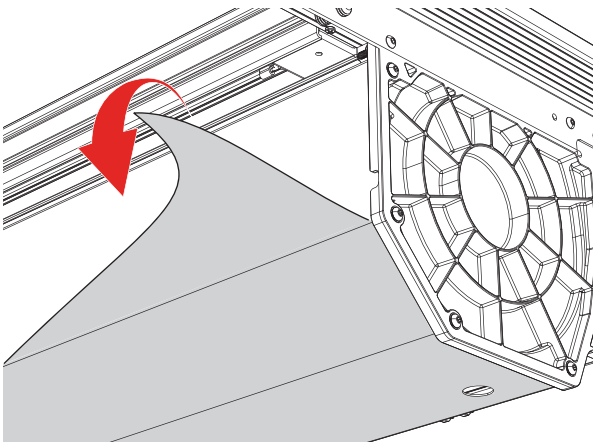

- 12** When placing on the truck bed with two people, place the canister portion of the cover (C) near the bulkhead. The front seal of the cover should lay forward towards the cab and lay flat.

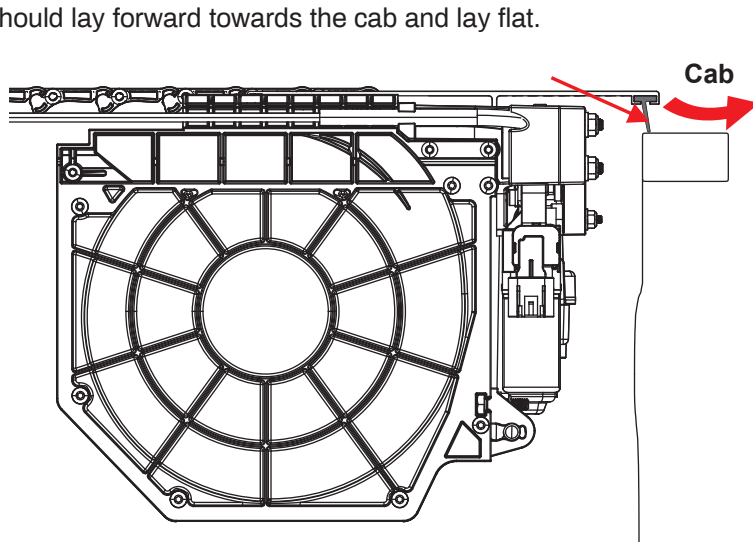

**13** With the cover (C) in place, the front seal lays flat on the bulkhead, but must not extend past the bed rail cap. Trim the seal as needed to ensure that it lays flat.

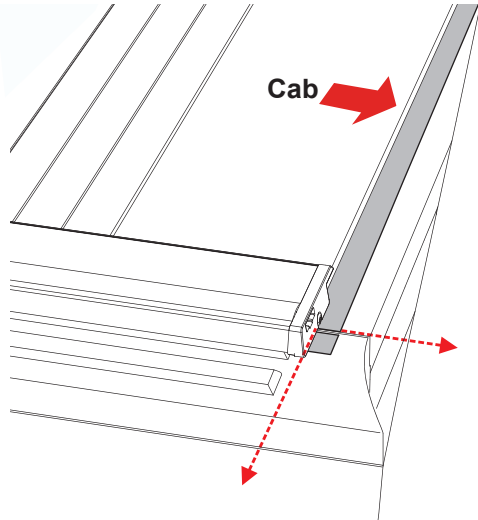

**14** Move the cover (C) back toward the tailgate and position both rails (A & B) to be 1/8" (3.2mm) from the tailgate, using a shipping bracket for spacing.

**NOTE:** The lower rail flange should touch the lower portion of the shipping bracket when spaced properly, as shown below.

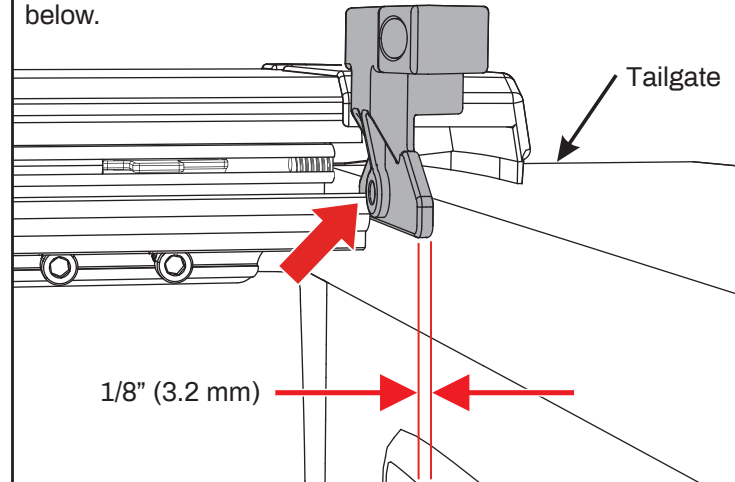

**15** Position the clamps (G) between the adjustment screws both front and back on the passenger side rail (A). The adjustable top jaw of the clamp must be tucked firmly to the top and inside corner of the sheet metal on the truck bed rail. If the jaw does not contact firmly into the corner of the bed flange, remove the clamp and loosen the screws to adjust the jaw. Re-tighten the screws to fully engage the lock washers. Do this also on the driver side rail (B). **Always make sure that two sets of teeth are fully engaged.**

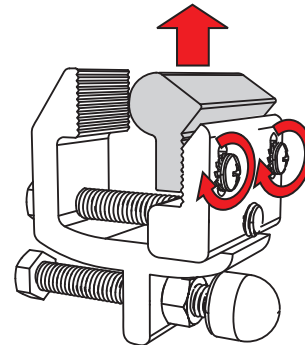
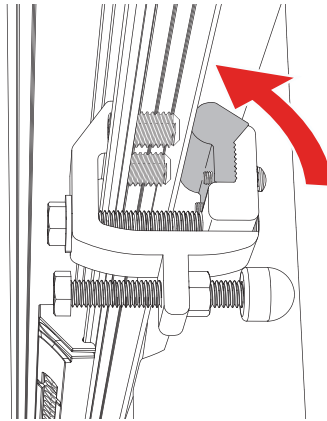

**16** Place a plastic shim (P) between the truck's metal bed rail and the truck's plastic bed cap. Place two plastic shims (P) between the truck's plastic bed cap and the cover's metal bed rail. The shims are placed at every mounting clamp.

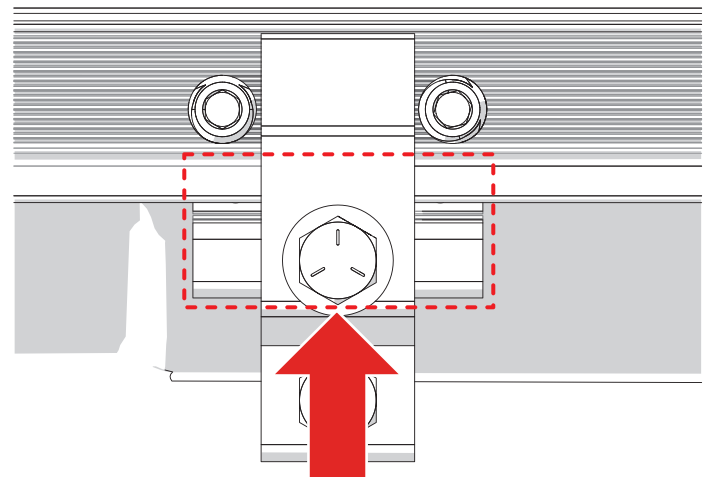
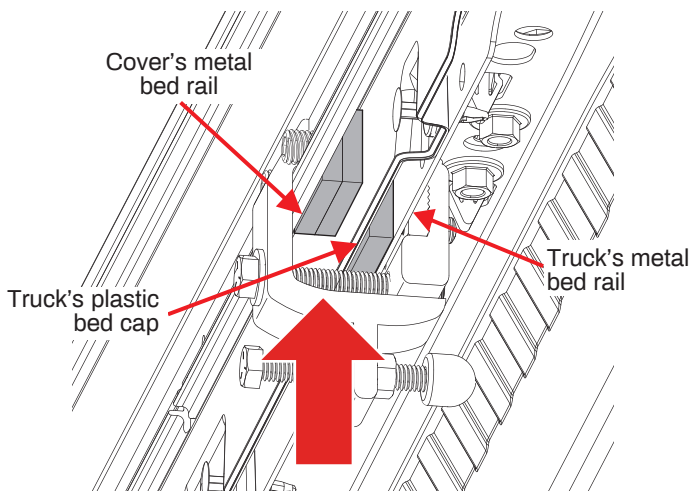

**17** Using a 9/16" wrench, tighten the clamp assemblies (G). It is important to push down on the passenger side cover rail (A) while tightening. The pushing down of the rail will position the rail best to minimize water intrusion, but **Do Not** push down too close to top of tailgate because it will interfere with opening and closing of the tailgate. Do this on the driver side cover rail (B) as well.

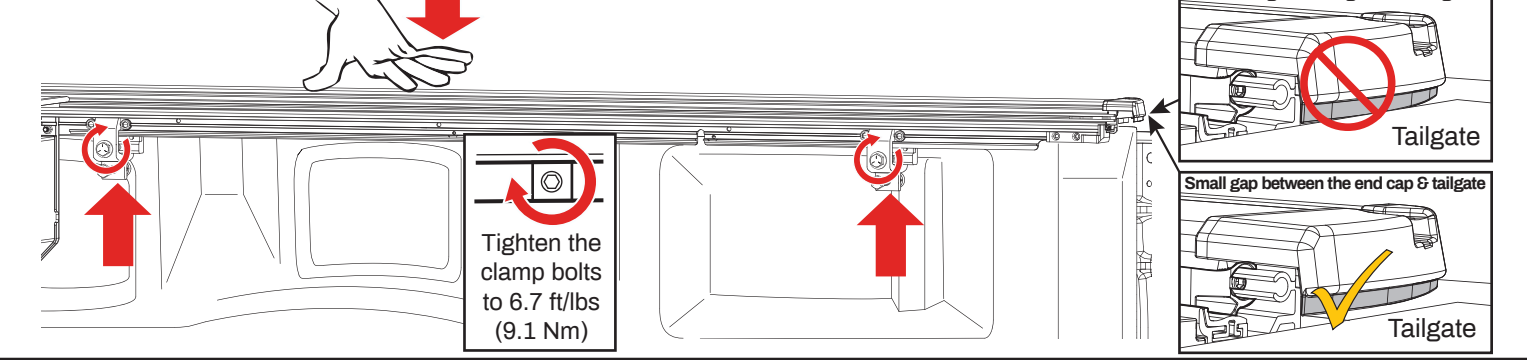

**18** Measure the distance at point A (on top of the cover (C) near the cab). Then measure the distance at points B & C (above each clamp). They must measure the same +/- 1/16" (1.6 mm) as at point A. It is important that the rails are parallel. **If they are NOT, proceed to step 19.** If the measurements are correct, tighten each stand-off bolt on each clamp, so that there is approximately a 2 degree upward tilt to each rail, as shown in the section below. Tighten jam nuts to torque specs below after adjusting the stand-off bolts. Then proceed to step 20.

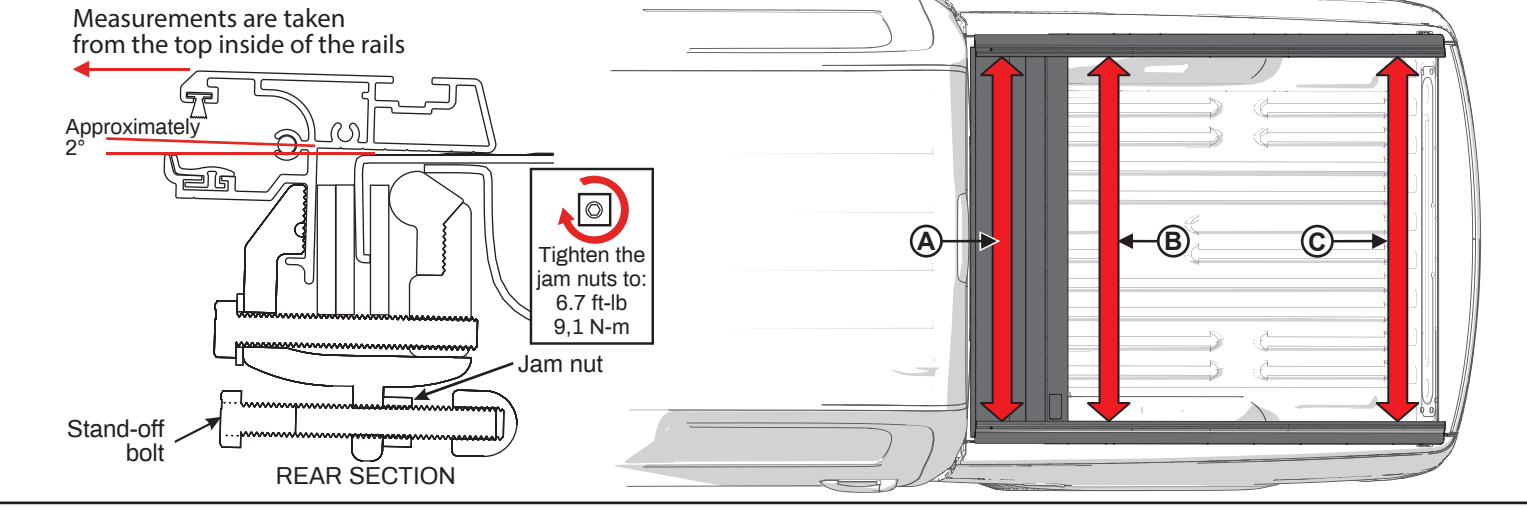

**NOTE:** Due to variations in vehicle designs, the clamps may fit differently on your truck than on our test vehicles. Retrax is not responsible for cover-to-vehicle installation, nor is Retrax liable for any damages resulting from attachment, installation, or use.

**19** Remove the clamps (G) and turn the white adjustment screws with the 6mm Allen wrench (J) to move the rails. One complete turn = 1/16" (1.6 mm). Turn both screws. When properly adjusted, reposition and tighten the clamps as in steps 15-17, then proceed to step 20.

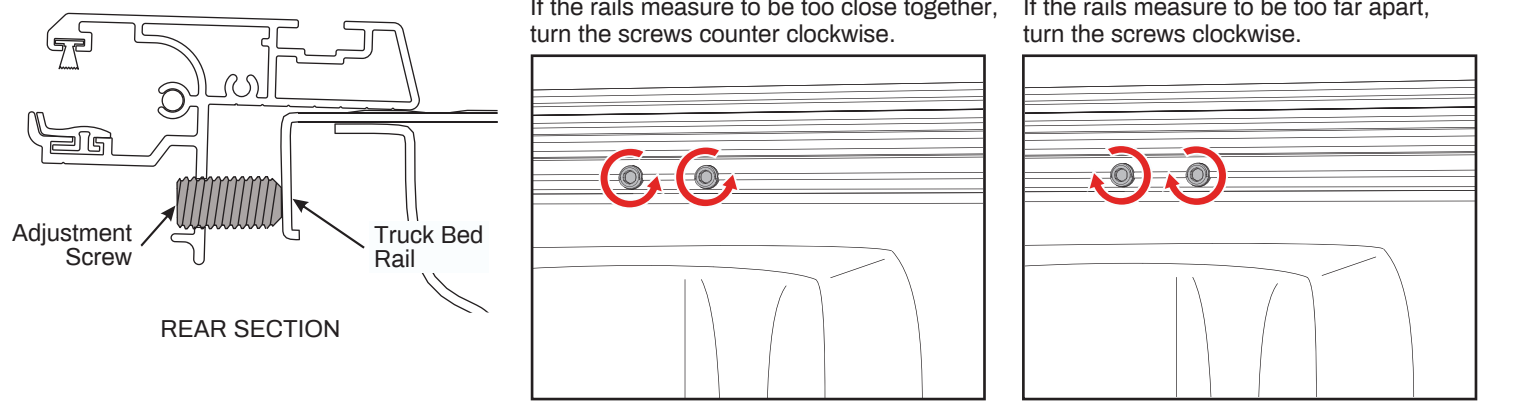

**20** Locate the main wiring harness (E) that was installed previously in steps 8-10. Attach the connector on the wiring harness to the connector on the cover module on the back of the cover (C). Once a connection is made, secure the main wiring harness to the cover (C) with the provided zip tie (F), as shown.

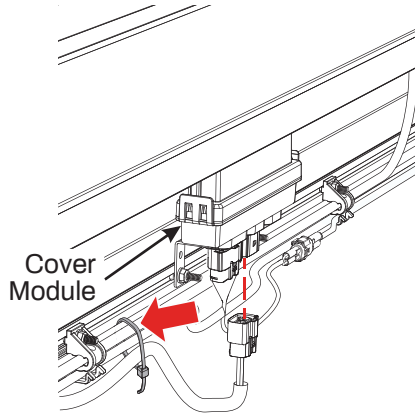

**21** Go back underneath the vehicle where the main wiring harness (E) was zip-tied and pull out all the extra slack in the harness. Neatly organize and secure the extra slack, using another zip tie (F). **Keep the wires away from moving parts and exhaust.**

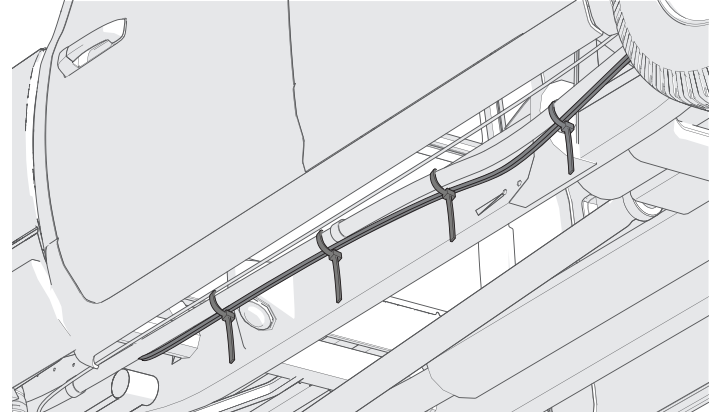

**22** Insert a drain tube (D) into the cover **on both driver and passenger sides**. Rotate to the right; clockwise. The fitting will click twice when secure. Generally the drain tubes (D) will be routed out through a hole drilled in the factory bed plug, otherwise a suitable existing hole must be utilized. Alternately, a new hole can be drilled, but **take great caution to be aware of lines and anything else behind where the hole is drilled.**

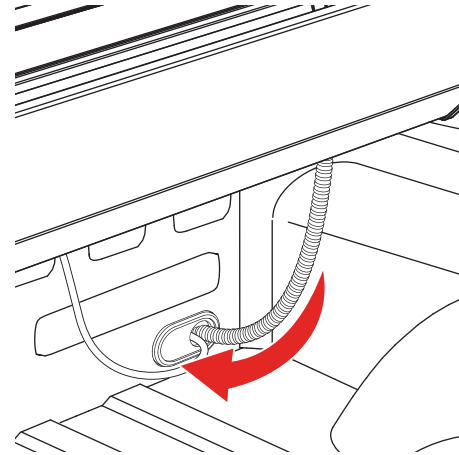
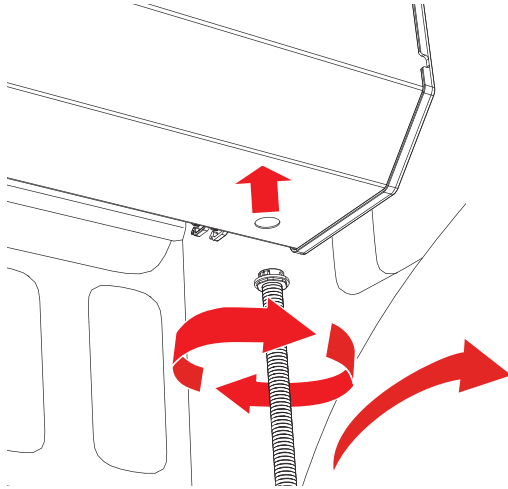

**NOTE:** For better water drainage, be sure to route the drain hose out of the truck in the most direct line as possible.

**23** Use a scissors or a utility knife to cut the T-slot seal (M) into two pieces, to the length of the rail minus the end caps, as shown. Insert the seal into the T-slot on each rail from the top.

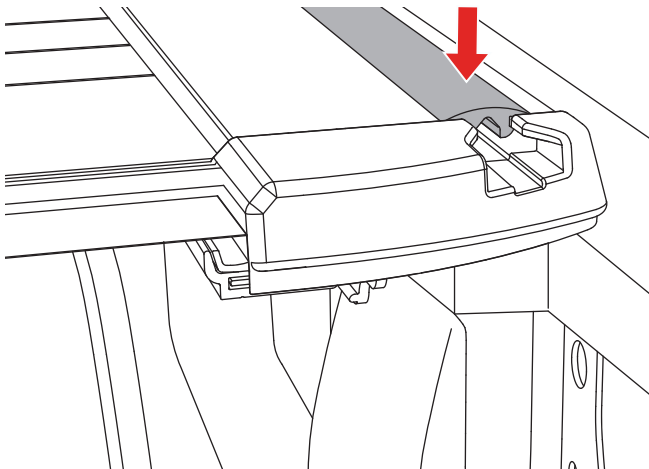

**24** Set up the cabin module (L) and T-harness (N).

Scan this QR code for a link to your specific vehicle's cabin module installation instructions.



Android



iOS

## MANUAL DISCONNECT GUIDE

Manual disconnect is operated by first locating the knob on the underside of the cover. Next, rotate the knob 1/4 turn to disengage the cover from the drive system. While holding the knob in the retracted position, push or pull the cover. This should allow the cover to move freely. To re-engage the cover to the drive system, push or pull the knob 1/4 turn again and manually push the cover back into engagement with the drive system. Alternatively, you can follow the steps below for the automatic cover connection.

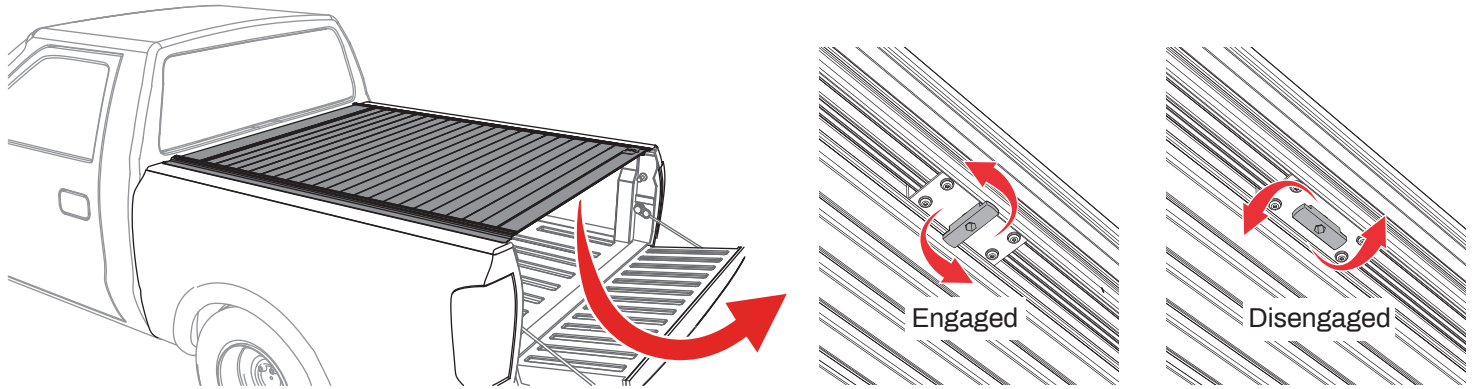

## TROUBLESHOOTING

To create more of a seal between the cover (C) and the tailgate, back the set screws out. **NOTE:** It is paramount to move each set screw the same amount of turns. For example, to bring the cover 1/8" (3.2 mm) closer to the tailgate, back each set screw out 2.5 revolutions. **IMPORTANT:** Make sure the set screws are not backed out too far, or else the cover will make contact with the cover stops, which is not advised.

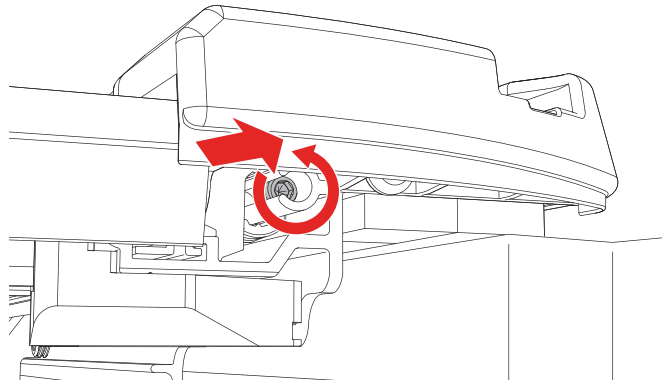

## AUTOMATIC COVER CONNECTION

With the cover in the disengaged state, operate the cover electronically, with either the keyfob, keypad, or phone, so that the drive system brings the carriage in both rails toward the stationary cover. Once the carriages reach the tail slat end of the cover, the cover will start moving and snap into engagement. Cycle the cover to the fully open or fully closed position to ensure proper cover engagement.

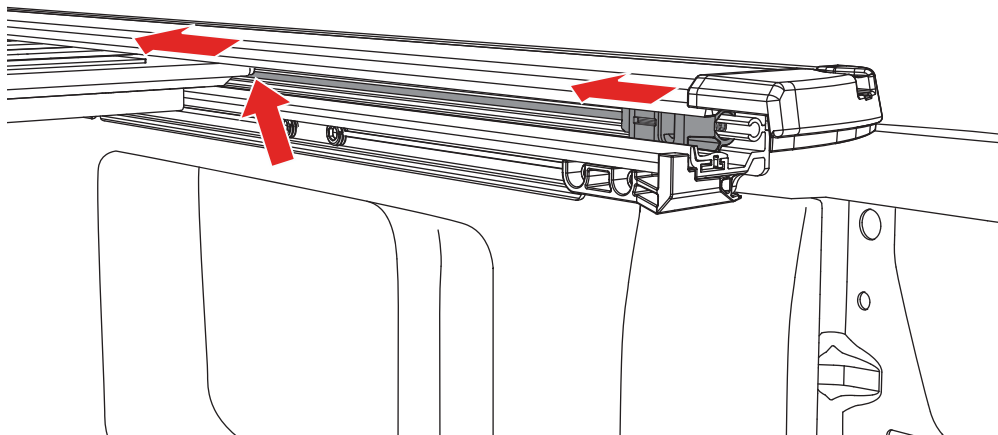

## HOW TO CALIBRATE YOUR TONNEAU COVER SYSTEM

- This step must be performed after the cover is installed, firmware updates are made, and the module programming sequence is complete.
  - To calibrate the drive cables, they must traverse the length of the rail in both directions. While in calibration mode, the cover and/or drive cables will travel at a slower than normal speed.
  - The calibration process will automatically occur every time the system enters Pairing Mode, or if the power is reset to the Cover Module.
  - The calibration process can be performed if at any time the carriages become unaligned with one another.
  - While performing the calibration process, the Anti-Pinch feature of the cover will not function.
  - The calibration process can be completed with or without the cover connected to the drive carriages. It is recommended to perform the initial calibration cycle with the cover disconnected from the carriages.
1. Ensure the cover is disconnected from the carriages in each rail and press the **lock** button 3X on the OEM key fob to send the carriages down to the tailgate end of the rails.
    - a. The calibration process can be initiated from any of the user options; OEM Keyfob, User App, and 5-Button Keypad.
  2. Once the cables have reached the tailgate end of the rails and have stopped moving, press the **unlock** button 3X on the OEM fob to bring the carriages all the way back to the cab end of the cover.
  3. As the carriages reach the tail panel of the cover, they will engage and the calibration process will be complete.

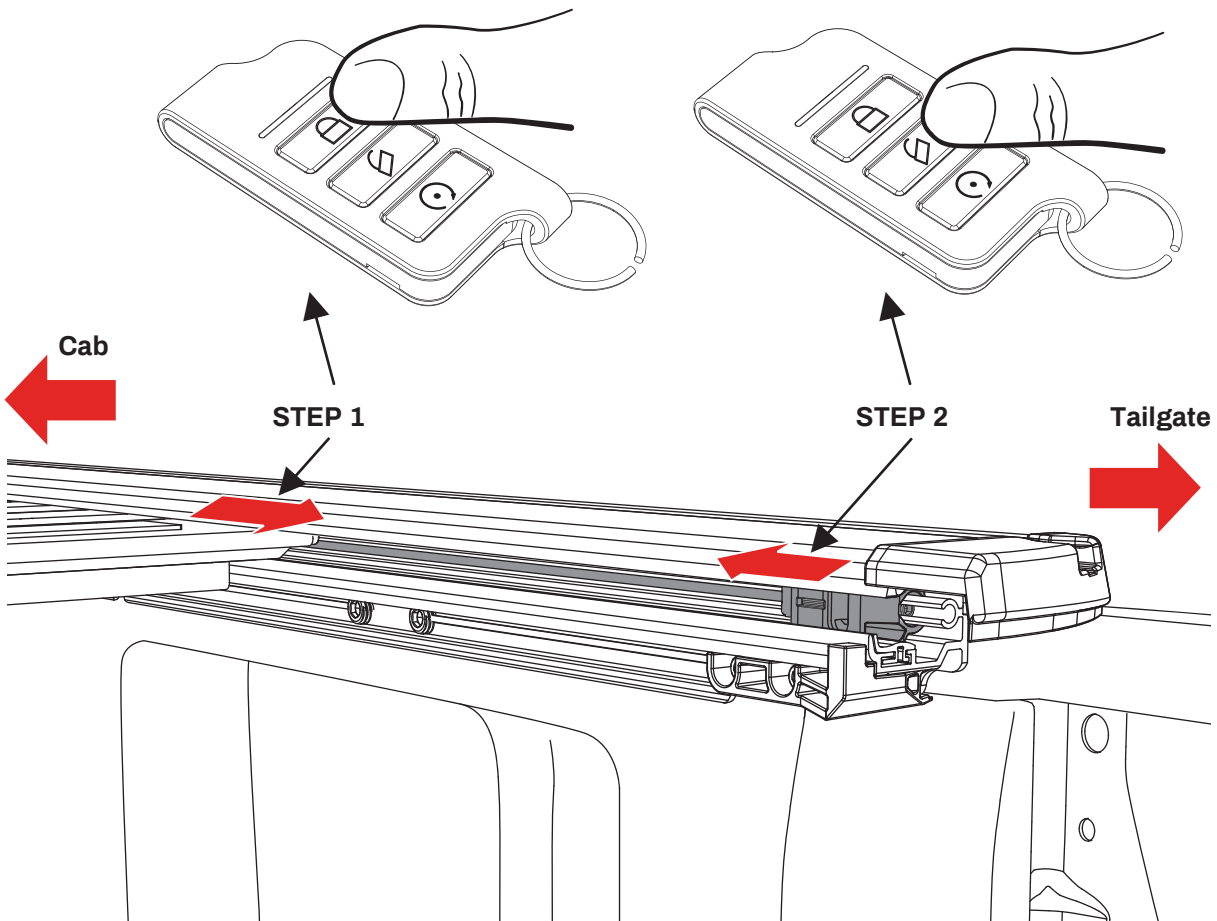

## COVER CARE AND MAINTENANCE

Clean with mild automotive soap and water only. Do NOT use any strong chemicals or cleaners.

Do NOT wax your Retrax cover. The weather-stripping on your cover may absorb soapy residue from a car wash, so we recommend wiping down the inside of your rails from time to time.

If the vehicle is driven frequently in dusty conditions, it is recommended to periodically clean dirt and dust from inside the rails and spiral canister with a wet towel. To further improve cover performance, it is acceptable to apply a thin film of plastics safe, silicon based lubricant.

It is recommended that you periodically check that the cover is securely attached to your truck bed. Inspect the clamps and front mounting bolts to ensure they were properly installed and have not come loose or knocked out of adjustment during operation. Covers that are used with high frequency or that are subject to the vibrations and impact from rough roadways can cause the cover to require adjustment.

## USE

### USE OF COVER WITH OEM KEY FOB

Press the lock button three times to close.  
Press the unlock button three times to open.

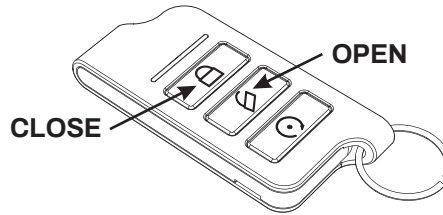

To enter "Cinch" mode to secure loose cargo in place against the tailgate, press the lock button three times. The cover will meet resistance and retract a couple inches. Press the lock button three times again and the cover will retract and cinch the object in place.

### USE OF COVER WITH PHONE APP

Press the open icon to open the cover.  
Press the close icon to close the cover.

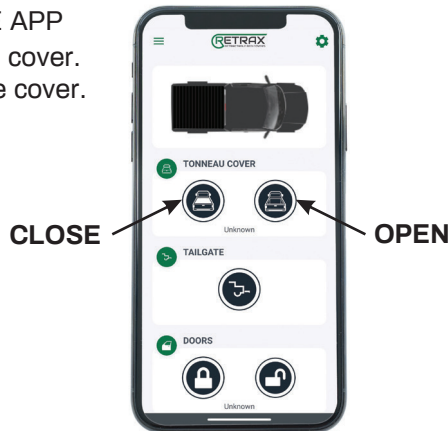

### 5-BUTTON KEYPAD INSTRUCTIONS (OPTIONAL)

## Retrax EQ

### ACCESS CODE

#####

**UNLOCK ALL DOORS:** Press the 3/4 key within 5 seconds of entering the 5-digit access code.

**LOCK ALL DOORS:** Press and hold 7/8 and 9/0 buttons simultaneously for at least 2 seconds.

**OPEN COVER:** Press 1/2 key within 5 seconds of entering the 5-digit access code.

**CLOSE COVER:** Press 9/0 key within 5 seconds of entering the 5-digit access code.

**OPERATE THE TAILGATE:\*** Press the 5/6 key within 5 seconds of entering the 5-digit access code.

\*Powered tailgates only.

800-206-4070

Scan this QR code for a link to your specific vehicle's User App.



Android



iOS

## SAFETY INSTRUCTIONS

- Do NOT tow your vehicle from the rear with the cover on your vehicle. If towing from the rear is required, the cover MUST be removed from the vehicle and properly stored.
- All large and heavy cargo must be secured by straps.
- NEVER allow children or pets to occupy the truck bed while the cover is closed.
- The cover is not airtight. Special care is required to keep cargo clean and dry.
- Tonneau covers won't prevent theft of contents inside the truck box.

## Limited Warranty

### WARRANTY COVERAGE

This truck bed cover is warranted against defects in materials or workmanship as follows. This warranty is void if the product has been damaged in an accident, or due to neglect, unforeseeable use, improper installation, improper servicing, or other cause not arising out of defects in material or workmanship.

The truck bed covers carries a limited warranty for five (5) years from the original date of purchase, subject to the terms below.

### WARRANTY IS NOT TRANSFERABLE

The warranty is to the initial consumer purchasing the truck bed cover and it is not transferrable to a subsequent end user. Proof of purchase may be required to enforce these warranty rights.

### WARRANTY CONDITIONS

Failure to follow these care and use instructions will void the warranty:

- Clean with mild automotive soap and water only. Do not use any strong chemicals or cleaners. Lubrication of the rails or sealed ball bearings will void the warranty.
- Cargo must be secured at all points when the vehicle is in motion. Failure to adequately secure the cover or tether strap can result in damage and will void the warranty.
- Check all clamps and retention mechanisms for tightness after a week of driving following installation (or re-installation) of the cover and periodically thereafter.
- Before opening, the cover must be free of all foreign materials including snow and ice.
- Do NOT tow your vehicle from the rear with the cover on your vehicle. If towing from the rear is required, the cover MUST be removed from the vehicle and properly stored.

### WARRANTY PERFORMANCE

If all warranty conditions are met, a defective truck bed cover or hardware component will either be repaired or replaced (at our option). We reserve the right, for any warranty, to substitute a newer model or bed cover having a similar form and function, to offer a warranty discount on an entire replacement system, and/or provide remedies other than those mentioned in this document.

### WARRANTY RETURN

A Return Material Authorization number must be obtained from our Customer Service Department prior to returning any product. We may require the original item to be returned postage prepaid for final determination. Shipping charges will apply for any repair or replacement. Other than postage or shipping charges, no charge will be made for repair or replacement under this warranty.

This warranty gives you specific legal rights. As a consumer, you may also have additional rights and remedies under the laws of your state.

### WARRANTY REGISTRATION

Warranty registration must be on file and/or proof of original purchase (detailed and dated receipt) required for warranty to be effective.

Register online at <https://realtruck.com/retrax-warranty>

**REGISTER  
YOUR  
WARRANTY  
ONLINE**



When calling or emailing, please be prepared to reference your part number and serial number. The serial number is located under the cover next to the lock assembly on the tailgate extrusion. The serial number is 8 - 14 digits and may or may not include a letter in it.

