

Fuel Pressure Regulator DWR2000 (6-2000-FRB, 6-2000-FRT)



The *DWR2000* regulator is engineered to support EFI engines producing between 750HP and 4000HP. This regulator features our largest diaphragm and inlet/outlet port configuration to manage the massive flow needed to support 4000HP. It comes in your choice of anodized black or titanium finish.

- Massive 49mm diaphragm and -10AN inlet and outlet ports
- Compatible with all fuels including methanol and ethanol
- Supports up to 4000hp on Ethanol
- Supports up to 4800hp on Gasoline
- Supports up to 1600hp on Methanol
- 2 psi per turn precision ball bearing adjustment
- Multi-directional bracket for Installation flexibility

Specifications

Weight	13.92 oz (395 grams)	Pressure Range	30-120psi
External Materials	Anodized T6061 Aluminum	Flow Rating	2000 LPH
Hardware/Brackets	300 Stainless Steel	HP Rating (E85)	4000 HP
Tension Spring	Stainless Spring Steel	Gauge Port Fitting	1/8" NPT
Diaphragm	49mm Fiber-Nitrile	Inlet Ports	Quad -10 AN ORB
Vac/Boost Ref Port	1/16" NPT	Return Port	Single -8 AN ORB

Dimensions

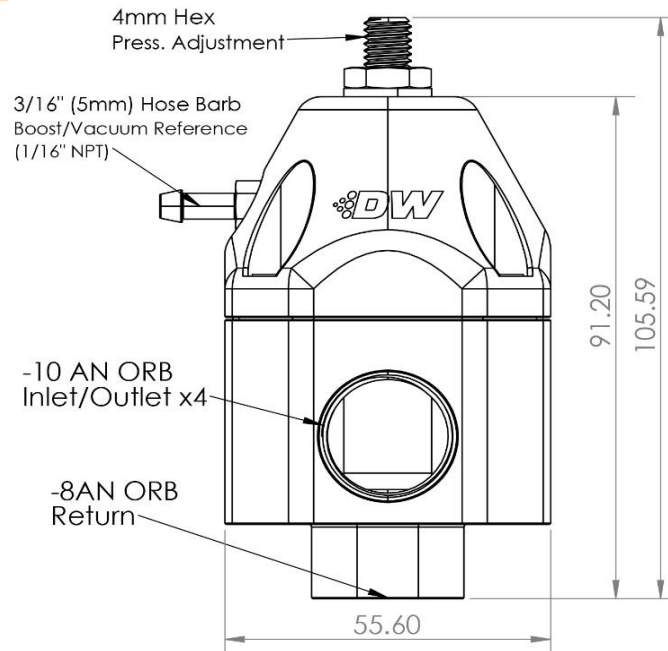

THIS PRODUCT MAY BE USED SOLELY ON VEHICLES USED IN SANCTIONED COMPETITION WHICH MAY NEVER BE USED UPON A PUBLIC ROAD OR HIGHWAY, UNLESS PERMITTED BY SPECIFIC REGULATORY EXEMPTION