

## ⚠️ IMPORTANT

### READ BEFORE YOU BEGIN INSTALLATION

**IT IS CRITICAL FOR YOUR SAFETY THAT YOU CAREFULLY READ AND FOLLOW THE SAFETY CAUTIONS AND INSTALLATION INSTRUCTIONS BOTH PRIOR TO AND DURING INSTALLATION.**

#### USER SAFETY CAUTION

During installation, be mindful of the potential for sharp edges on the product or vehicle. Taking proper safety precautions helps ensure a safe and smooth installation process.



**Always wear protective gloves and handle components with care to reduce the risk of injury.**

#### TEMPERATURE SURFACE CAUTION

During high temperatures or extended sun exposure, surfaces of this product may become hot to the touch, posing a risk of burns or injury. Use caution when handling the product in hot weather and allow time for it to cool before contact.



**Always check surface temperature before use to ensure safe handling conditions.**

#### FASTENER TORQUE CAUTION

All fasteners must be tightened to the specified torque values provided in the installation instructions to ensure proper fit and safe operation of the tonneau cover. Under- or over-tightening can lead to product failure, potential damage to your vehicle, injury, or safety hazards while driving.

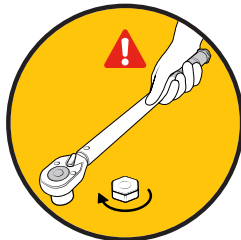

**Always use a calibrated torque wrench and follow the specifications in the installation instructions.**

#### PINCH POINT SAFETY CAUTION

This tonneau cover may create pinch points when closing or operating near solid surfaces such as the truck bed rails or tailgate. To prevent injury, keep hands, fingers, and other body parts clear of moving parts during operation.



**Always operate the cover slowly and with caution to ensure safe and proper use.**

# IMPORTANT

## READ BEFORE YOU BEGIN INSTALLATION

IT IS CRITICAL FOR YOUR SAFETY THAT YOU CAREFULLY READ AND FOLLOW THE SAFETY CAUTIONS AND INSTALLATION INSTRUCTIONS BOTH PRIOR TO AND DURING INSTALLATION.

### ENTRAPMENT SAFETY WARNING

This tonneau cover does not feature a manual release mechanism from inside the truck bed. To prevent the risk of entrapment, never allow anyone to be inside the bed of the truck when the cover is closed.

**Always ensure the area is clear before closing the cover, and keep the cover securely latched when not in use to avoid accidental closure.**

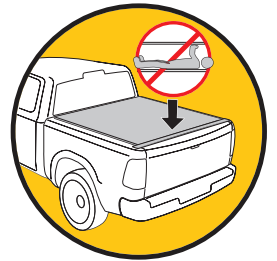

### CARGO TRANSPORT WARNING

Do not attempt to close the tonneau cover over cargo that is taller than the depth of the truck bed.

Never force the cover to close improperly.

#### Forcing the cover can:

- Prevent the cover from lying flat and latching securely.
- Damage the cover's hinge and cause the cover to kink.
- Damage the rear tail panel and cause it to become detached.

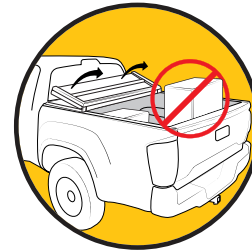

Any damaged or missing parts?

Parts will be shipped to you directly.

Call 800-877-2588, Mon - Fri, 8:30 a.m. - 6:00 p.m. EST

**NOTE:** It is important that all areas where the bed cover mounts are clean and free of debris prior to installing.

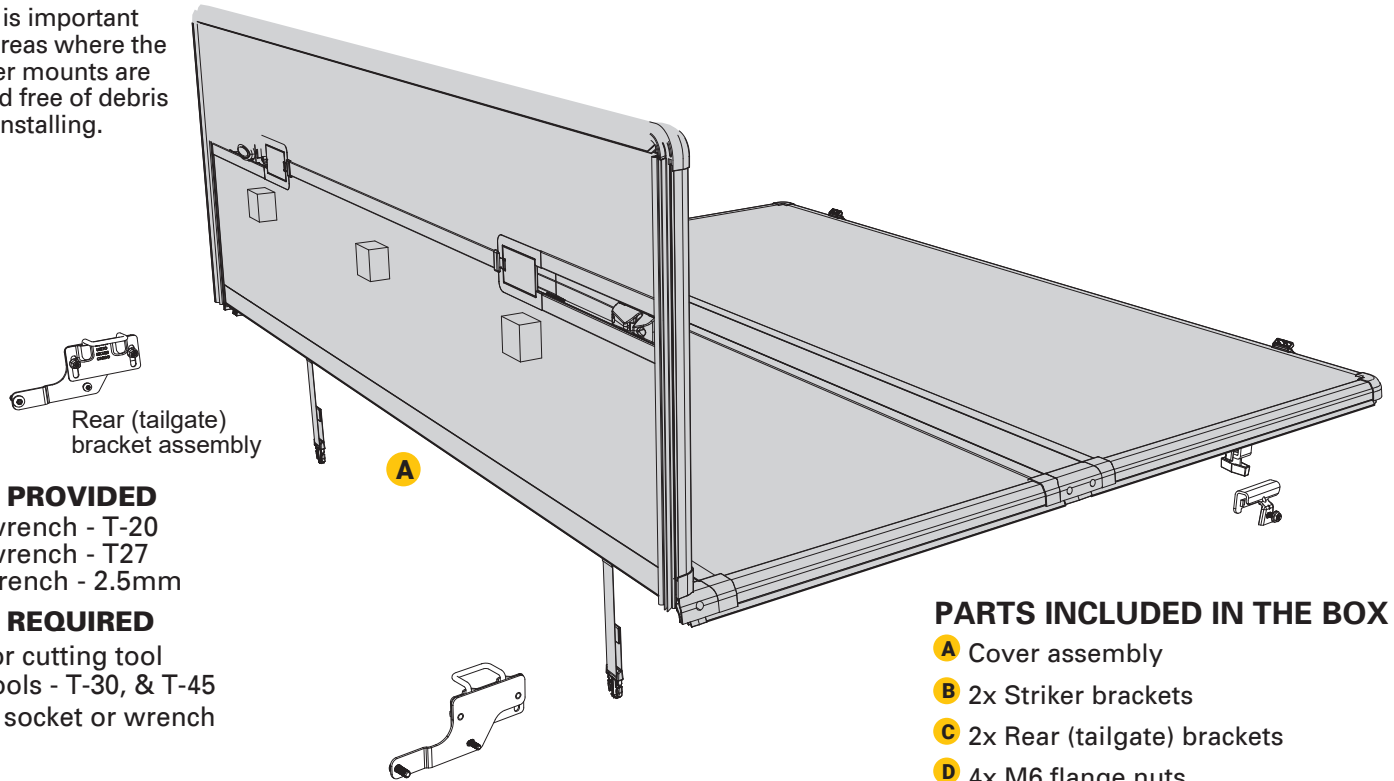

**TOOLS PROVIDED**

- Torx wrench - T-20
- Torx wrench - T27
- Hex wrench - 2.5mm

**TOOLS REQUIRED**

- Knife or cutting tool
- Torx tools - T-30, & T-45
- 10mm socket or wrench

**PARTS INCLUDED IN THE BOX**

- A** Cover assembly
- B** 2x Striker brackets
- C** 2x Rear (tailgate) brackets
- D** 4x M6 flange nuts
- E** 2x Front (cab) latch brackets
- F** 4x Torx screws, T- 30
- G** 2X M6 flange locknuts
- H** 1x Bulkhead seal kit

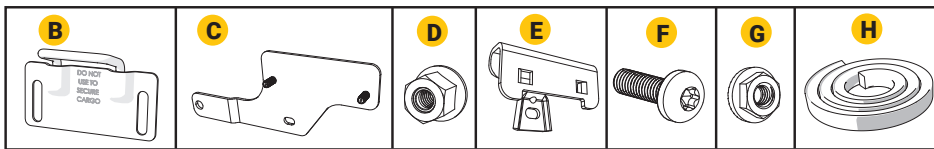

**1** To install the bulkhead seal (H) clean the top of the bulkhead where the seal will go with soap and water to remove dirt and debris. Then clean the same area with isopropyl alcohol to remove wax or grease and to evaporate any remaining water. Allow the surface to dry. Peel the backing from the seal and apply it to the top of the bulkhead. Apply pressure evenly to the entire seal to ensure proper adhesion. The seal should be flush with the front edge of the bulkhead and snug between the rail caps.

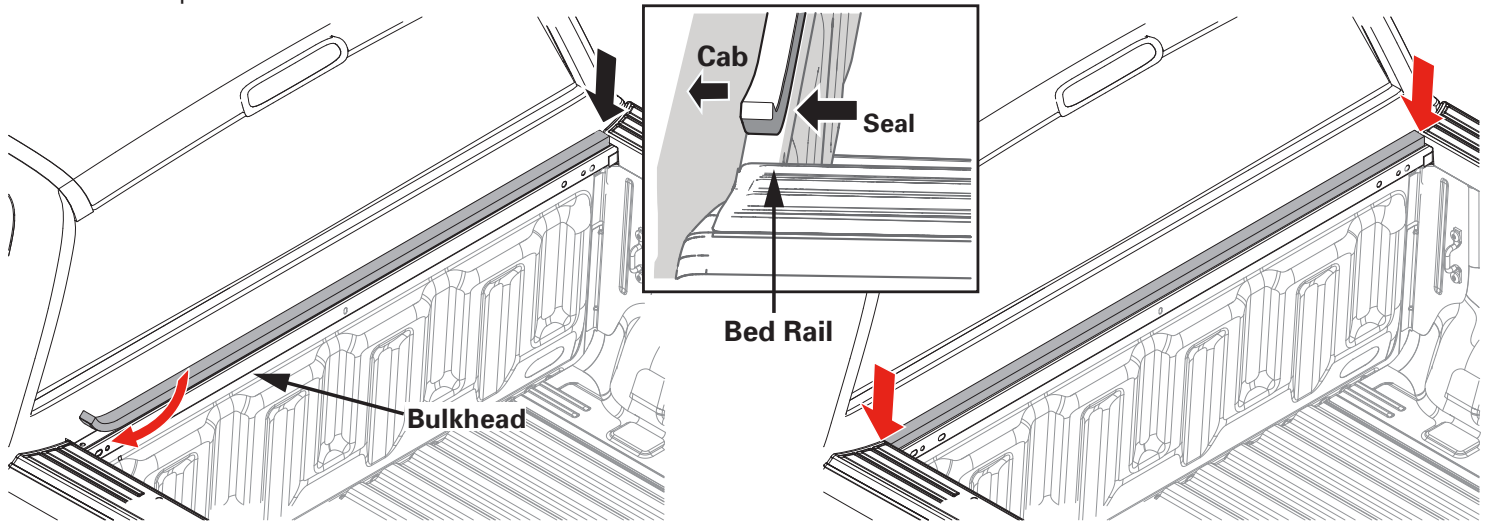

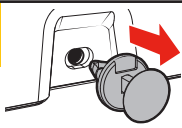
**2**

Before installing the latch brackets, first remove the factory clips from the front bed cap recesses, on both sides. First pry the center of the clip out, then pry the entire clip out.



Place the front (cab) latch bracket (E) into the front recess in the truck bed rail. Thread the Torx screw (F) through the bracket, through the bed rail and into the M6 flange locknut (G). With a 10mm wrench and a T-30 Torx tool tighten the Torx screw to **8 ft-lbs (11Nm)**.

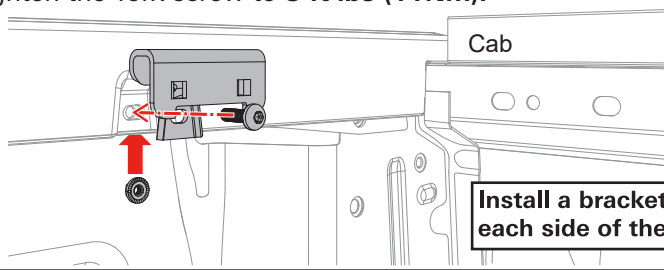

Install a bracket on each side of the truck.

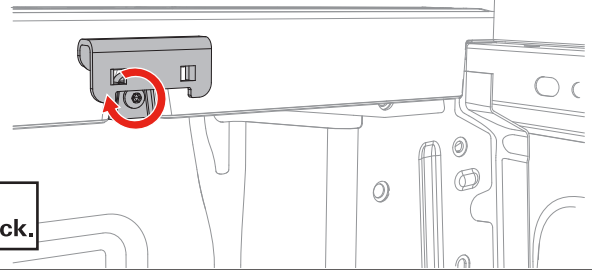
**3**

Remove the factory flange bolt, place the rear latch bracket (C) as shown and replace the factory flange bolt along with installing a Torx screw (F). Tighten the factory bolt (T-45) to **16 ft-lbs (22Nm)** and the Torx screw (T-30) to **8 ft-lbs (11Nm)**.

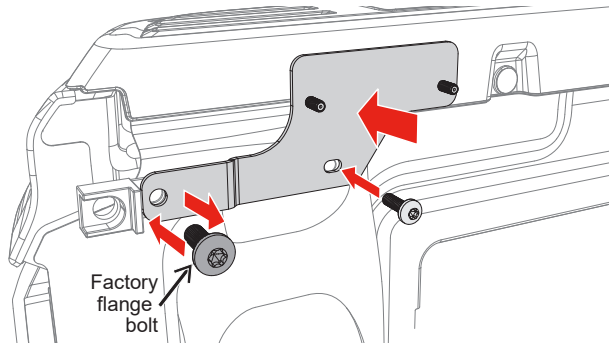

Place the striker bracket (B) onto the latch bracket and secure with two M6 flange nuts (D). Hand tighten the flange nuts for later alignment.

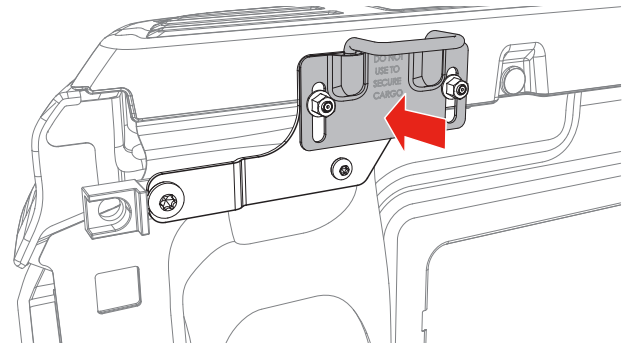
**4**

Place the folded, assembled bed cover over the cab end of the truck bed.

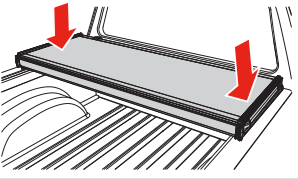
**5**

Unfold the bed cover fully and adjust the position over the truck bed for proper front (cab) and rear (tailgate) alignment. When positioned front and back, the tailgate seal should contact the tailgate with the first two fins.

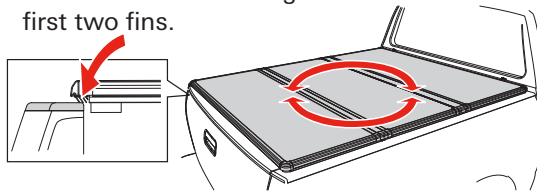
**6**

Carefully refold the bed cover without shifting its position on the truck bed.

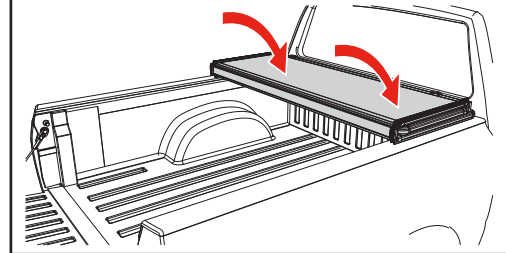
**7**

Slide the front (cab) clamp at an angle toward the bed rail and swing it down.

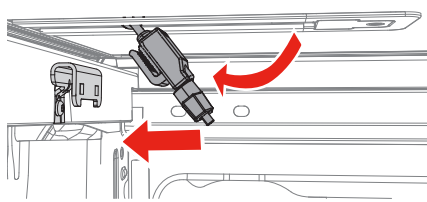

Rotate the body of the clamp up or down to match it's position with the bracket.

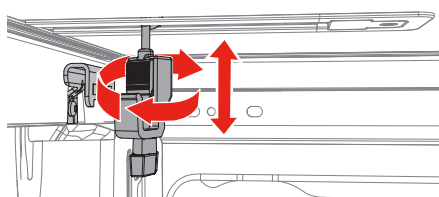

### IMPORTANT

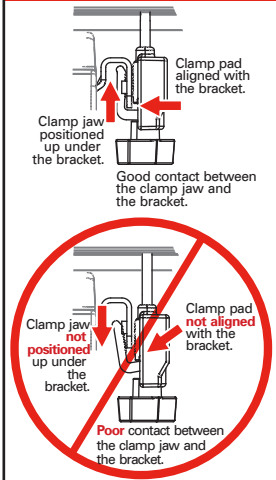

The optimal position of the clamp body is to match the bottom of the ridges to the bottom of the bracket.

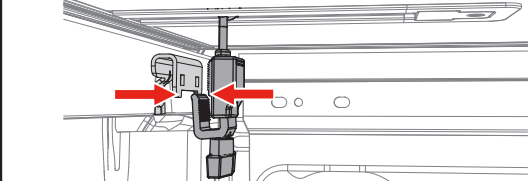

Swing the clamp under the bracket and tighten by hand. **DO NOT** over tighten or use a wrench.

Push down on the bed cover while tightening to ensure proper seal engagement.

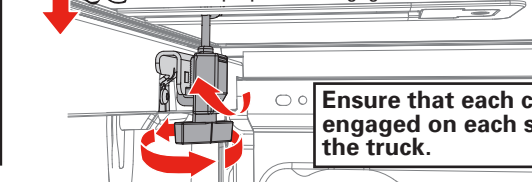

Ensure that each clamp is engaged on each side of the truck.

**8** The tethers come installed on the bed cover hinge with a 9 carabiner clip at the other end. Install the carabiner end by clipping it to the accessory hook at the front / cab of the bed. Attach both the driver and passenger sides.

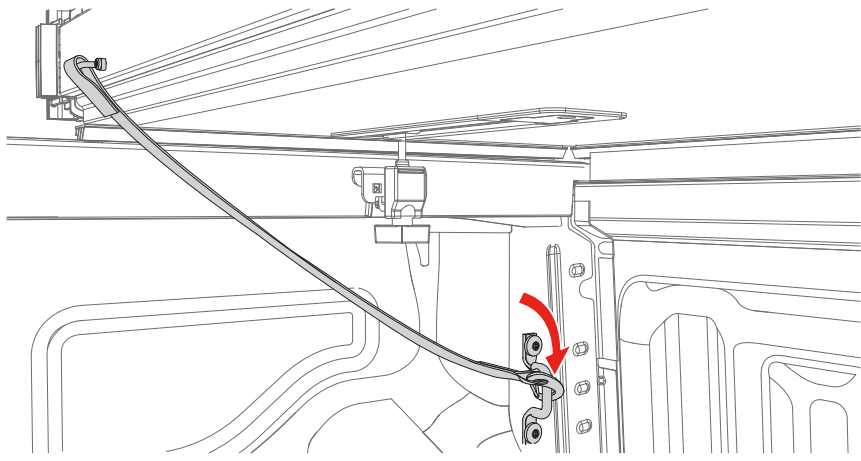

**9** With the tailgate open, the front (cab) clamps and the tethers secure, completely close the bed cover.

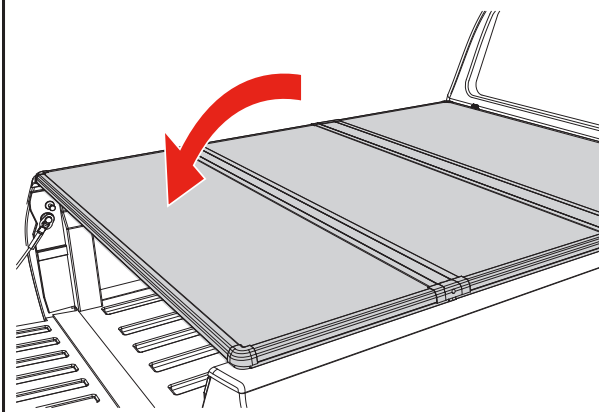

**10** Adjustments and tightening of the latch assemblies are required.

The bed cover latch assemblies and rotary knob come from the factory only partially tightened to allow installation adjustments. Both latches and rotary knob will require adjustment and final tightening. **Only use the hand tools provided, do not use power tools.**

Lower the rear of the bed cover and loosen the screws on both latch assemblies and the rotary knob. Rotate the knob to locate the screws. Adjust the position of each latch so that they engage with the striker brackets, (Fig. 1) . With the latches adjusted, from underneath the cover, use the provided T-20 Torx wrench to tighten the two screws, (Fig. 2) so the latch does not move in the channel. Repeat on the other side.

The cables come routed through the barrel clamps of the rotary knob. Adjust the position of the rotary knob so that the cable from the driver's side latch extends 3/4" - 1" through the barrel clamp for future adjustments if needed. (Fig. 3)

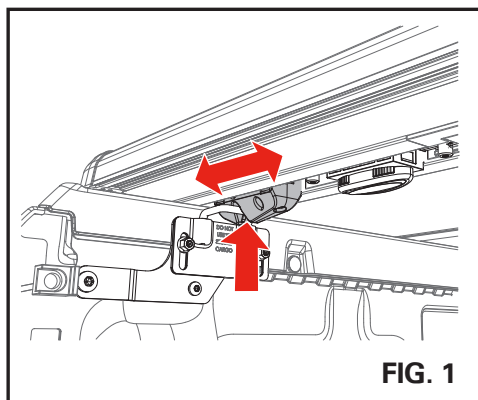

FIG. 1

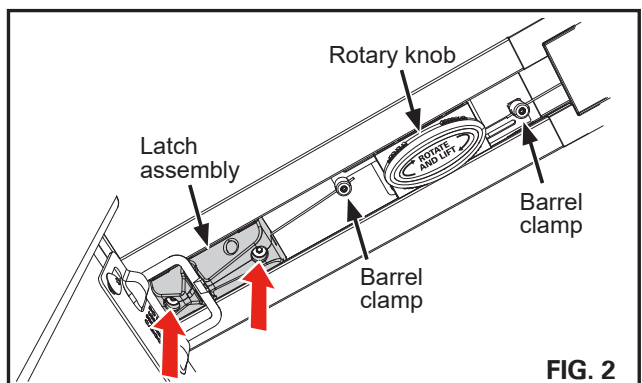

FIG. 2

Rotate the rotary knob until you see the flat head screws. Tighten the two screws using the provided Torx T-20 wrench. (Fig. 3) so the knob does not move in the channel. Repeat on the other side.

Next, ensure that the cables are located through the barrel clamps and tighten the barrel clamp set screws with the provided 2.5mm hex key. Rotate the rotary knob to verify that the latches disengage from the striker brackets. (Fig. 4)

Close the cover, double-check that it is secure and tight to the truck bed by gently lifting the corners to ensure that the mechanisms are engaged. Proceed to step 10 to make the final adjustment.

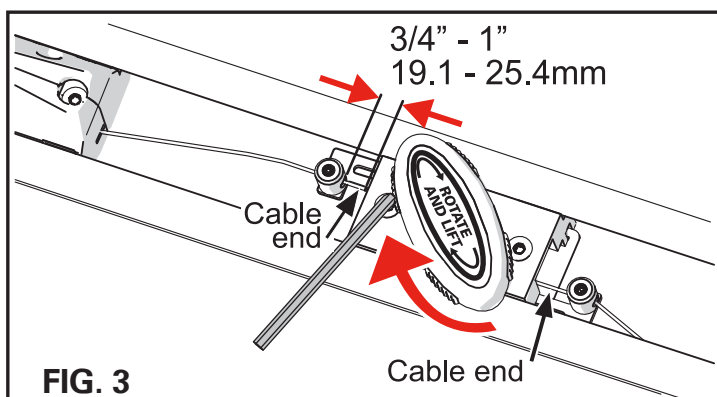

FIG. 3

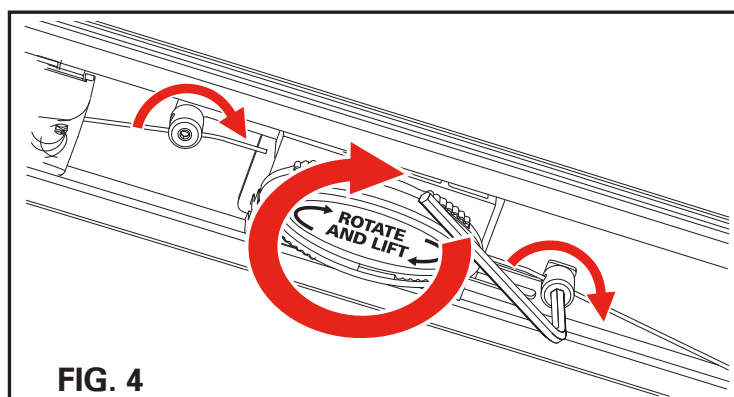
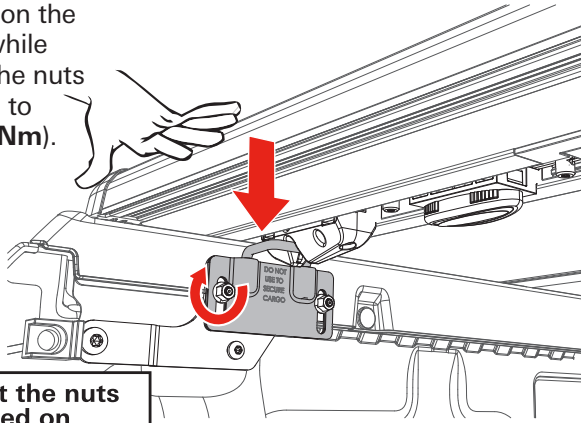

FIG. 4

**11** To make the final adjustment, loosen the striker bracket M6 flange nuts (D), move the striker bracket (B) down by firmly pushing the cover to the truck side rails. Make sure that both sides match and tighten the nuts.



Push down on the bed cover while tightening the nuts (D), (10mm) to **8 ft-lbs (11Nm)**.



Ensure that the nuts are tightened on each side of the truck.

### Opening the cover

Open the cover by twisting the rotary knob and lifting the cover.

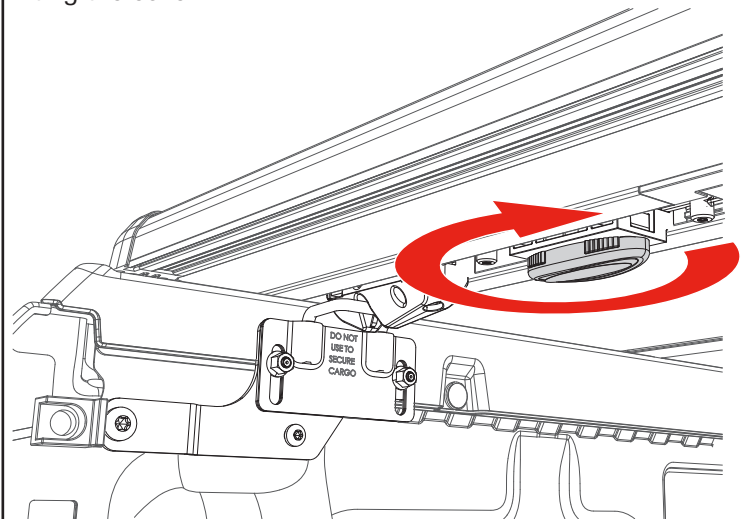

### Securing the cover

**!** To drive with the cover open, fold the cover forward to the cab and fasten **BOTH** straps in the middle section to the front rail. Check that the straps are tight, and pull the strap end if too loose.

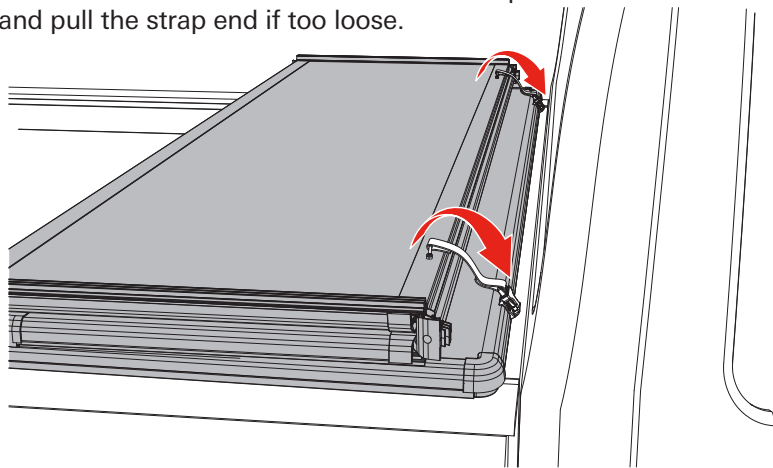
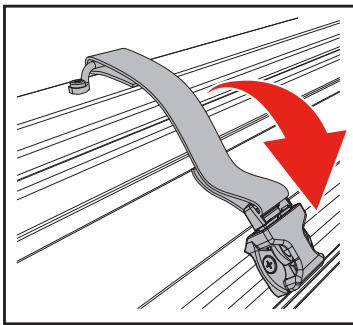

## **!** IMPORTANT

Re-tighten the front/cab clamps and tethers after the first week of driving the vehicle. Also periodically check the clamps and tethers to ensure they are secure.

**Closed/Extended Position** - Bed cover must be completely secured by all four (4) clamps.

**Open/Folded Position** - Bed cover must be completely folded up (all panels) and secured at the cab with the provided buckles straps and with both tethers attached.

Do **NOT** drive with the bed cover in a partially open position.



Do **NOT** allow the vehicle to be towed backwards without first removing the cover from the vehicle.



Remove any snow or foreign matter before folding the bed cover.

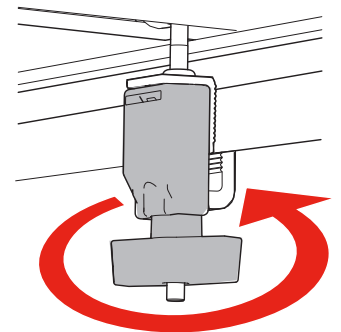

# REPLACEMENT PARTS

Replacement parts can be ordered online at [extang.com/replacement-parts](http://extang.com/replacement-parts) or you can contact our Customer Service Department for assistance. When ordering, xxx represents the 3 digit suffix, as referenced on the sales receipt or vehicle application list.

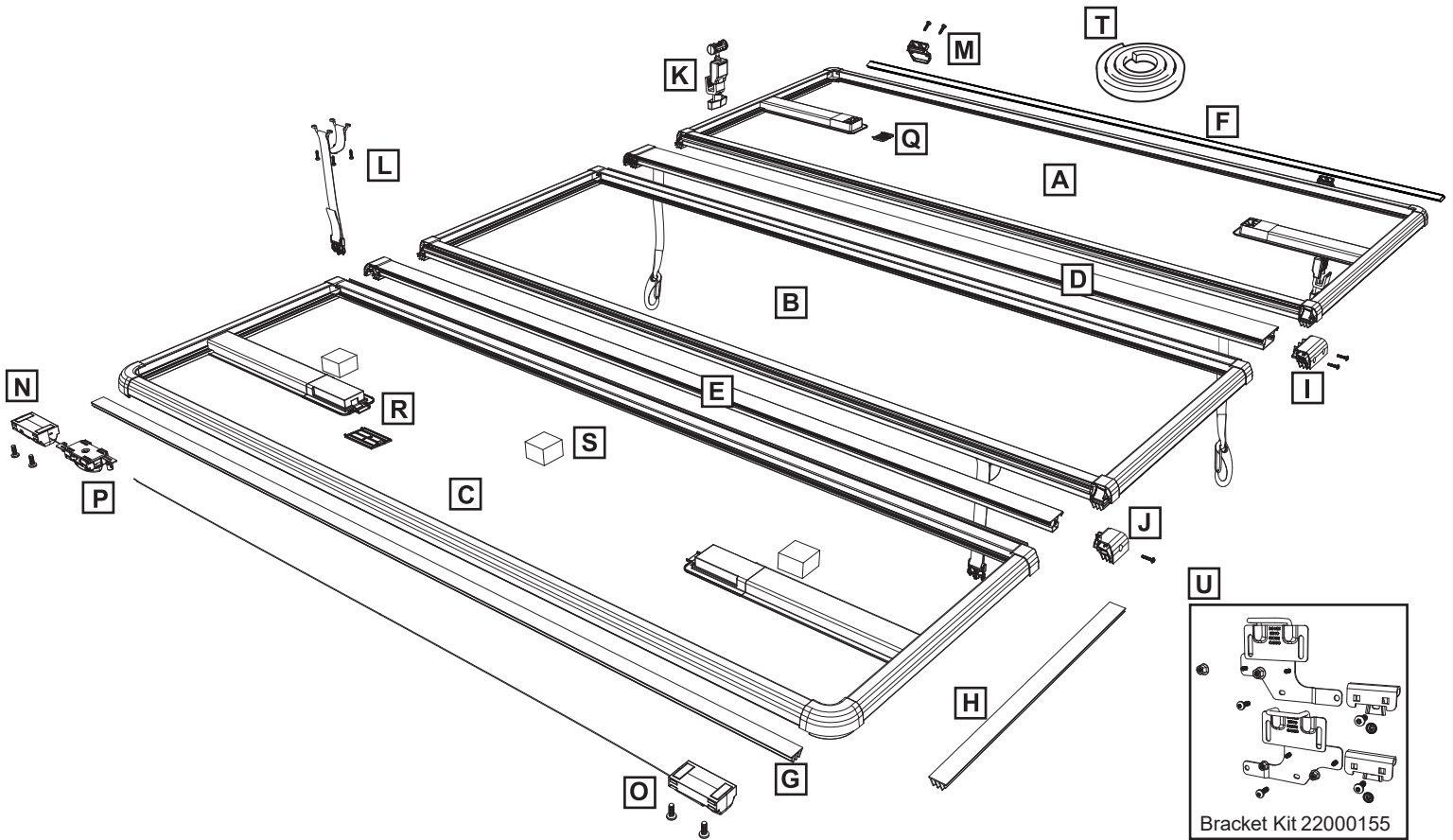

Call Out	Title	Part Number	Description	Qty
A	Cab Panel	88xxx-60	Cab panel assembly	1
B	Mid Panel	88xxx-61	Mid panel assembly	1
C	Tail Panel	88xxx-62	Tail panel assembly	1
D	Cab Hinge	88xxx-63	Cab hinge assembly	1
E	Tail Hinge	88xxx-64	Tail hinge assembly	1
F	Cab Seal	32002112	Single length seal (68"), hollow seal, cut to fit	1
G	Tailgate Seal	32562569	Seal - tail 2 fin with adhesive	1
H	Side Seal	32000685	Single length (68") Side Seal, cut to fit	1
I	Cab Hinge Cap Kit	31830010	Cab hinge cap & fasteners	1
J	Tail Hinge Cap Kit	31830020	Tail hinge cap & fasteners	1
K	Front (Cab) Clamp	1288	Front clamp assembly	1
L	Tie Down Kit	31831010	Male buckle Strap & fasteners	1
M	Cab Buckle Kit	31830002	Female buckle & fasteners	1
N	Latch Assembly, Driver	28900100	Autolatch assembly for the driver side	1
O	Latch Assembly, Passenger	28900101	Autolatch assembly for the passenger side	1
P	Rotary Release Assembly	28900102	Rotary assembly	1
Q	Latch Pocket Cover, Cab	35830102	Plastic cover for the latch pocket on the cab panel	1
R	Latch Pocket Cover, Tail	35880002	Plastic cover for the latch pocket on the cab panel	1
S	Spacer Pad	32622500	Foam adhesive backed pad	1
T	Bulkhead Seal Kit	23000011	Adhesive backed seal with instructions.	1
U	Bracket Kit	22000155	Complete kit for rear (tailgate) and front (cab) brackets.	1

# LIMITED WARRANTY

## WARRANTY COVERAGE

This truck bed cover is warranted against defects in materials or workmanship as follows. This warranty is void if the product has been damaged in an accident, or due to neglect, unforeseeable use, improper installation, improper servicing, or other cause not arising out of defects in material or workmanship.

**The truck bed cover carries a limited warranty for five (5) years from the original date of purchase, subject to the terms below.**

## WARRANTY IS NOT TRANSFERABLE

The warranty is to the initial owner purchasing the truck bed cover and it is not transferrable to a subsequent end user. Proof of purchase may be required to enforce these warranty rights.

## WARRANTY CONDITIONS

Failure to follow these care and use instructions will void the warranty.

- Clean with mild automotive soap and water only.
- Cover must be secured at all points when vehicle is in motion. When not fully extended, cover must be completely folded up and secured at the cab with the provided buckle straps and tethers attached. Do NOT drive with the bed cover in a partially open position.
- Check all clamps and retention mechanisms for tightness after a week of driving following installation (or re-installation) of the cover and periodically thereafter.
- Before opening, cover must be free of all foreign materials including snow and ice.
- Do NOT tow your vehicle from the rear with the cover on your vehicle. If towing from the rear is required, the cover MUST be removed from the vehicle and properly stored.

## WARRANTY PERFORMANCE

If all warranty conditions are met, a defective truck bed cover or hardware component will either be repaired or replaced (at our option). We reserve the right, for any warranty, to substitute a newer model or bed cover having similar form and function, to offer a warranty discount on an entire replacement system, and/or provide remedies other than those mentioned in this document.

## WARRANTY PROCESS

A Return Authorization number must be obtained from our Customer Service Department prior to returning any product. We may require the original item to be returned postage prepaid for final determination. Shipping charges will apply for any repair or replacement. Other than postage or shipping charges, no charge will be made for repair or replacement under this warranty.

This warranty gives you specific legal rights. As an owner, you may also have additional rights and remedies under the laws of your state.

## WARRANTY REGISTRATION

Warranty registration must be on file and/or proof of original purchase (detailed and dated receipt) required for warranty to be effective.

Register online at <https://realtruck.com/extang-warranty>

**REGISTER  
YOUR  
WARRANTY  
ONLINE**



**SOMETHING DAMAGED? MISSING PARTS?**

---

**CALL US FIRST**  
**800-877-2588**

**WE CAN HELP YOU QUICKLY AND EASILY OVER THE PHONE**

---

Experienced Customer Service staff are available  
to answer all your truck bed cover questions

**CUSTOMER SERVICE HOURS**

**8:30 a.m. TO 6:00 p.m. EST, MONDAY - FRIDAY**

Truck bed cover model: \_\_\_\_\_

Purchase date: \_\_\_\_\_

Lot code: \_\_\_\_\_

*Lot code can be found on the underside of cover.*