



Installation Instructions EZ-Fold Tonneau



No Drilling in Truck Bed Required

Vehicle Application:

- Nissan Frontier 4.9' Bed 2005 – Current
- Nissan Frontier 6' Bed 2005 – Current
- Part Number: 16146
- Part Number: 16147

www.Bestop.com - We're here to help! Visit our web site and click on ["Ask a Question"](#). Click here for more [Truck Accessories by Bestop](#).

INSTALLATION TIME	SKILL LEVEL
 Less than 15 minutes	<div style="display: flex; justify-content: space-around;"> 1 2 3 4 </div> 1 - Easy

TOOLS	
 Safety Glasses	 Power Drill 5/16" Socket



Installation Tips

Before you begin installing this assembly, read all instructions thoroughly.

Check and secure all clamps to bed frame as indicated in the installation instructions before operating your vehicle.

Tonneau cover clamps must be securely attached prior to vehicle operation.

Secure retaining straps when cover is in open position.



CAUTION

Safety glasses should be worn at all times while installing this product.



WARNING

The buckle of each retaining strap and both clamps must be fastened securely to avoid damage to personal property or possible personal injury.

If the vehicle has an Over-the-Rail Bedliner, use a certified installer to perform the initial installation. Modifications to the Bedliner may be required.

EZ-Fold Tonneau Installation Instructions

Parts List

Bow Mount, Part Number 728600, Qty - 8



Tonneau Cover, Qty - 1

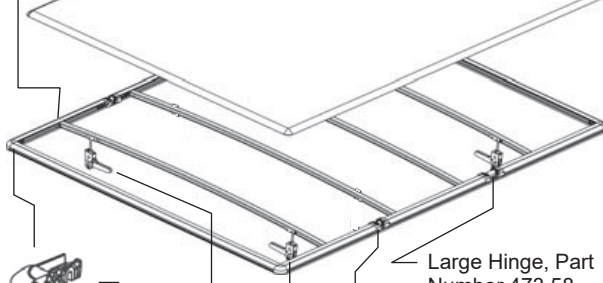

Corner, Part Number 475.36, Qty - 2



Large Hinge, Part Number 473.58, Qty - 2



Small Hinge, Part Number 473.59, Qty - 2



Left Clamp, Part Number 728620, Qty - 2



#10 x 5/8" Truss Head Screw, Part Number 728670, Qty - 16



Outer Clamp, Part Number 514.38, Qty - 4



Tapping Plate, Part Number 514.37, Qty - 4



Right Clamp, Part Number 728625, Qty - 2



#10 Self Drilling Screw, Part Number 514.35, Qty - 8

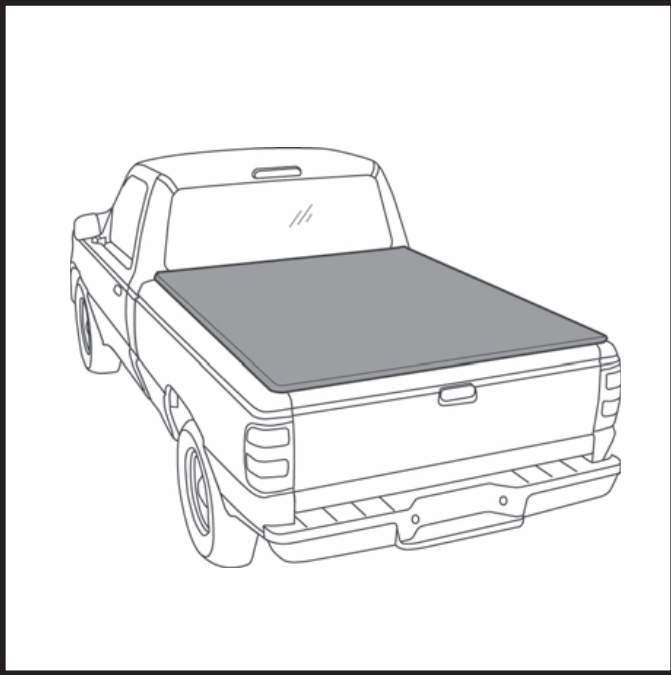

2 Place Tonneau on Bed

Place the Tonneau on the vehicle with the retaining straps facing up. Align the outside edge of the front rail with the outside edge of the bed. Center the Tonneau from side to side.

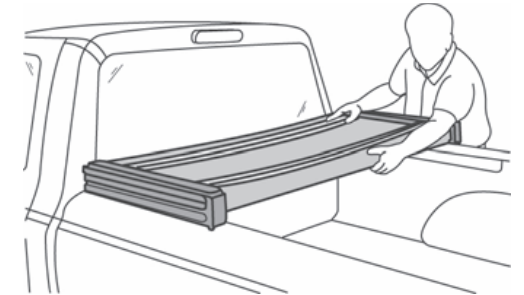

1 Remove EZ-Fold Tonneau from Box

Take fully assembled EZ-Fold Tonneau out of box and unfold.



Trucks with Track System Only

3 Assemble Outer Clamp to Tapping Plate

Use the #10 Self Drilling Screws and a drill to start the screws through the Outer Clamps into the Tapping Plates.

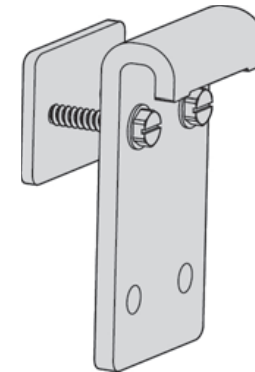

EZ-Fold Tonneau Installation Instructions

Trucks with Track System Only

4 Position Outer Clamp Assemblies

Remove the track end caps. Slide one (1) of the Outer Clamp Assemblies into the track on each side. Place them approximately 10" from the front end of the track system. Replace the end caps.

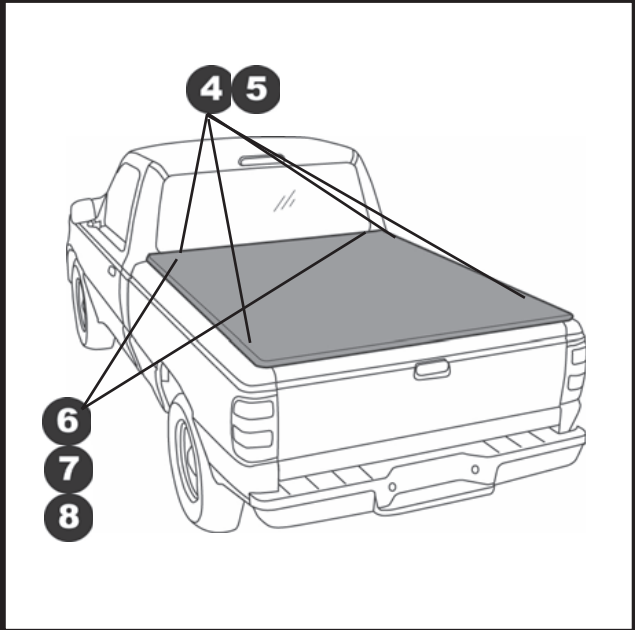
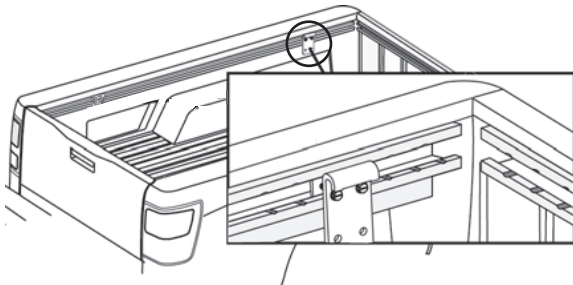

7 Position Front Clamp

Slide the clamp to the end of the bow. Position the notched section of the saddle under the inner lip of the truck bed.

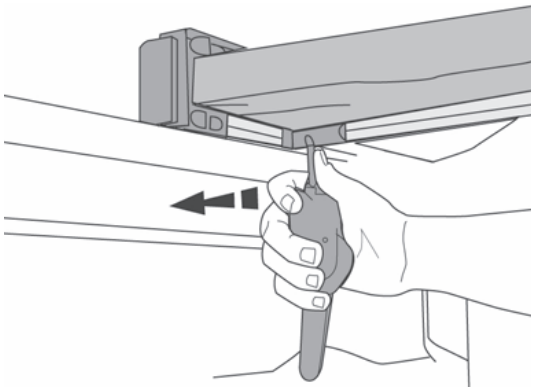

Trucks with Track System Only

5 Secure Outer Clamps

Align the Outer Clamp with the tonneau latches and make sure that they are centered with each other. Tighten the screws.

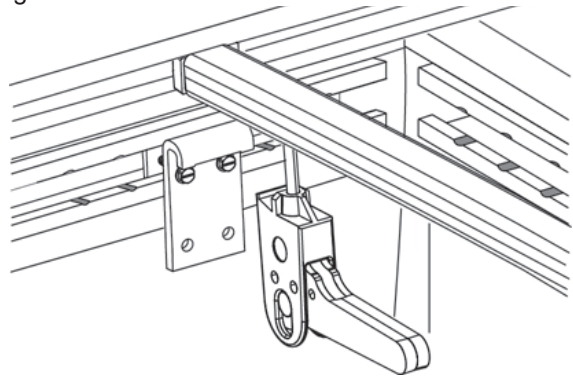

6 Release Front Clamp

On the driver's side, reach under the Tonneau and rotate the front clamp down from the storage position. Push the top saddle part of the clamp down and adjust the clamp by rotating it clockwise to loosen or counter-clockwise to tighten.

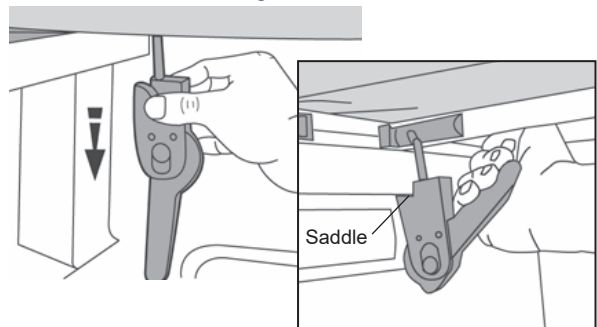

8 Secure Front Clamp

Pull the handle up to secure the clamp. Repeat Steps 6 – 8 on the passenger side.

NOTE Make sure clamps are secure before operating vehicle.

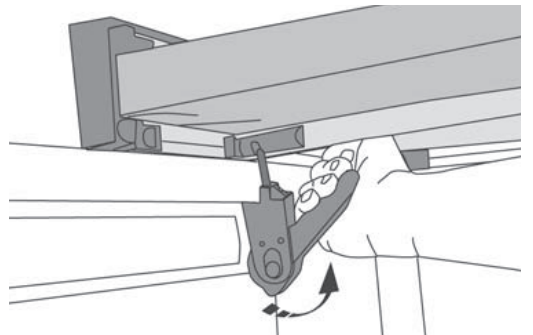

EZ-Fold Tonneau Installation Instructions

9 Unhook the Retaining Straps

Unhook the retaining straps – one per strap.

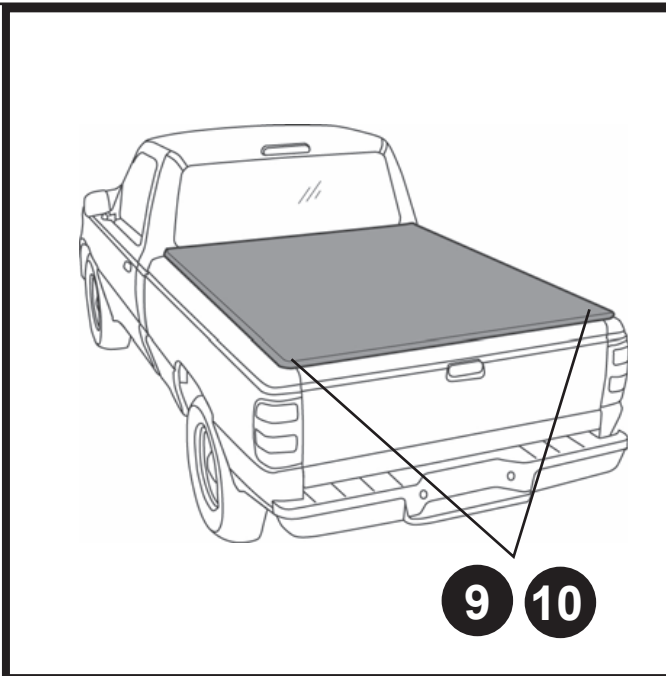
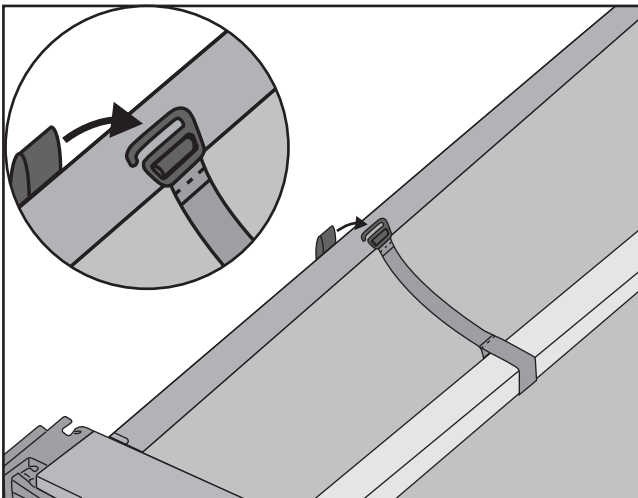

Driving with the Tonneau Open Release Rear Clamps

Pull down on the handle to release the rear clamp on the driver's side.

Push down on the saddle to release it from the inner lip of the truck bed.

Slide clamp toward inside of bed.

Place clamp in horizontal storage position.

Repeat on the passenger side.

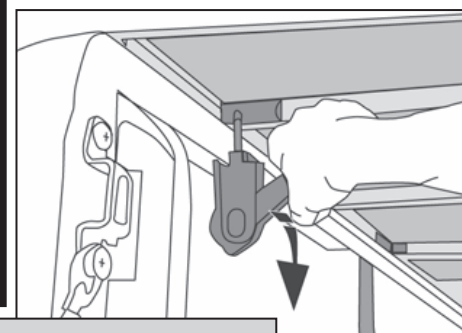

10 Secure Tonneau

Lower the tailgate and unfold the Tonneau to cover the bed. Repeat steps 7-8 to secure rear clamps.

NOTE: If clamp bracket from step 10 was installed, be sure clamp falls in the middle of the clamp. If it does not, move the tonneau either forward or rearward slightly.

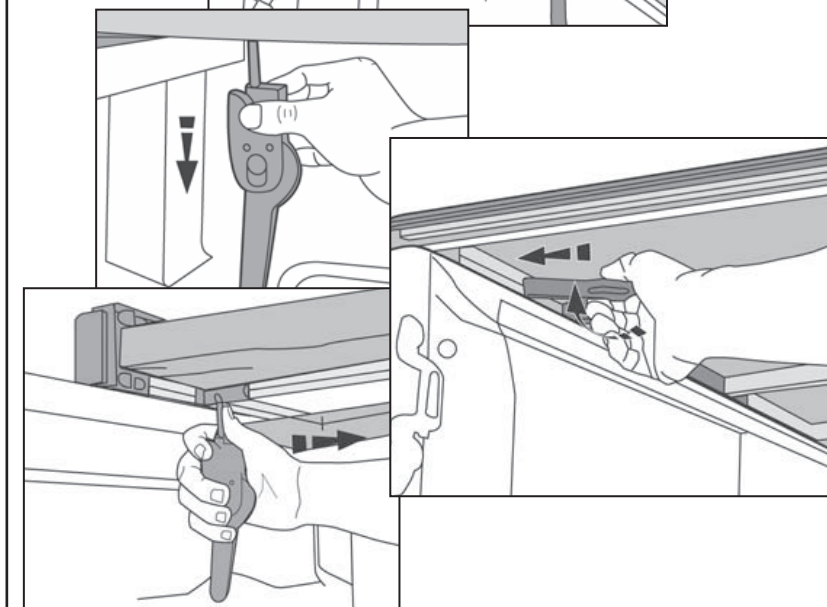
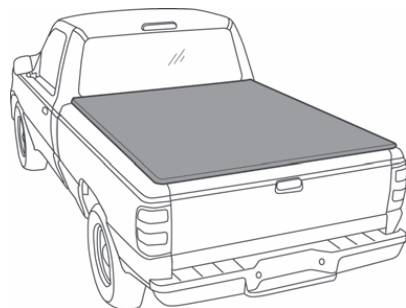
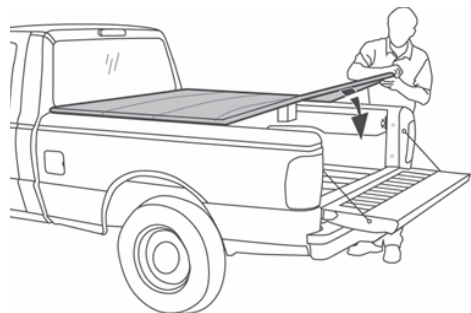

EZ-Fold Tonneau Installation Instructions

11 Driving with the Tonneau Open Fold Tonneau Forward

Fold the Tonneau toward the front of the vehicle.

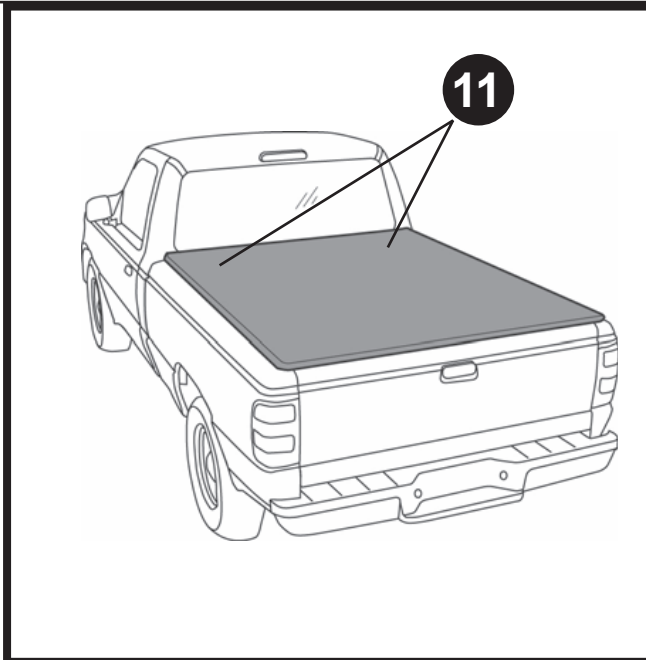
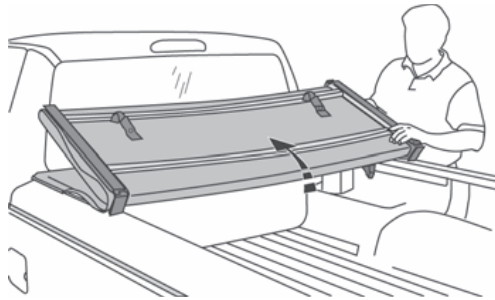

WARNING

The retaining strap on both sides must be fastened securely to avoid damage to property or possible personal injury.

12 Driving with the Tonneau Open Secure Retaining Straps

Hook one of the retaining straps to the front of the Tonneau. (Both sides)

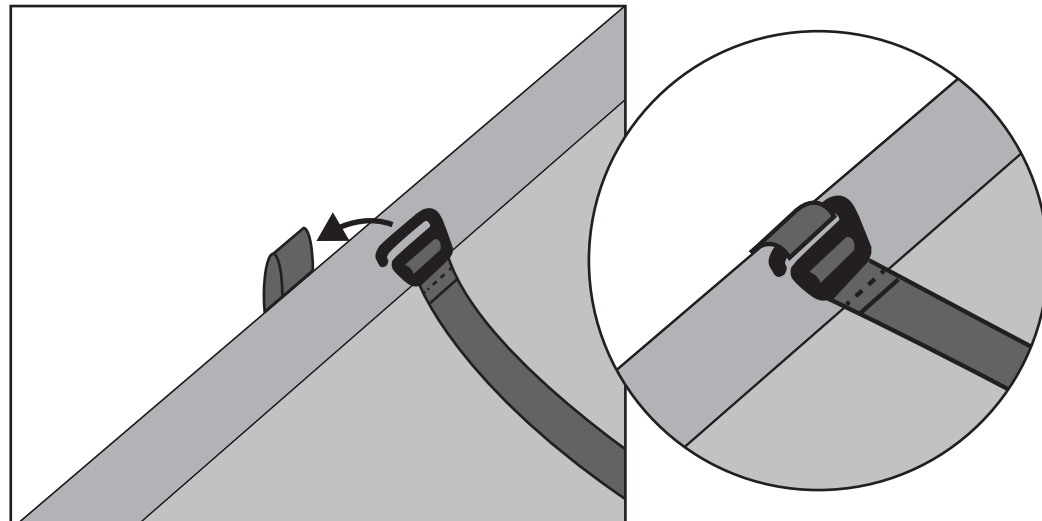



Care and Maintenance of your Bestop Product

Your Bestop product is made of the finest materials available. To keep it looking new and for the maximum possible wear, it will need periodic cleaning and maintenance.

Fabric: The fabric should be washed often using soap, warm water and a soft bristle brush. Rinse with clear water to remove all traces of soap. Bestop recommends using Bestop Cleaner (part no. 11201-00) and Bestop Protectant (part no. 11202-00) for Vinyl fabric and Bestop Twill Protectant (part no. 11207-00) for Twill fabric. Bestop Cleaner and Bestop protectant are specially formulated to provide a total cleaning and protection system. Bestop Cleaner safely removes the toughest stains, will not harm vehicle finishes, is biodegradable and environmentally friendly. Bestop Protectant protects against UV-fading, cracking and hardening, and repels dust, grease, dirt and mildew.

Windows: Keep windows clean to avoid scratching. DO NOT use a brush on the windows! Wash with a water-soaked cloth or sponge and a mild dishwashing detergent. Bestop recommends Bestop Vinyl Window Cleaner (part no. 11203-00), which safely cleans and protects vinyl windows and helps prevent UV damage. NEVER WIPE THE WINDOWS WHEN THEY ARE DRY. Be careful when cleaning snow or frost from the vinyl windows since they are easily scratched and may crack at low temperatures. DO NOT roll the sides or rear window in cold weather. The windows become stiff and will crack. Cracks caused by misuse in cold temperatures are not covered under warranty.

Water: Seeping through at the seams may be stopped by applying 3-M Scotchgard® on the inside of the seams.

Snaps: Keep snaps cleaned and lubricated with silicone to help prevent snaps from sticking to the studs. If a snap does become stuck to a stud, use a screwdriver and GENTLY pry apart to prevent permanent damage to the snap or the top fabric.

Zippers: Keeping zippers cleaned and lubricated with Bestop's Zipper Cleaner (part no. 11206-00) will help prevent damage and keep the zippers in smooth working condition. If a zipper opens behind the slider, the slider may have been spread apart. This problem can usually be repaired by using an ordinary pair of pliers to bring the sides back into parallel. Return slider to the end of the zipper in the normal Open position. Squeeze lightly at first and test the zipper. If the zipper continues to remain open squeeze more firmly with the pliers and try the zipper again. Repeat this procedure until the zipper operates correctly.

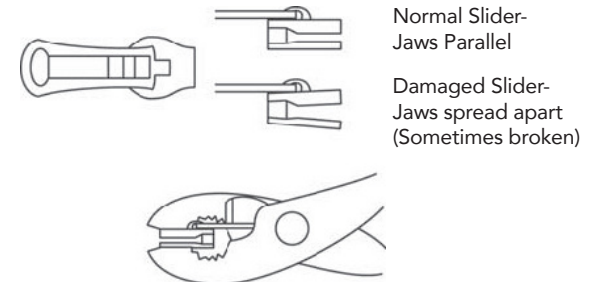

For Bestop Warranty Information, Please go to;
<https://www.bestop.com/help/warranty-information/>

