

GT
MOMENTUM

advanced FLOW engineering

Momentum GT Air Intake System

Instruction Manual P/N: 50-70131D / 50-70131R

Make: TOYOTA

Model: Tacoma TRD Pro

Year: 2024-2026

Engine: L4-2.4L(t)

Make: TOYOTA

Model: 4Runner TRD Pro

Year: 2025-2026

Engine: L4-2.4L(t)

Only fits TRD Pro submodel.



- Please read the entire instruction manual before proceeding.
- Ensure all components listed are present.
- If you are missing any of the components, call customer support at 951-493-7185.
- Ensure you have all necessary tools before proceeding.
- Do not attempt to work on your vehicle when the engine is hot.
- Retain factory parts for future use.

Label	Qty.	Description	Part Number
A	1	Air Filter, P5R (For 50-70131R Only)	24-91153
A	1	Air Filter, PDS (For 50-70131D Only)	21-91153
B	1	Tube With MAF Sensor Pad	05-5070131B1
C	1	Housing With Clear Sight Window	05-5070119B2
D	1	Coupler, Silicone Bellow: (2-3/4" x 3"ID) x 3"L (Red)	05-01528R
E	1	Clamp, 048 (2-9/16" - 3-1/2")	03-50007
F	1	Clamp, 044 (2-5/16" - 3-1/4")	03-50019
G	1	Seal, Inlet For Factory scoop (Red)	05-01763R
H	1	Gasket, Inlet Fender	05-01762
J	1	Alcohol Wipes	05-01716
K	2	Screw, Torx: M4 x .7 x 10mm	03-50490
M	1	Cable tie	05-60167

Installation will require the following tools: T20 torx bit or driver, small flat head screwdriver, Phillips screwdriver, 10mm socket or nut driver, 8mm socket or nut driver

Warranty Information available at <https://afepower.com/contact#warranty>

Emissions Disclaimer: This product is not currently CARB exempt and is not available for purchase in California or for use on any vehicle registered with the California Department of Motor Vehicles.

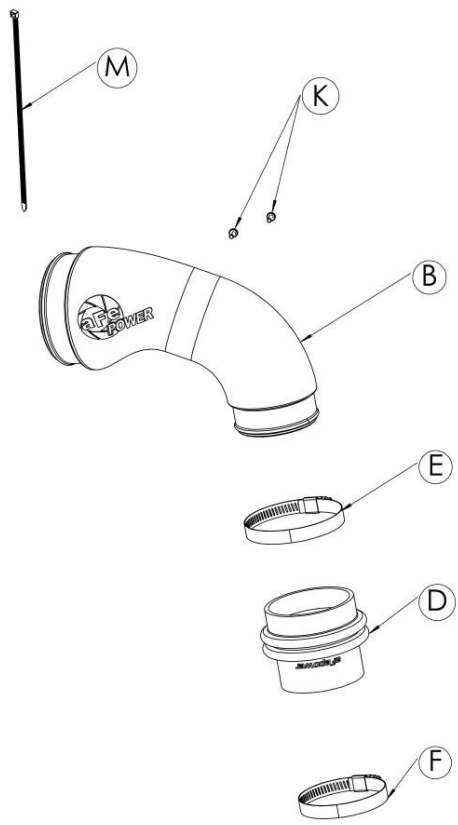
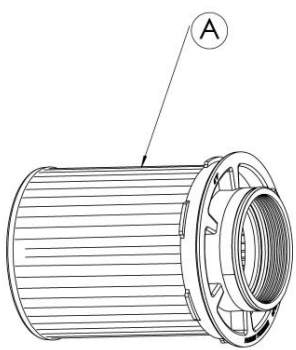
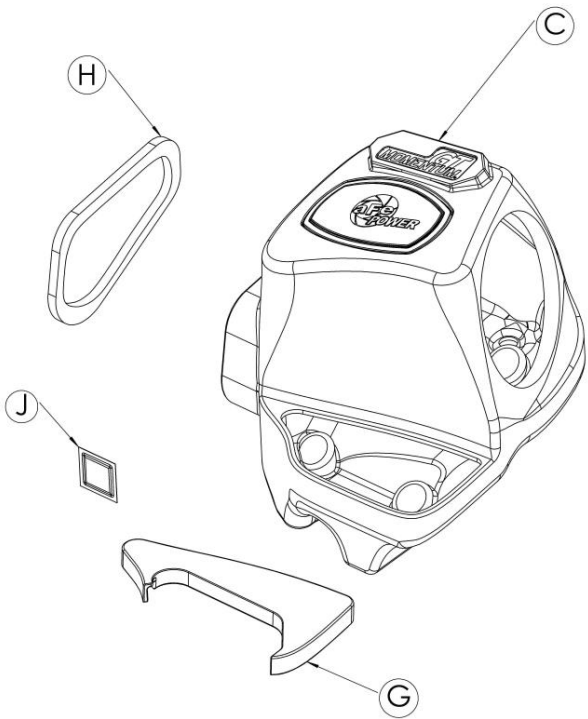



Figure A

Refer to Figure A for Step 1

Step 1: Carefully remove the (4) four push clips securing the factory scoop, by pressing on the center of them then lifting them up. Remove the scoop from the factory airbox and engine bay.



Refer to Figure B for Steps 2-4

Step 2: Disconnect the harness from the Mass Air Flow (MAF) sensor and unclip the factory MAF harness from the factory airbox.

Step 3: Using a 10mm nut driver, loosen the factory intake tube clamp.

Step 4: Lift the factory air intake assembly from the vehicle by firmly pulling on it to get the grommets out of the mounts.

**Figure C****Refer to Figure C for Step 5**

Step 5: Using a T20 bit or driver, remove the MAF sensor from the factory airbox.



Figure D

Refer to Figure D for Step 6

Step 6: Transfer the MAF sensor from the factory airbox to the aFe POWER intake tube and secure it using the provided T20 Torx M4 screws.



Refer to Figure E for Step 7

Step 7: Remove the (3) three grommets from the bottom of the factory airbox.

**Figure F****Refer to Figure F for Steps 8-9**

Step 8: Transfer the factory grommets onto the aFe POWER airbox.

Step 9: Wipe the non-textured surface of the side air inlet of the housing with the provided cleaning wipe to remove any residual mold release. Wait for the alcohol to evaporate, then apply the foam gasket on the surface of the fender inlet.

**Figure G****Refer to Figure G for Steps 10-11**

Step 10: Install the aFe POWER air filter into the housing by firmly pushing it into the housing until the filter tabs lock it into place. Install the clamp onto the filter, but do not tighten at this time.

Step 11: Install the seal onto the scoop inlet.

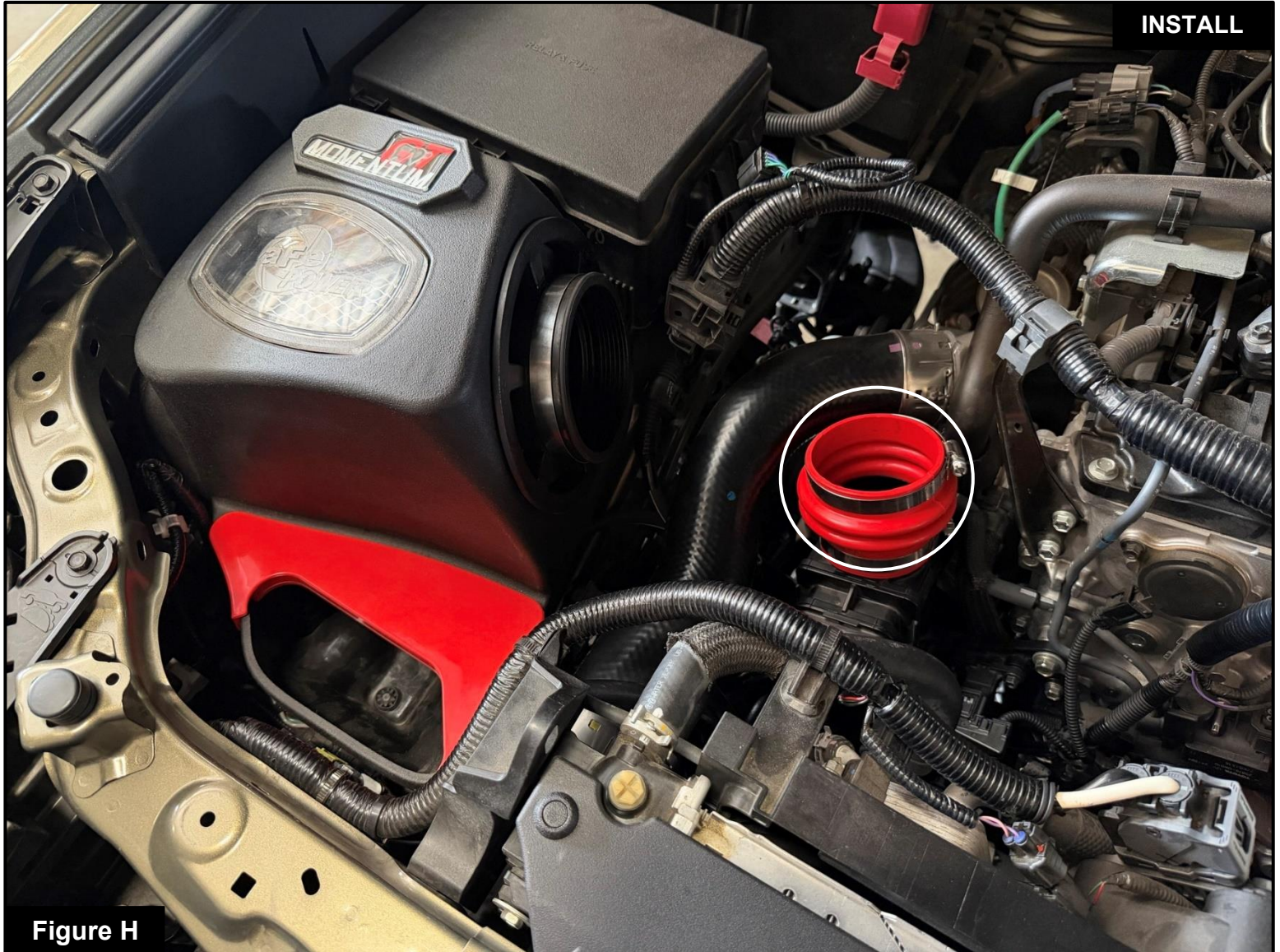

Figure H

Refer to Figure H for Step 12-13

Step 12: Install the aFe POWER air box into the vehicle. Make sure the housing is secured onto the 3 mounting pegs.

Step 13: Loosely install the clamps onto the aFe POWER coupler, and then install the coupler onto the turbo inlet as shown. Do not tighten the clamps at this time.

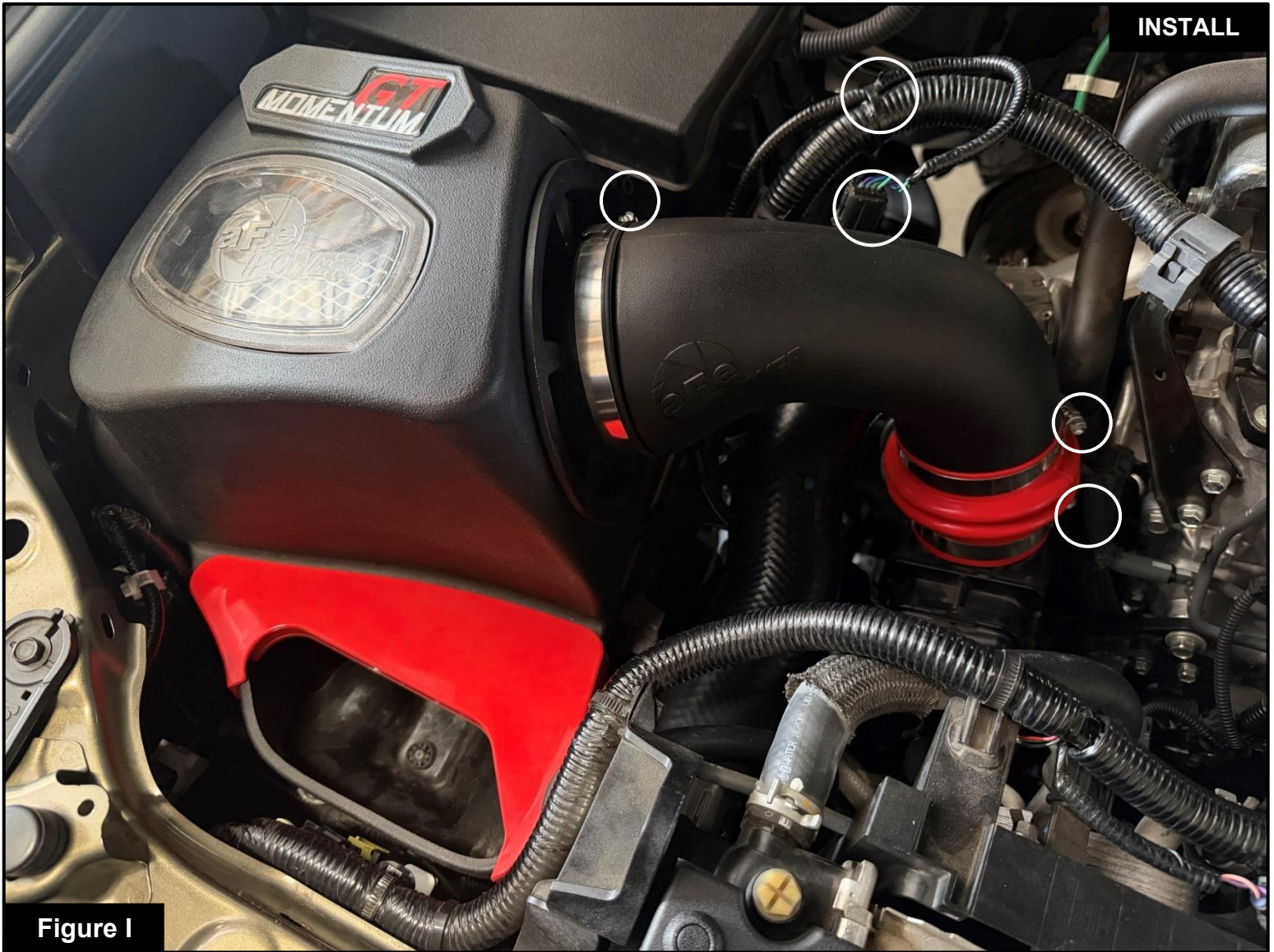

Figure I

Refer to Figure I for Steps 14-15

Step 14: Install the aFe POWER intake tube between the coupler and filter. Align the tube and coupler and then tighten all clamps.

Step 15: Connect the MAF sensor harness to the MAF sensor and secure the harness with the provided cable tie.

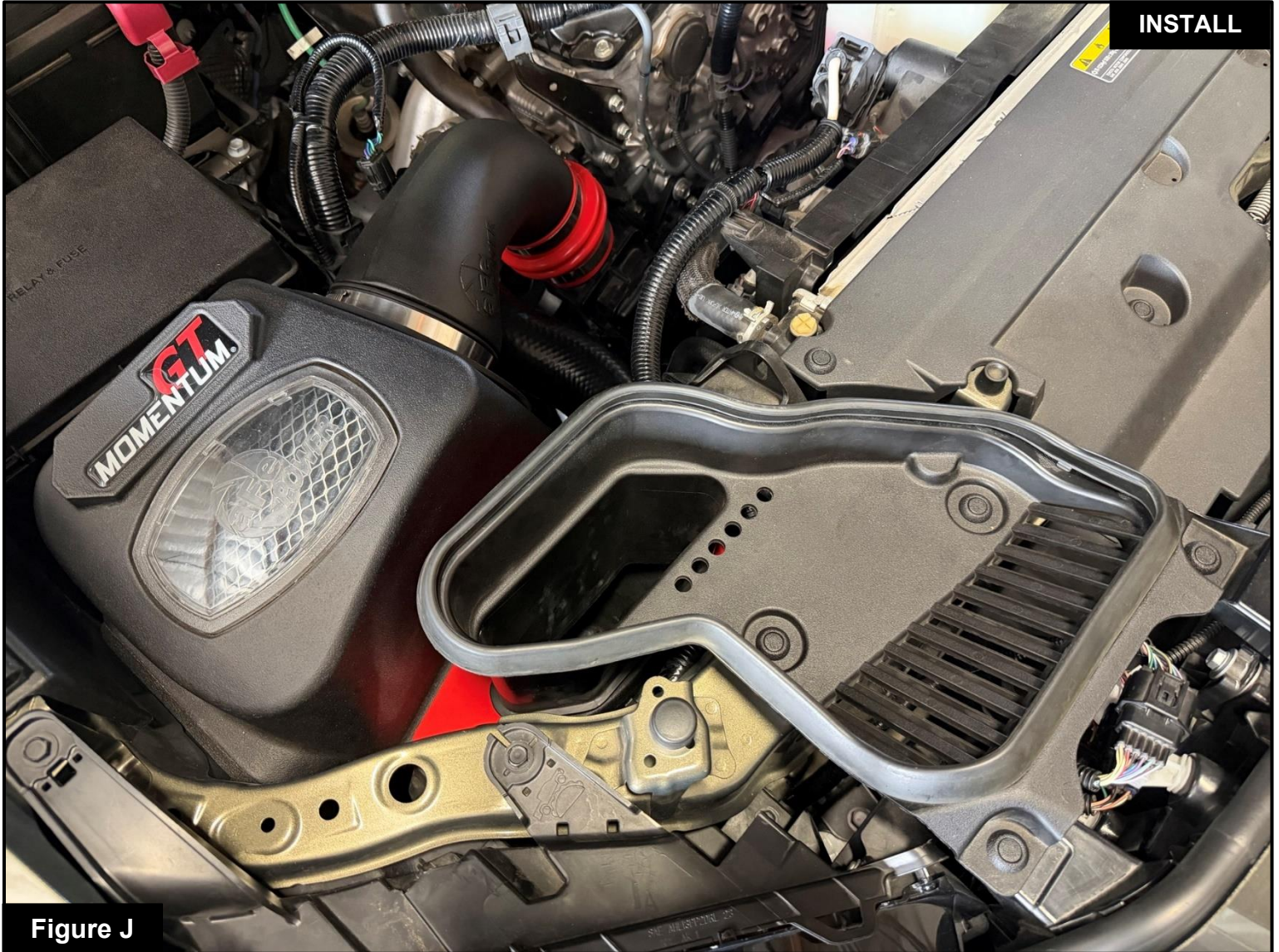

Figure J

Refer to Figure J for Step 16

Step 16: Re-Install the factory scoop and secure it with the factory clips.

Your installation is now complete. Verify all connections and screws are secured. Thank you for choosing aFe POWER!



PAGE LEFT BLANK INTENTIONALLY



PAGE LEFT BLANK INTENTIONALLY



advanced FLOW engineering, Inc.

Corona, CA 92879

<https://afepower.com/contact>