

TOPLIFT PROS™ V2.0 - HARDTOP REMOVAL TOOL AND STORAGE DEVICE

READ ALL INSTRUCTIONS CAREFULLY BEFORE ASSEMBLY THE TOPLIFT PROS™ V2.0 LIFT!

TOPLIFT PROS™ V2.0 LIFT ADJUSTING CHART

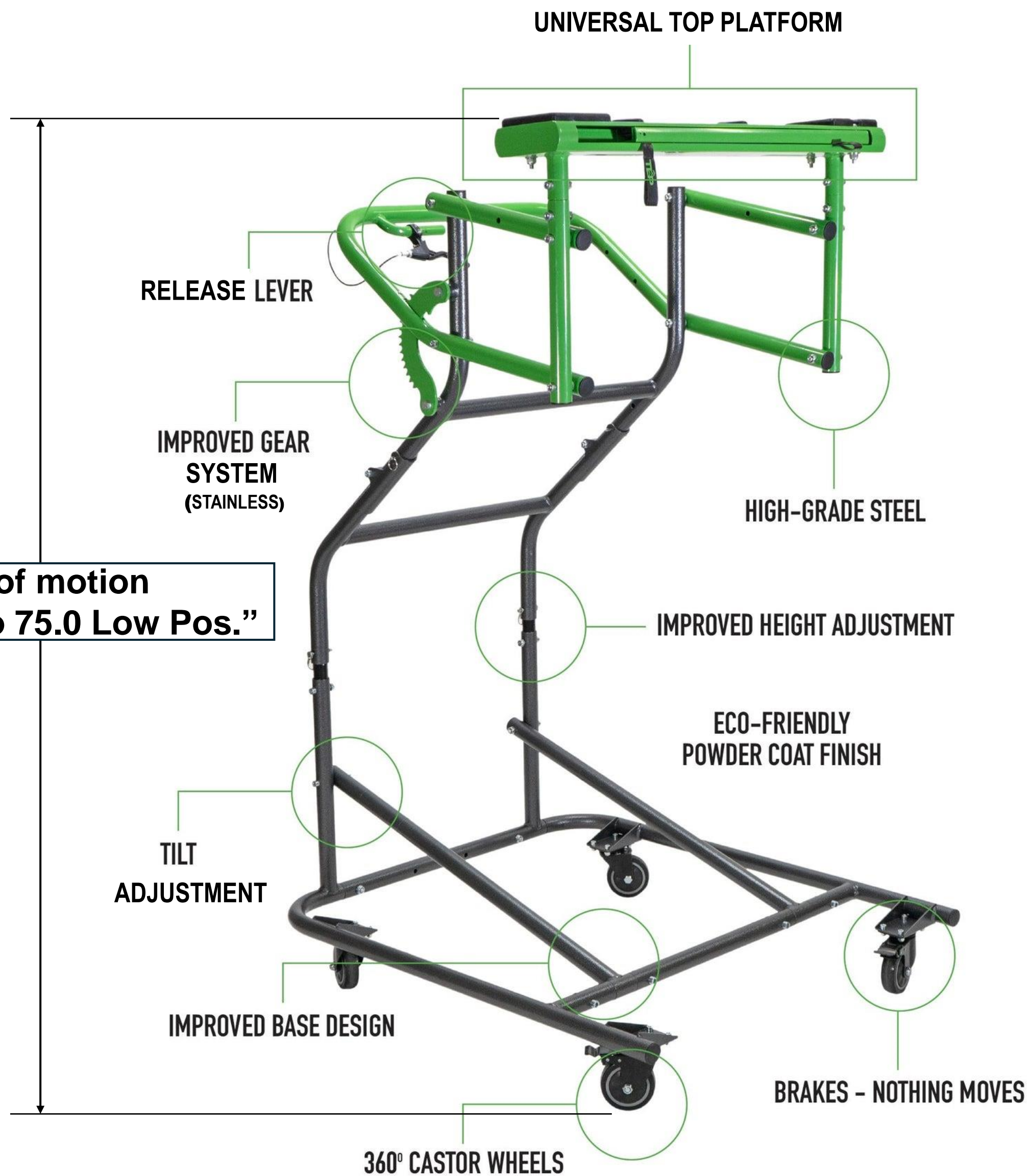

TOP A	BASE B	BASE C	DEVICE HEIGHT	YOUR CLEARANCE
8	X	4	63 1/4	64+
8	6	3	65 7/8	68+
8	5	2	68 1/2	70+
8	4	1	71 1/8	73+
8	3	X	73 3/4	75+
8	2	X	76 1/4	78+

TOP A	BASE B	BASE C	DEVICE HEIGHT	YOUR CLEARANCE
7	6	3	64 3/8	65
7	5	2	67	68
7	4	1	69 5/8	71
7	3	X	72 1/4	74
7	2	X	74 7/8	76

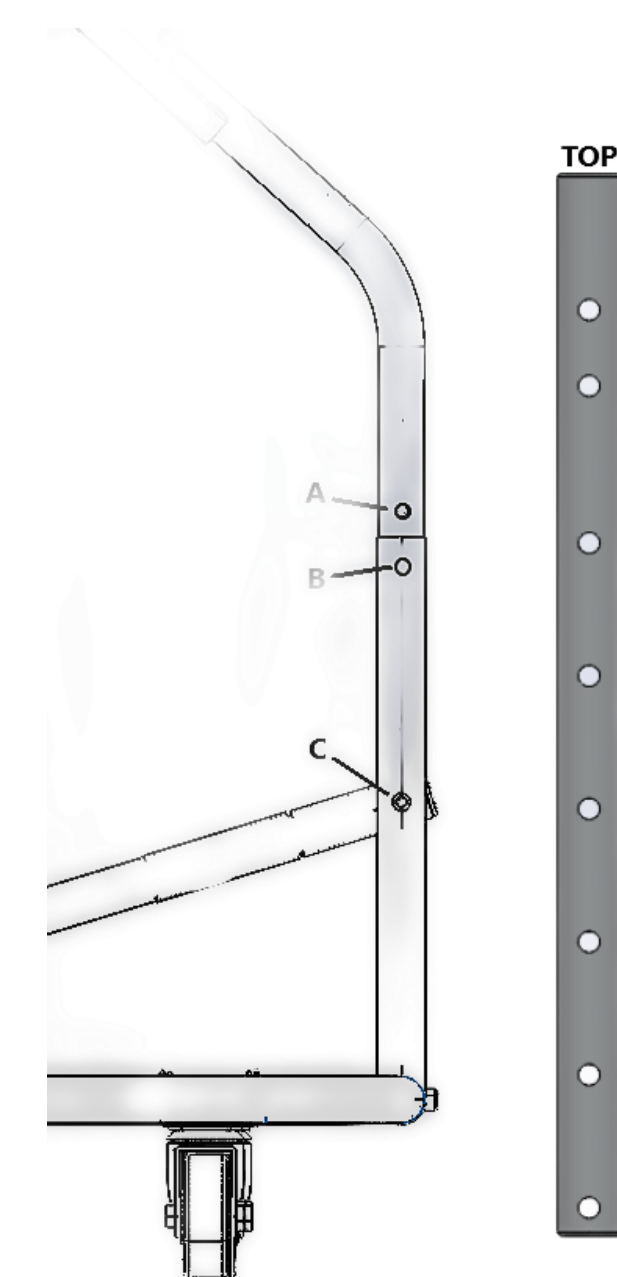

Please see page 3 for Assembly instructions!

ASSEMBLY & USER MANUAL

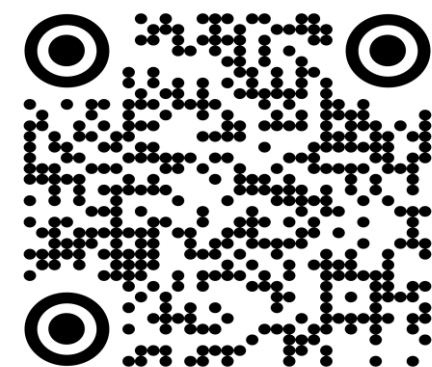

Please scan the QR code to preview our Assembly and User Manual.

TOPLIFT PROS™
 4210 Dow Rd
 Melbourne, Florida 32934
 321.425.4336
info@topliftpros.com

OPERATING INSTRUCTION MANUAL

Place your vehicle on a smooth level ground surface prior to removing your hardtop. You will need a Torx or Allen wrench tool according to your vehicle model.

INSTRUCTIONS FOR REMOVING YOUR HARDTOP!

- Remove ALL fasteners above the driver and passenger areas that hold the panels, then remove the panels.
- Open the cargo door, lift the rear glass & remove the hardtop fasteners on both sides in the cargo area.
- Detach the Electrical & Wiper cleaner connections that are attached to the Hardtop.
- **READY!** Now roll your TopLift Pro into the cargo area with the Handle raised and the Top Platform lowered. The Top Platform should be approx. one inch or so under the rubber gasket, if necessary, reposition the adjustable Inserts as needed.
- Please review the CHART on page one to assist you with setting the right height of the TopLift Pro for your vehicle.
- In two locations, front (2 Door) or rear (4 Door), lift slightly up on the hardtop to make sure it is not held down by something, or it's stuck to the body.
- Now you can position your TopLift Pro into place. Press on the handle to raise the Top Platform so it makes contact to the underside of the hardtop.
- Next, go ahead and lift your hard top to clear the body of the vehicle (approx. 0.5 inches), at this point there is no need to pull the lever to perform this operation. Make sure you leave the rear-glass open.
- **NOTE:** If your top is dipping forward a bit, the insulation material could have caused this, or if you have a top rack installed, the position of the top rack.
- You can adjust the hardtop by turning your TILT ADJUSTMENT to level out the hardtop AFTER YOU HAVE OPENED AND POSITIONED THE SUPPORT ARMS.
- Lift the hardtop just enough to clear the rear gate and spare tire area as you roll the TopLift Pro out away from the vehicle. Always move the TopLift Pro by pulling on the HANDLE or the Main Legs in the rear.
- Swing both SUPPORT ARMS out to stabilize the front portion of the hardtop.
- You can also raise each of the SUPPORT ARM Adjustable FEET, to raise the front even more.
- Simply store your hardtop on the TopLift Pro as you can locate your hardtop over the hood of your vehicle.
- You can store your extra Panels on the rear portion of the hardtop.

NEVER PULL UPON THE LEVER AFTER RAISING WITHOUT APPLYING YOUR BODY WEIGHT ONTO THE HANDLE!

INSTRUCTIONS FOR REINSTALLING YOUR HARDTOP!

- Ready to reinstall your hardtop? Line your hardtop over your vehicle body, so the guide pins that are located on the bottom of the hardtop match the holes in the main vehicle body.
- Apply your body weight to the HANDLE, which will allow you to release the Pawl from the GEAR.
- Pull in on the lever while firmly applying weight on the Handle and then lower the hardtop in small increments while lining up the guide pins in the hardtop to the holes in the vehicle body.
- Once your hardtop is sitting on your vehicle body, you are successful in reinstalling your hardtop. You can now lower the top platform of the TopLift Pro and roll it out of the vehicle.
- Be sure to re-plug your Electrical & Wiper connections back in; and then reinstall and tighten ALL the hardtop bolts and the Freedom Panels.

DO NOT PUSH ON THE HARDTOP ITSELF WHEN MOVING THE TOPLIFT PRO. YOU MAY LOWER YOUR HARDTOP AS NEEDED TO MOVE IT, ESPECIALLY ON LIFTED VEHICLES.

DO NOT EXCEED THE RECOMMENDED WEIGHT REQUIREMENTS OF THE TOPLIFT PRO, ESPECIALLY WHEN YOU HAVE A RACK SYSTEM INSTALLED ON YOUR HARDTOP. THIS IS THE RESPONSIBILITY OF THE VEHICLE OWNER TO CONTROL, AND TOPLIFT PROS WILL NOT BE RESPONSIBLE FOR ANY OCCURRENCES RELATED TO UNSAFE USE, OR STORAGE.

TOPLIFT PROS™
4210 Dow Rd
Melbourne, Florida 32934
321.425.4336
info@topliftpros.com

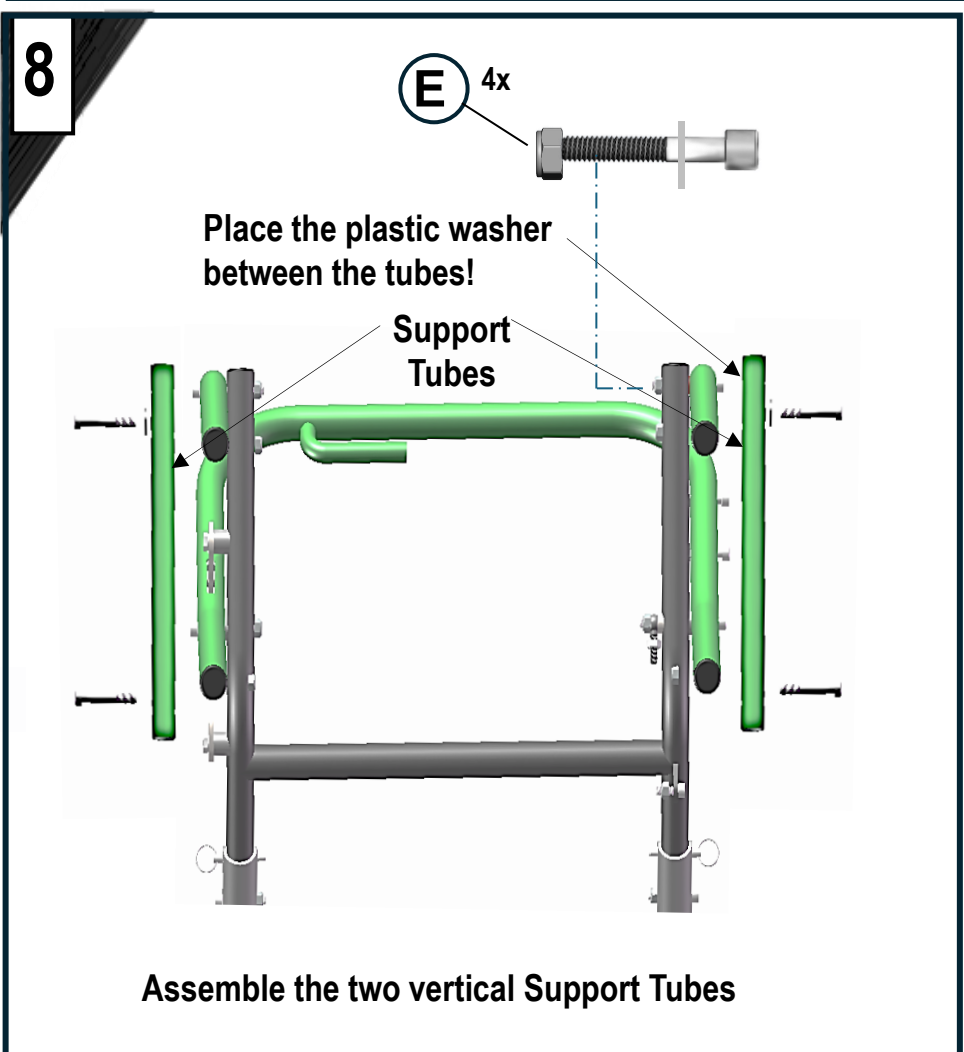
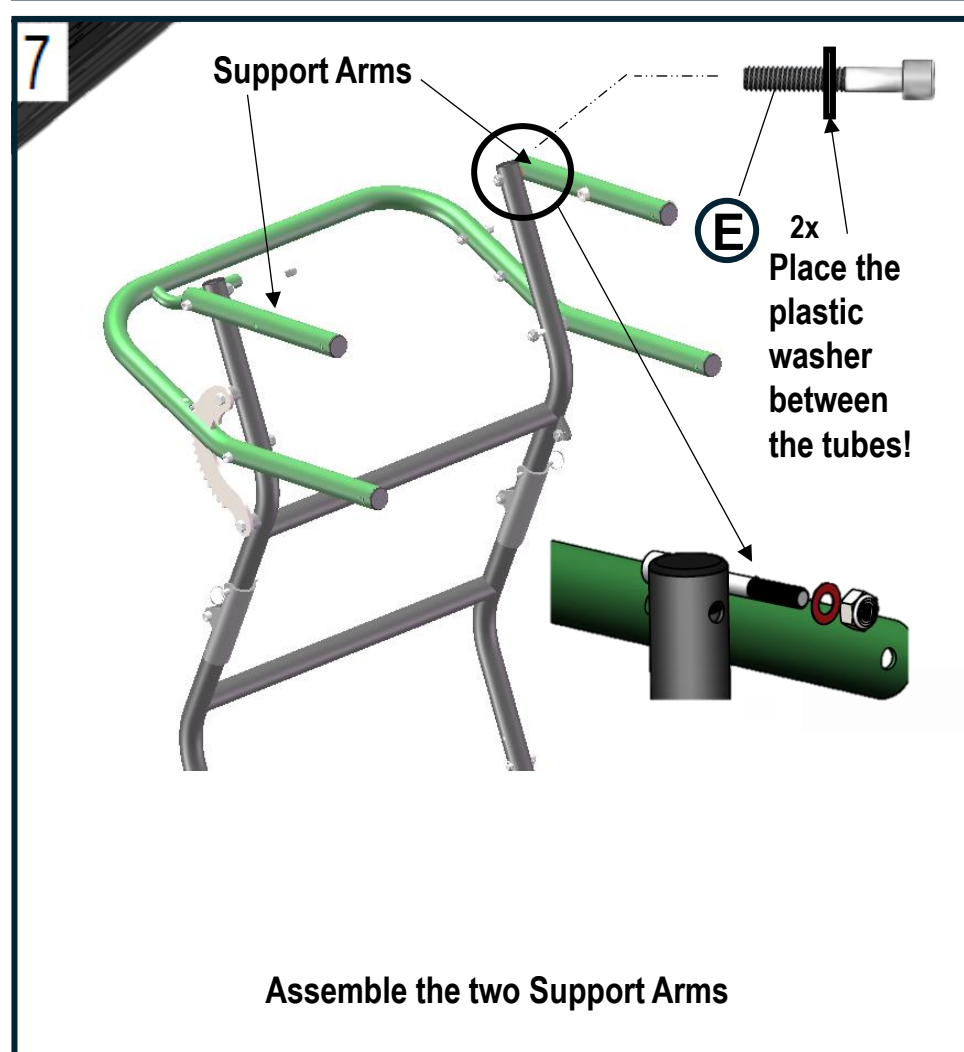
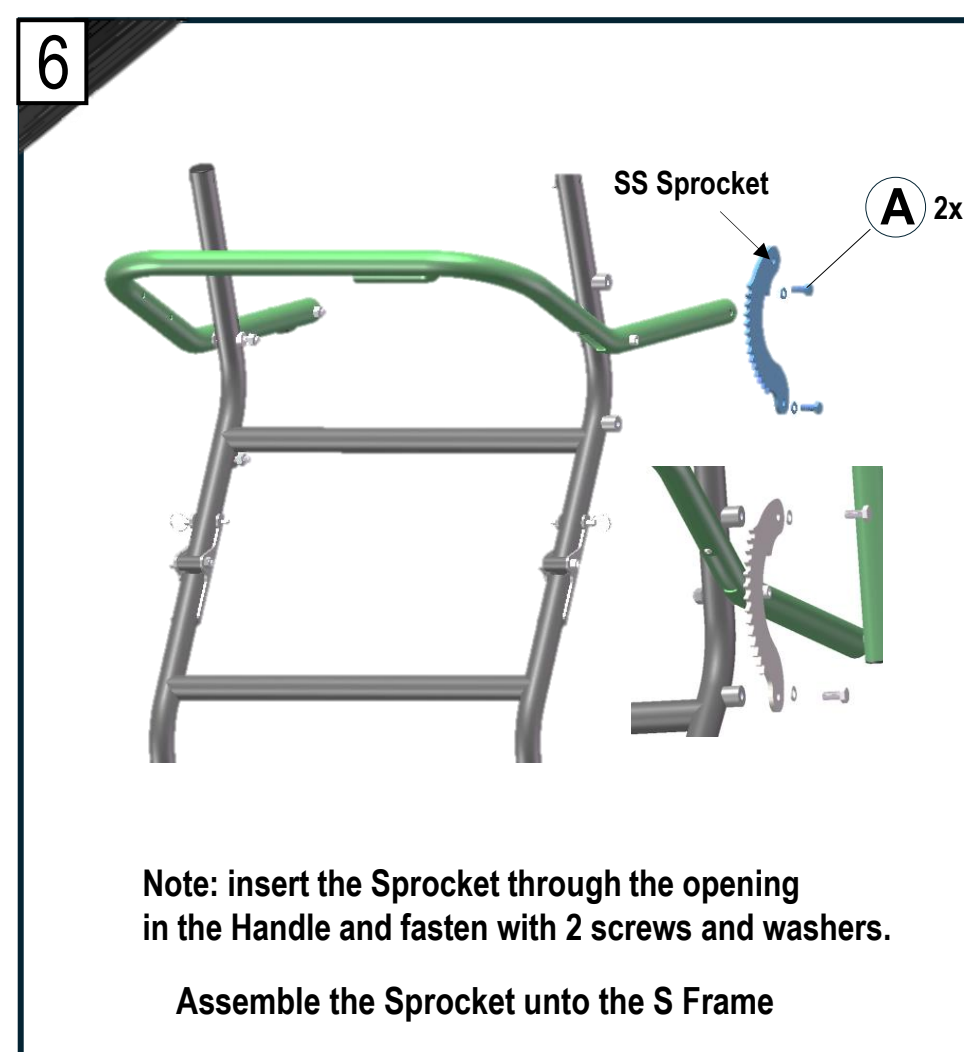
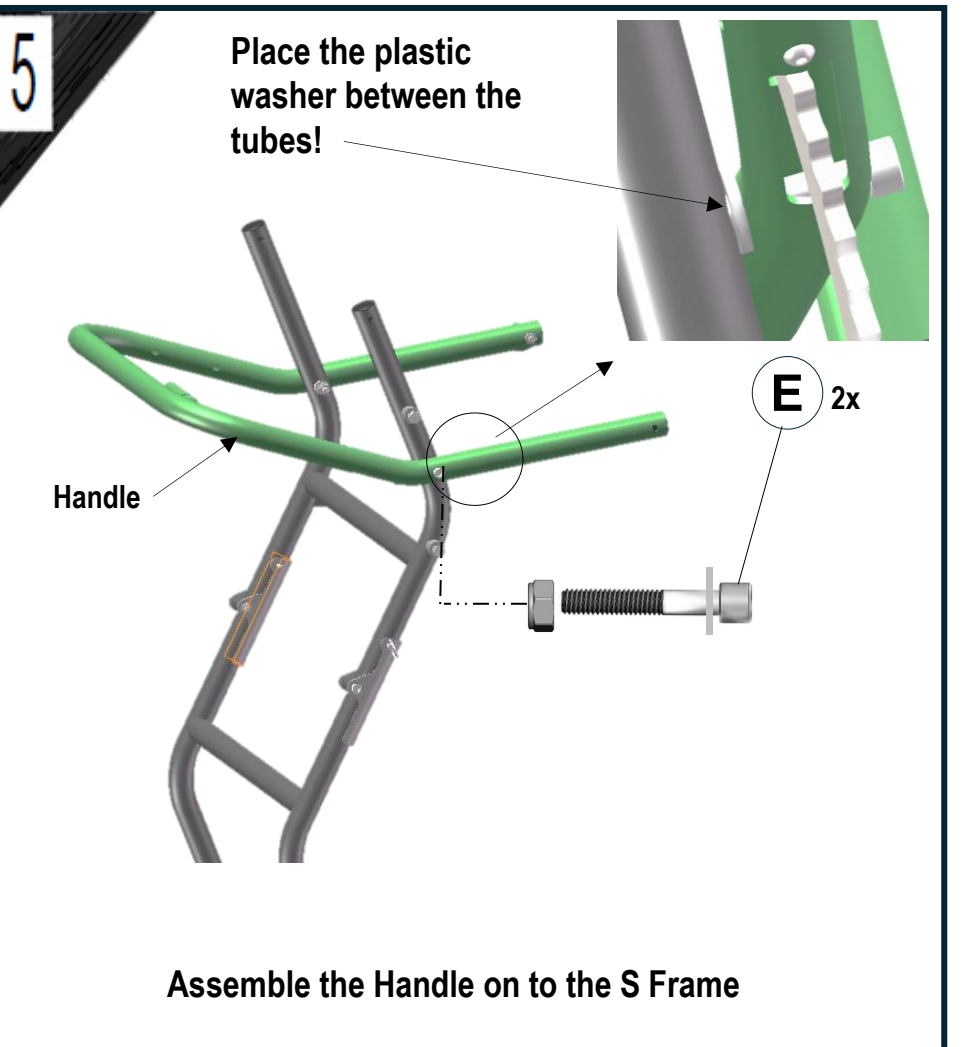
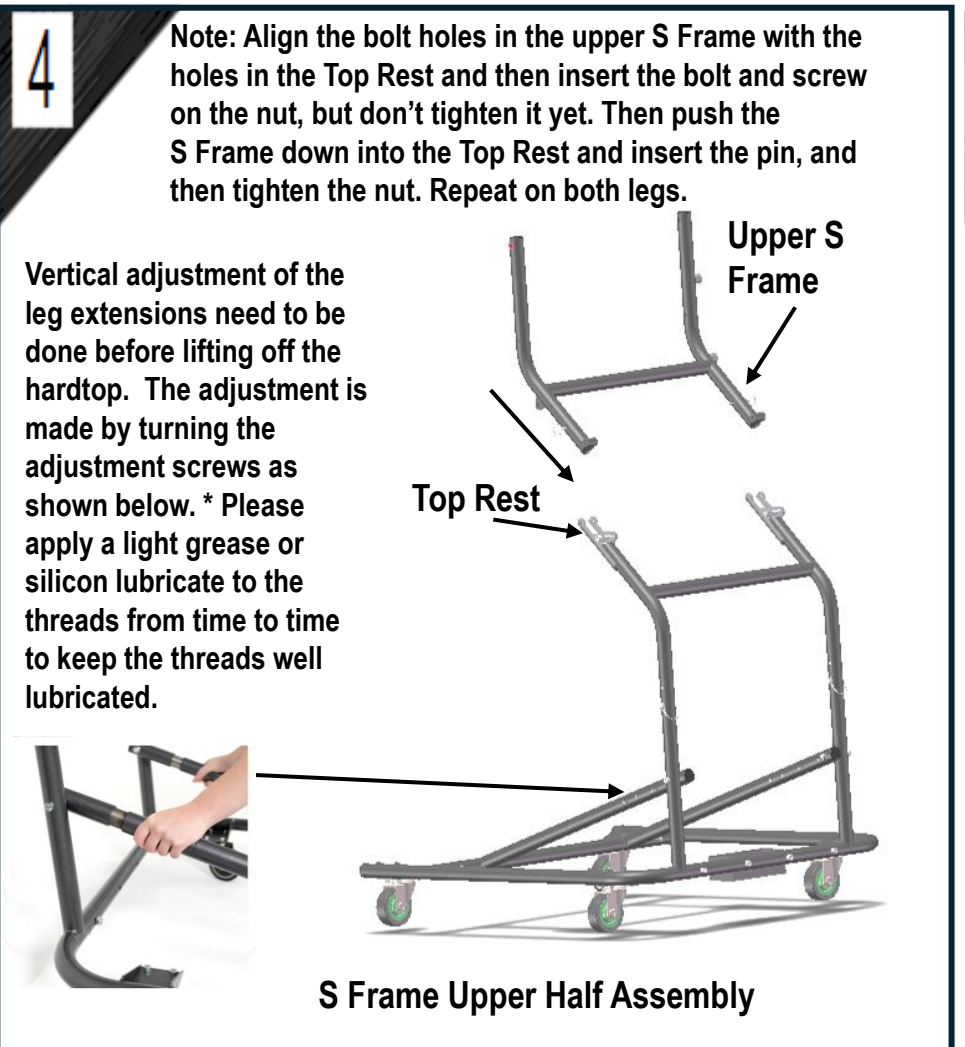
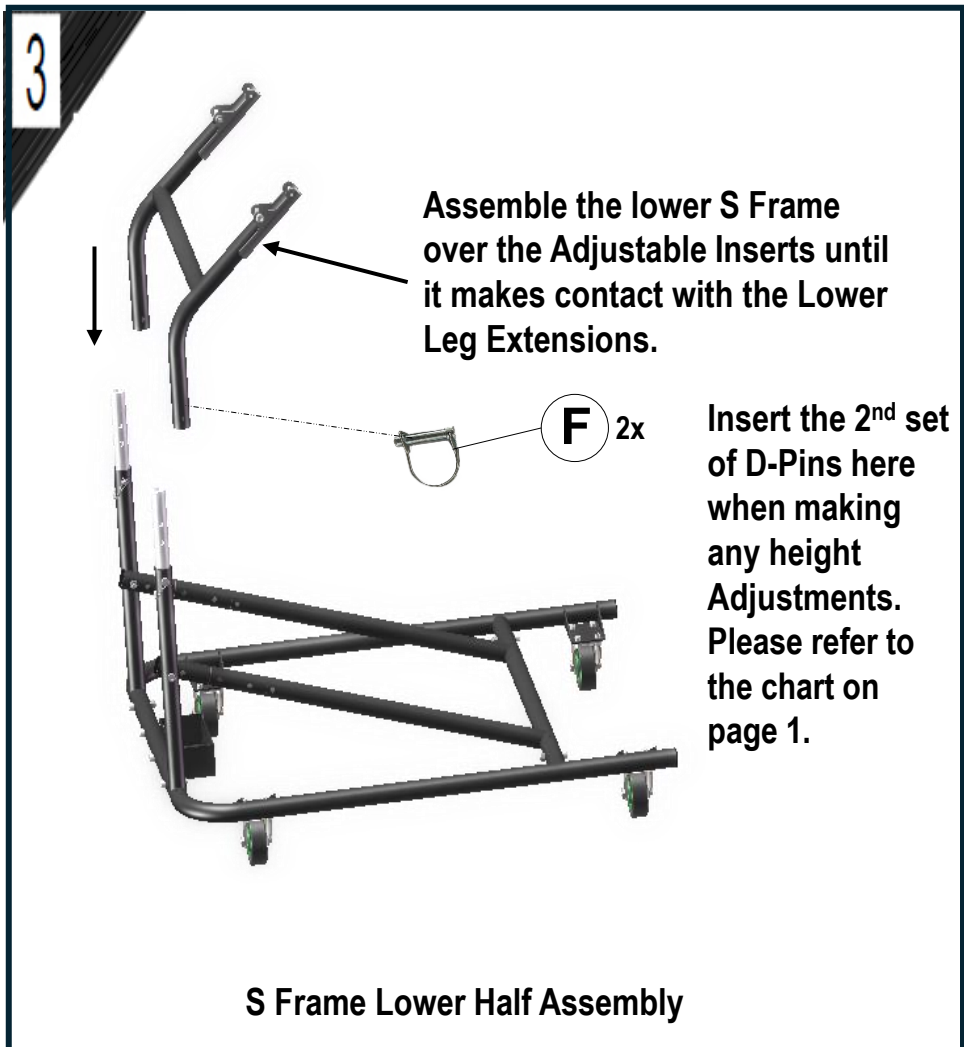
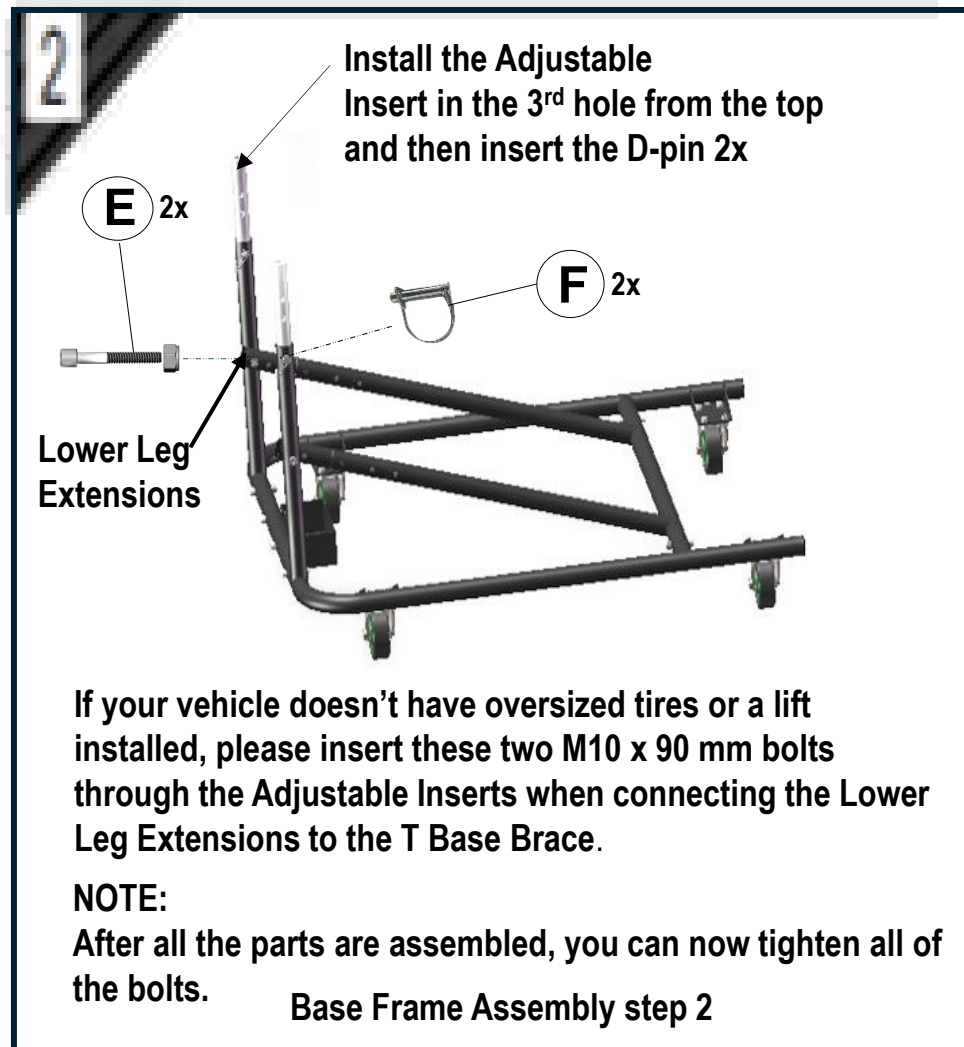
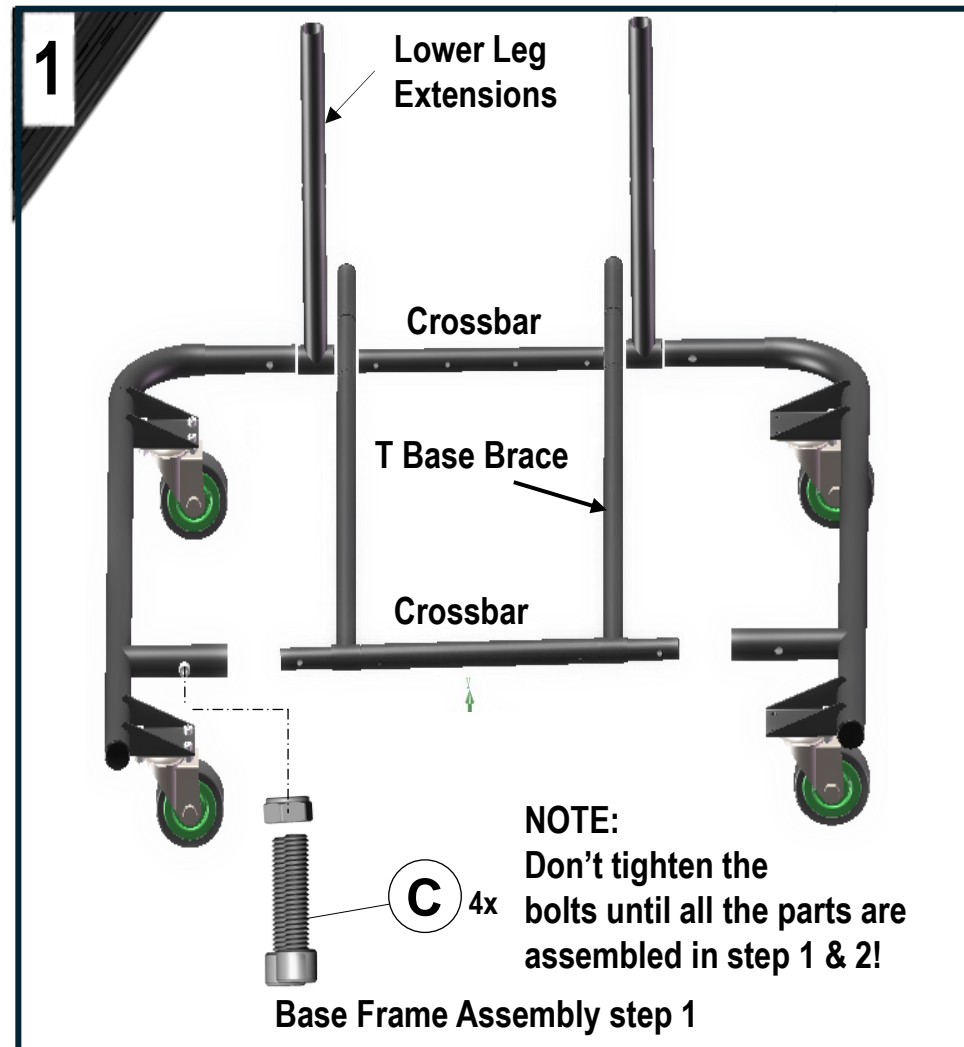

Note: Please read steps 1-10 carefully before starting the assembly process in-order-to make sure each step is assembled properly. Please make sure you place the washers as noted between the tubes when assembling item (E) located in (8) different places.

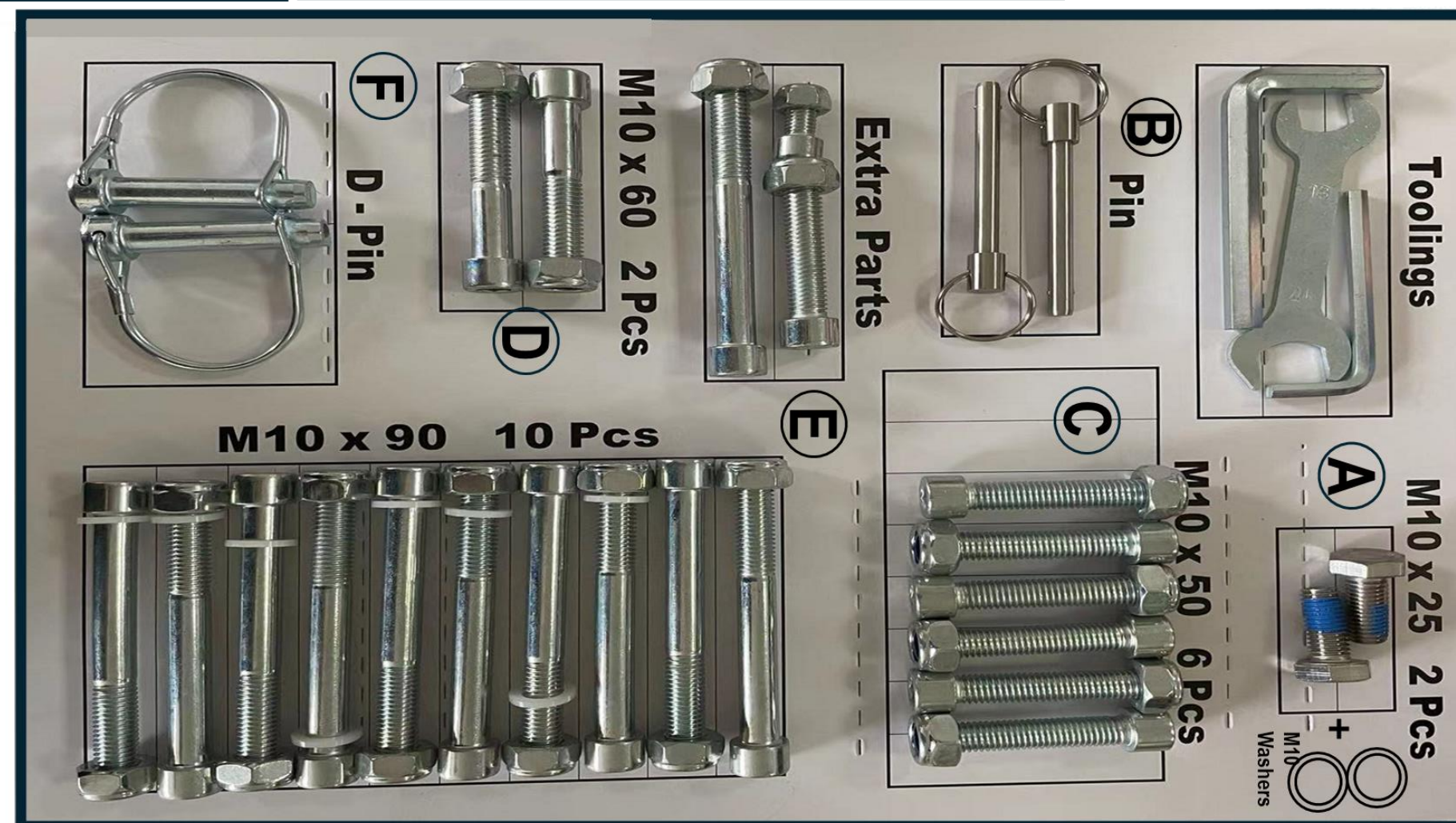

Hardware required for Assembly

TOPLIFT PROS™
4210 Dow Rd
Melbourne, Florida 32934
321.425.4336
info@topliftpros.com

LIMITED LIFETIME WARRANTY

Warranty

Alien Technologies Corp warrants your product to be free from defects in metal tube materials and workmanship for lifetime from original date of purchase or receivership of shipping, whichever is determined to be date of ownership. If you discover a defect in a product covered by this warranty, we will repair / replace using new parts and if repair is not possible, replace item. All moving parts are warranted for a period of twelve months.

Exclusions

This warranty covers defects in manufacturing discovered while using the product as recommended by the manufacturer. The warranty does not cover loss of theft, nor does coverage extend to damage caused by misuse, abuse, unauthorized modification, improper storage conditions, lightning, or natural disasters. The warranty does not cover parts that are subject to normal wear and tear replacement requirements, such as casters worn from constant use.

Exclusions

Should this product fail, your sole resource shall be repair or replacement, as described in the preceding paragraphs. We will not be held liable to you or any other party for any damages incurred as a result from improper use and failure of this product. Damages excluded include, but are not limited to, the following; damage to vehicle, other equipment, dwelling, and incidental or consequential damages arising from the use, or inability to use this product. In no way will Alien technologies Corp be liable for more than the purchase price of your product, not to exceed the current list price, and excluding tax, shipping and handling charges.

Alien technologies Corp disclaims any other warranties, express or implied.

How To Obtain Service Under This Warranty

Please contact Alien technologies Corp via phone 321.425.4336 or email at info@topliftpros.com



TOPLIFT PROS™
4210 Dow Rd
Melbourne, Florida 32934
321.425.4336
info@topliftpros.com

PATENT US 9,643,823 B2

All Rights Reserved. TopLift Pros / Alien Technologies Corp., TopLift Pros 2024-2025