

## ! IMPORTANT

### READ BEFORE YOU BEGIN INSTALLATION

**IT IS CRITICAL FOR YOUR SAFETY THAT YOU CAREFULLY READ AND FOLLOW THE SAFETY CAUTIONS AND INSTALLATION INSTRUCTIONS BOTH PRIOR TO AND DURING INSTALLATION.**

#### USER SAFETY CAUTION

During installation, be mindful of the potential for sharp edges on the product or vehicle. Taking proper safety precautions helps ensure a safe and smooth installation process.



**Always wear protective gloves and handle components with care to reduce the risk of injury.**

#### TEMPERATURE SURFACE CAUTION

During high temperatures or extended sun exposure, surfaces of this product may become hot to the touch, posing a risk of burns or injury. Use caution when handling the product in hot weather and allow time for it to cool before contact.



**Always check surface temperature before use to ensure safe handling conditions.**

#### FASTENER TORQUE CAUTION

All fasteners must be tightened to the specified torque values provided in the installation instructions to ensure proper fit and safe operation of the tonneau cover. Under- or over-tightening can lead to product failure, potential damage to your vehicle, injury, or safety hazards while driving.



**Always use a calibrated torque wrench and follow the specifications in the installation instructions.**

#### PINCH POINT SAFETY CAUTION

This tonneau cover may create pinch points when closing or operating near solid surfaces such as the truck bed rails or tailgate. To prevent injury, keep hands, fingers, and other body parts clear of moving parts during operation.



**Always operate the cover slowly and with caution to ensure safe and proper use.**

# IMPORTANT

## READ BEFORE YOU BEGIN INSTALLATION

IT IS CRITICAL FOR YOUR SAFETY THAT YOU CAREFULLY READ AND FOLLOW THE SAFETY CAUTIONS AND INSTALLATION INSTRUCTIONS BOTH PRIOR TO AND DURING INSTALLATION.

### ENTRAPMENT SAFETY WARNING

This tonneau cover does not feature a manual release mechanism from inside the truck bed. To prevent the risk of entrapment, never allow anyone to be inside the bed of the truck when the cover is closed.

**Always ensure the area is clear before closing the cover, and keep the cover securely latched when not in use to avoid accidental closure.**

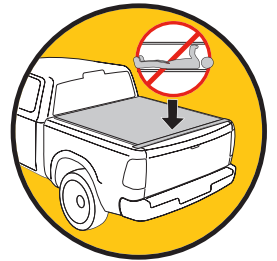

### CARGO TRANSPORT WARNING

Do not attempt to close the tonneau cover over cargo that is taller than the depth of the truck bed.

Never force the cover to close improperly.

**Forcing the cover can:**

- Prevent the cover from lying flat and latching securely.
- Damage the cover's hinge and cause the cover to kink.
- Damage the rear tail panel and cause it to become detached.

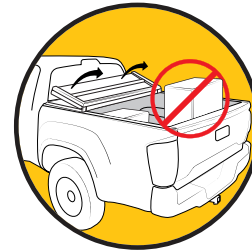

# SOLID FOLD ALX RAMBOX INSTALLATION SHEET

**Any damaged or missing parts?**

Parts will be shipped to you directly.

Call 800-877-2588, Mon - Fri, 8:30 a.m. - 6:00 p.m. EST

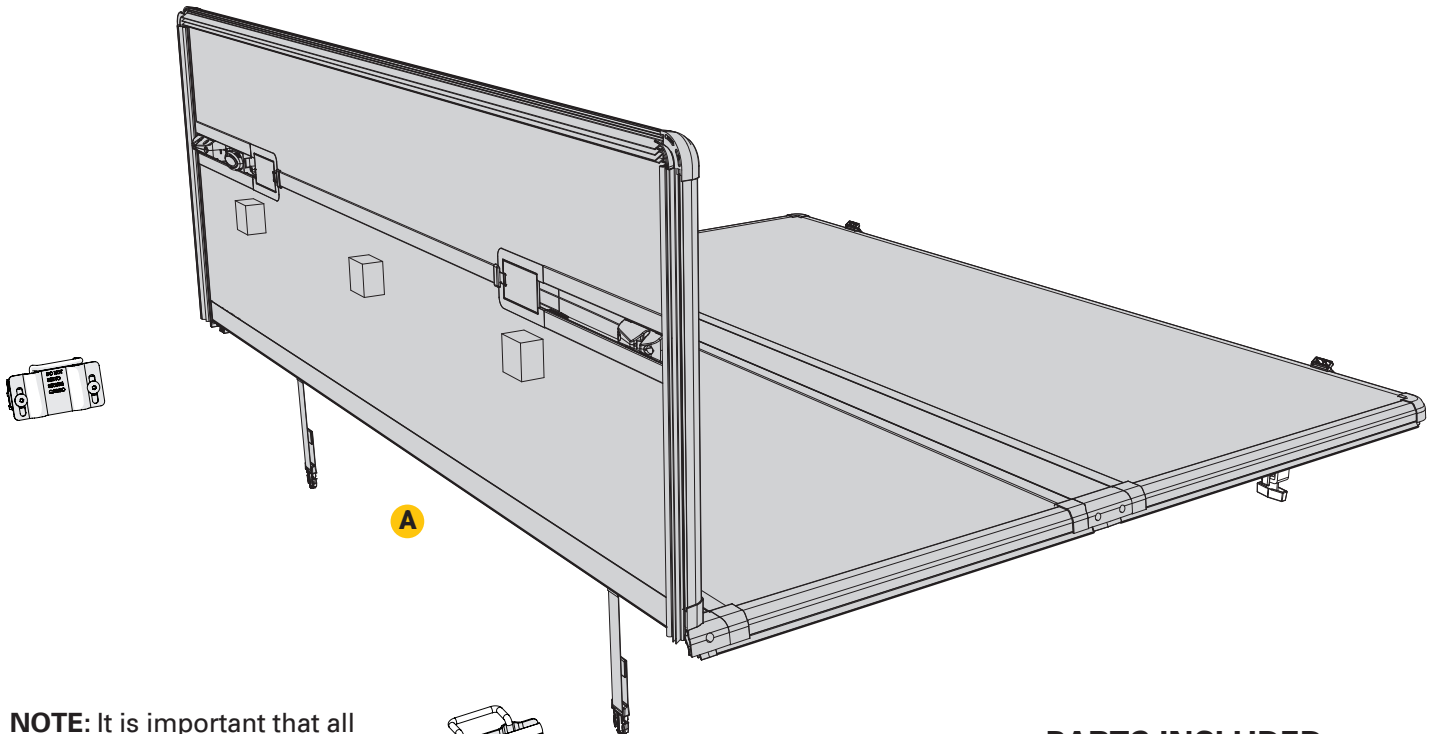

**NOTE:** It is important that all areas where the bed cover mounts are clean and free of debris prior to installing.

## PARTS INCLUDED IN YOUR KIT

- A** Cover assembly
- B** 2x Striker brackets\*
- C** 2x Backing plates\*
- D** 4x Weld nuts\*
- E** 4x Torx screws\*
- F** 6x Lock blocks
- G** 6x Lock block screws
- H** 2x Adapter rails
- I** 1x Seal tape
- J** 2x Rail end seals
- K** 2x Flat D-seals
- L** 2x Ribbed D-seals
- M** 2x Rail end cap (R/L)
- N** 2x Rail end cap screws

\* Comes pre-assembled

## TOOLS PROVIDED:

- Torx wrench - T-20
- Torx wrench - T-27
- Hex wrench - 2.5MM
- Hex wrench - 3/16"

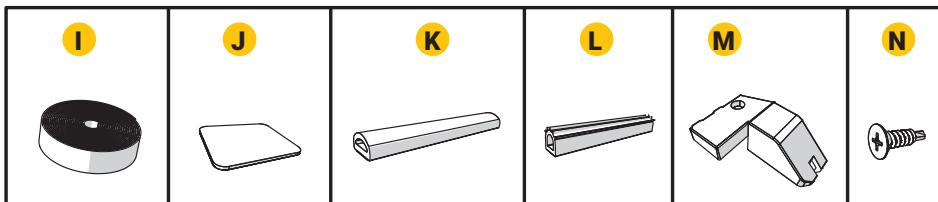
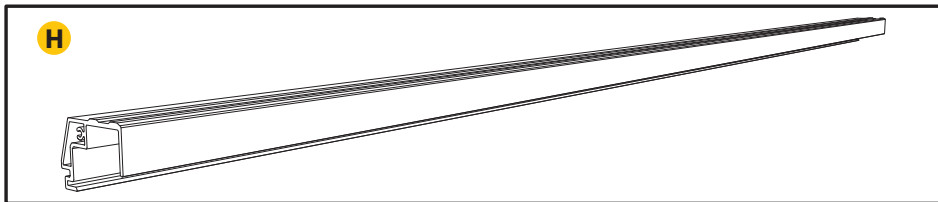
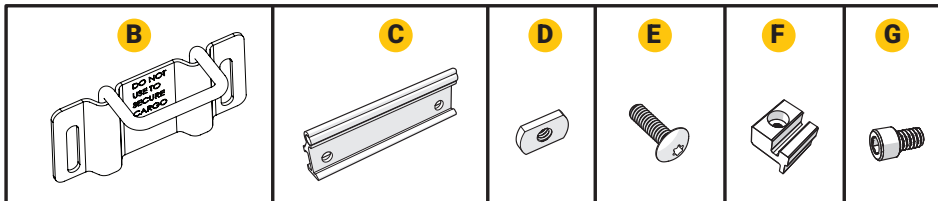

**1** Remove the factory accessory rails.

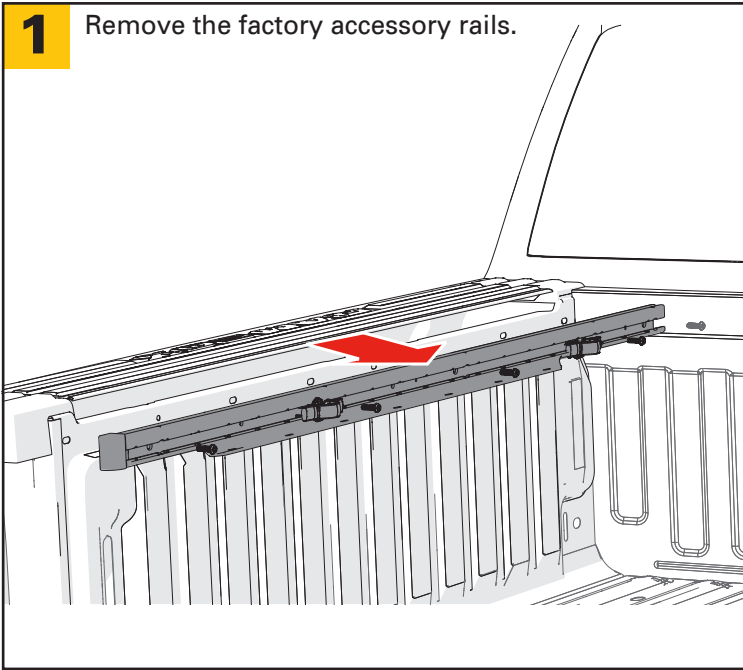

**2** Apply the roll of flat seal (I) along the bed. Make sure the seal extends beyond the ends of the accessory rail, from the bulkhead through to the back corner trim cap. Do this for both driver and passenger sides.

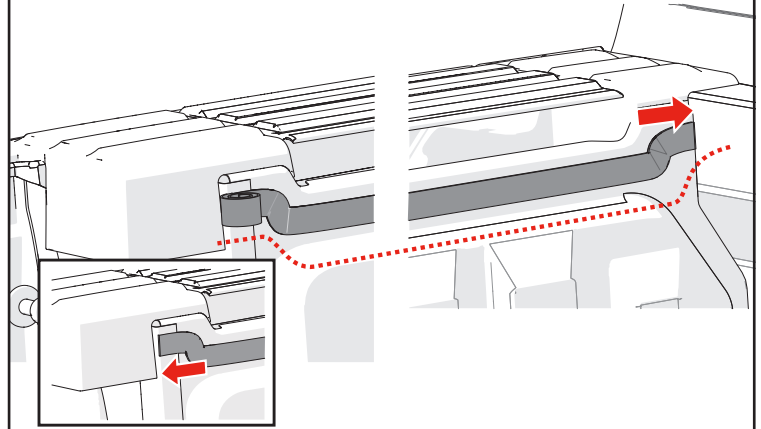

**3** Place the flat D-seal (K) to continue the flat seal (I) across the back end cap.

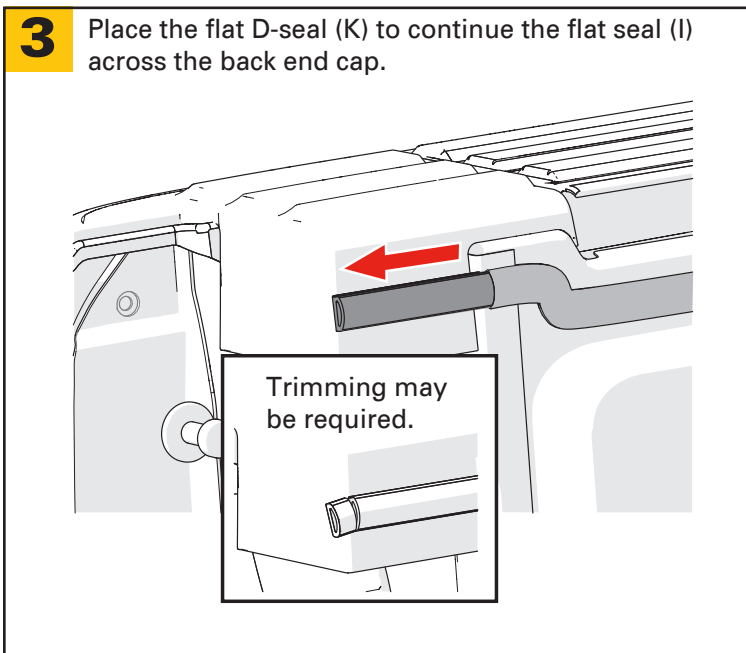

**4** With the seals (I & K) in place on both sides, reinstall the factory accessory rails to 5.5 ft-lbs (7.5 Nm).

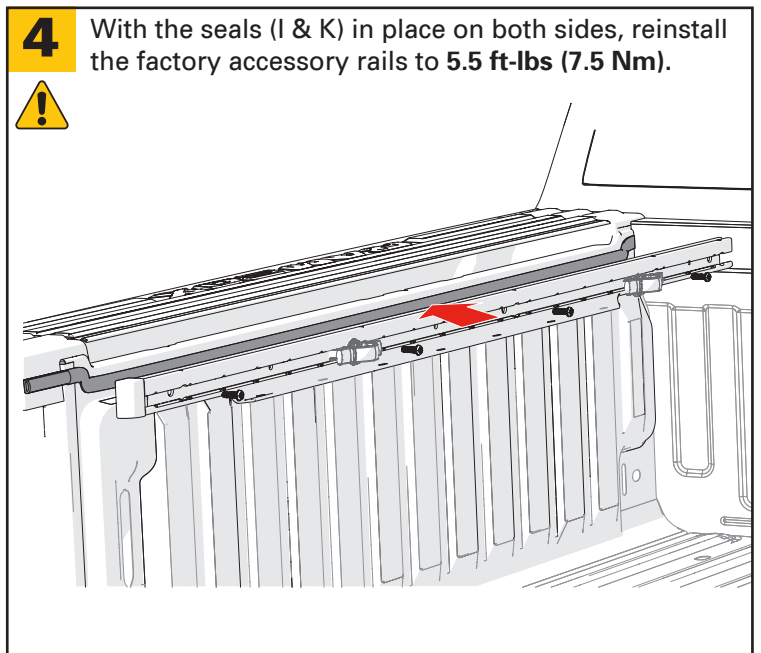

**5** Remove the factory accessory rail end caps.

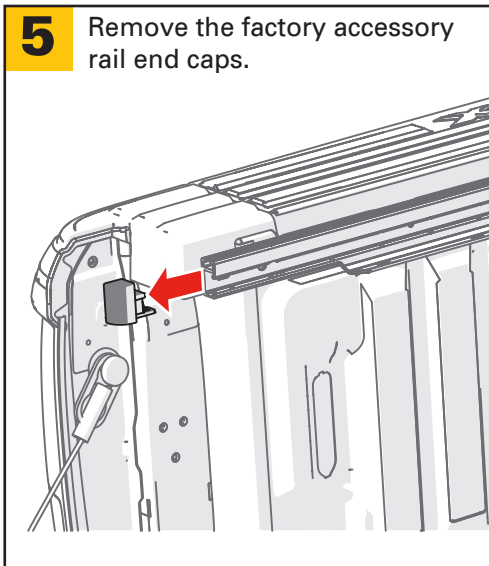

**6** Place the adapter rail (H) into the top of the factory accessory rail and slide it toward the cab.

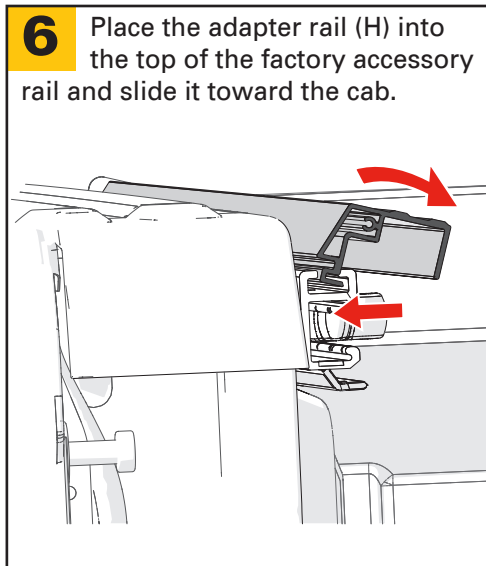

**7** Before the adapter rail (H) is slid completely to the bulkhead, remove the backing and attach a rail end seal (J). Do this for both sides.

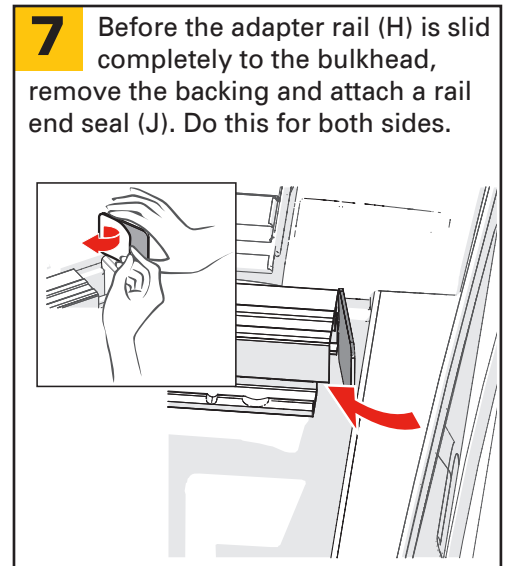

**8** Slide the adapter rails (H) and the rail end seals (J) firmly against the bulkhead.

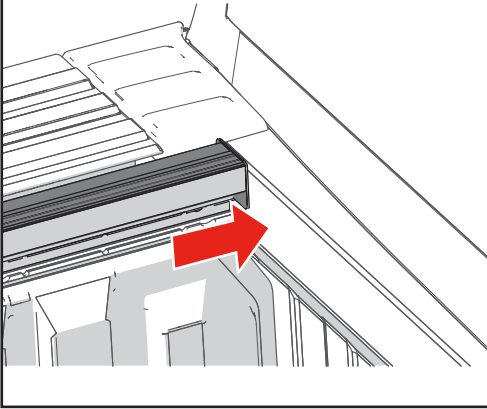

**9** Thread the 6 lock block screws (G) into each lock block (F).

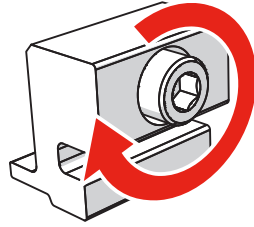

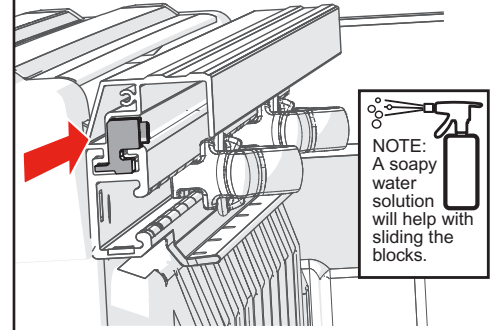

**NOTE:** Keep the screws loose, they will be tightened after they are inserted into the rail.

**10** Slide 3 lock blocks (F) into each adapter rail (H) and the top of the accessory rail.

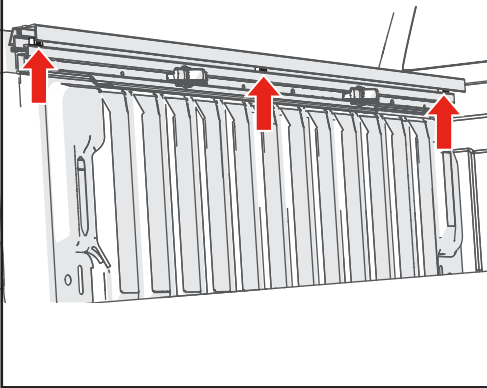

**11** Evenly space the lock blocks (F) on both driver and passenger sides.



**12** With the adapter rail (H) firmly pressed up to the bulkhead, tighten each lock block (F) with the 3/16" hex wrench provided to 5 ft-lbs (6.8 Nm) 

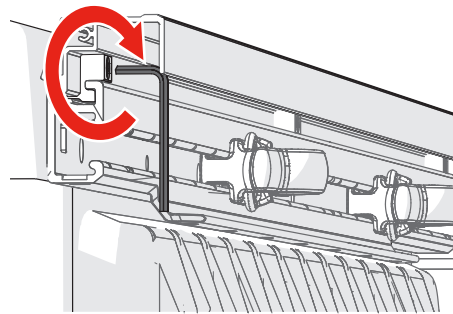

**13** Attach the rail end caps (M) to the adapter rail (H) with the flat rail end cap screws (N).

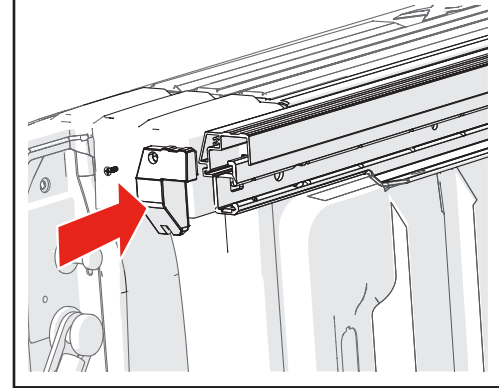

**14** Adhere the ribbed D-seal (L) in the end cap corner to span the adapter rail (H) end cap and rear trim panel. Add one to each side. Trimming the seal may be required.

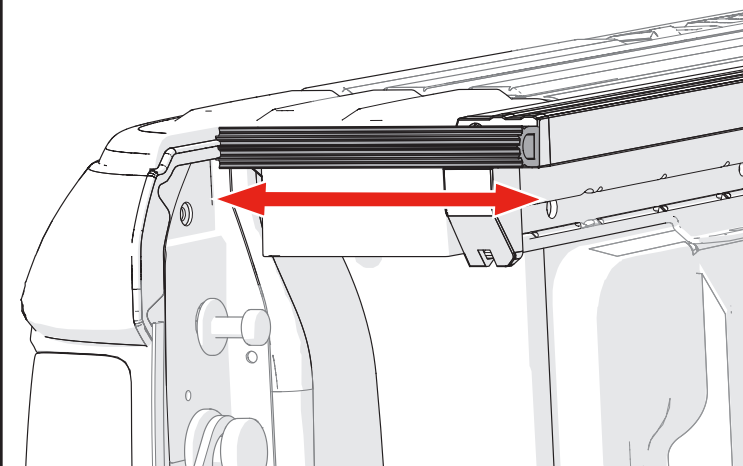

**15** Place the cover (A) onto the truck bed rails and bulkhead. **NOTE:** Take care not to damage or deform the cover seals while installing the cover.

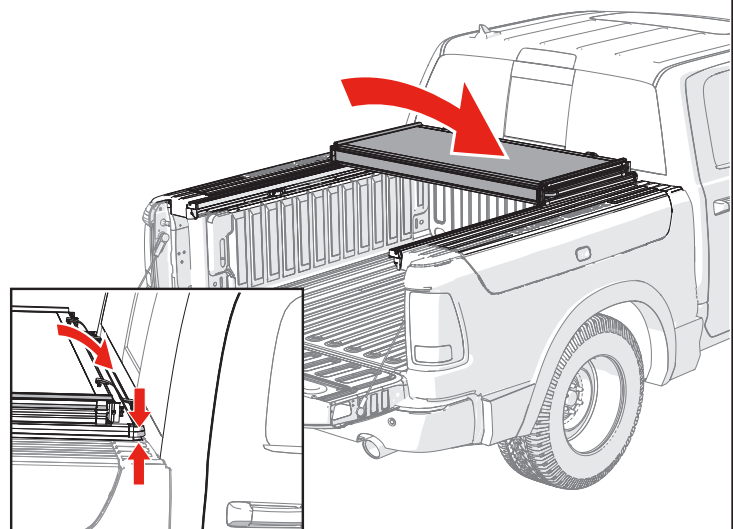

**NOTE:** When placing the cover (A) onto the bulkhead the corner seal will slide down in front of the cover rail.

**16** Swing the clamps so the clamp jaw is under the adapter rail (H) so the side seal is tight to the bed caps.

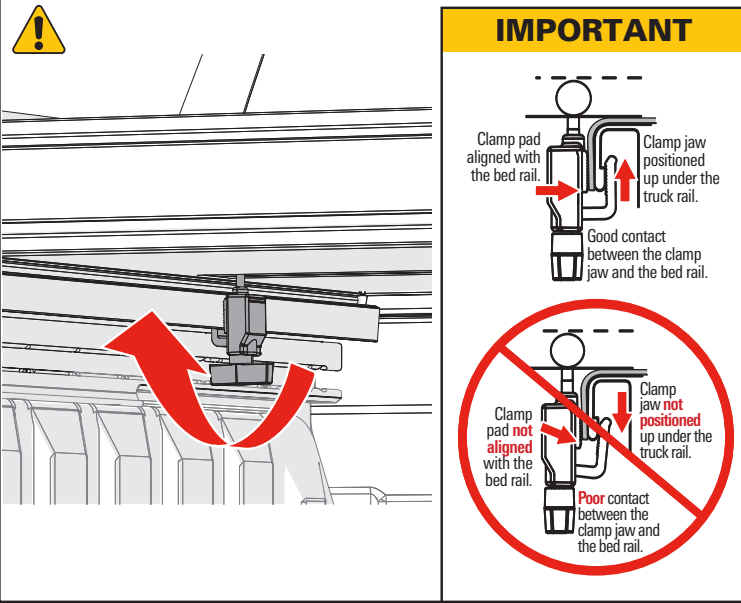

**17** Do not use a wrench or overtighten. Hold down on the cover so the seal is tight to the bed. Tighten the clamp securely so that the cover does not slide/shift or lift from the truck bed.

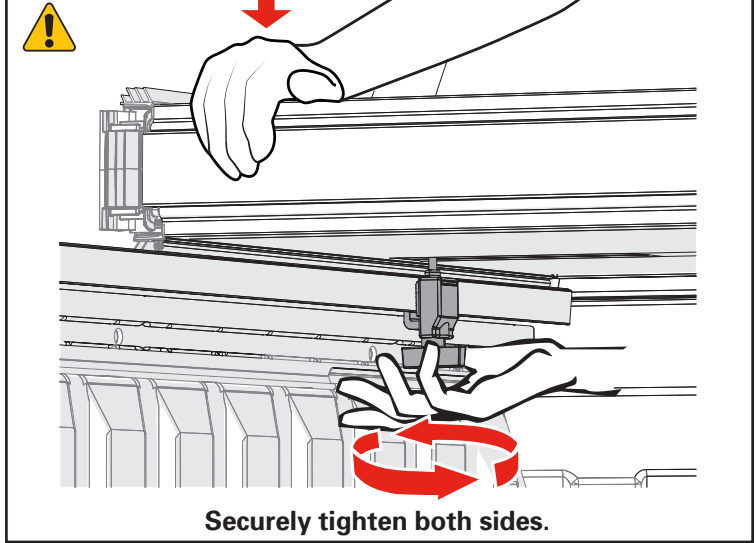

**18** The tethers come installed on the bed cover hinge with a clamp at the other end. Install the clamp end by sliding the clamp onto the adapter rail (H). Make sure the clamp is positioned as far up onto the rail as possible. Firmly hand tighten the knobs. Install the tethers on both sides of the cover.

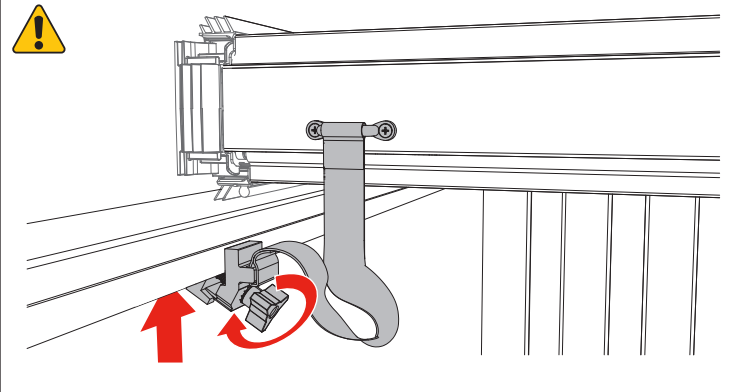

**19** Close the tailgate and unfold the cover. Check that the cover is parallel and square with the truck bed and bed rails. If not parallel or square, open the cover and loosen the cab clamps to reposition the cover. Adjust and re-tighten both clamps.

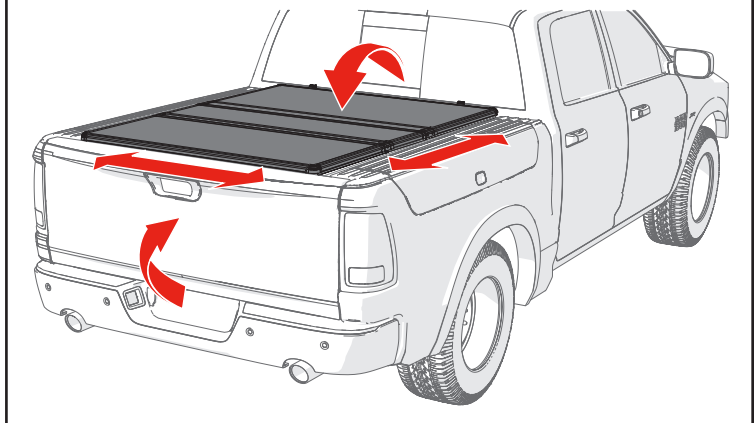

**20** Install the striker bracket (B) by loosening the Torx screws (E) until there is enough space for the backing plate (C) to fit behind the adapter rail (H) while the striker bracket plate (B) fits on the front of the adapter rail (H).

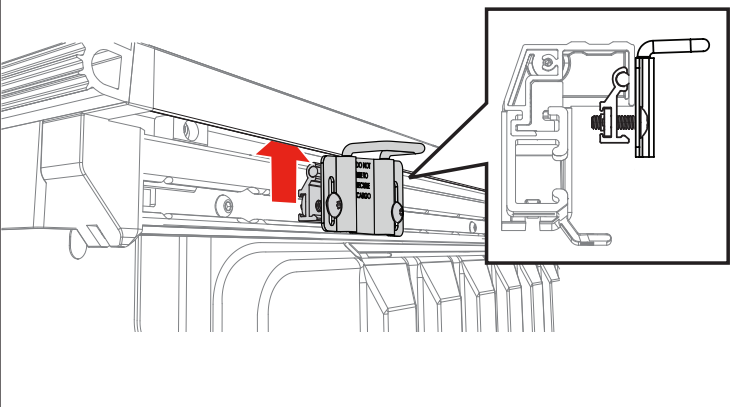

**21** Close the cover (A) and align the striker bracket (B) with the bed cover latch. Push down on the cover while tightening the Torx screws (E) to 3 ft-lbs (4 Nm).

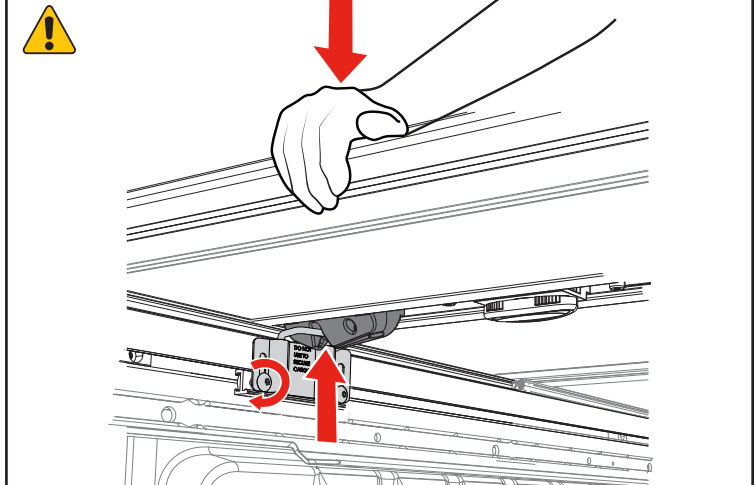

## 22 Adjustments and tightening of the latch assembly is required.

The bed cover latch assembly comes from the factory only partially tightened to allow for installation adjustments. **Only use the hand tools provided, do not use power tools.**

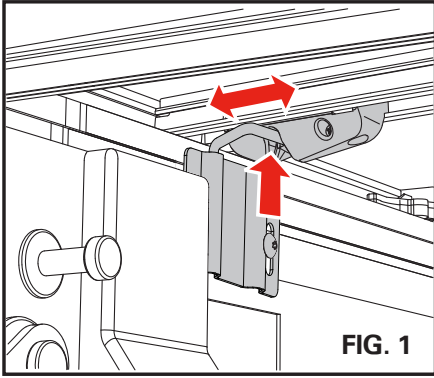

Lower the rear of the bed cover and adjust the position of each latch so that they engage with the striker brackets, (Fig. 1). With the latches adjusted, from underneath the cover, use the provided T-20 Torx wrench to tighten the two screws, (Fig. 2) so the latch does not move in the channel. Repeat on the other side.

Rotate the actuator knob until you see the flat head screws. Tighten the two screws using the provided 2.5mm hex wrench, (Fig. 3).

The cable comes routed through the barrel clamp and hangs out. Insert the cable through the middle of the passenger side of the actuator assembly. On the driver's side of the actuator, leave 3/4" - 1" (19.1 - 25.4mm) of cable extending through the barrel clamp, for future adjustments, (Fig. 3) so the knob does not move in the channel. Repeat on the other side.

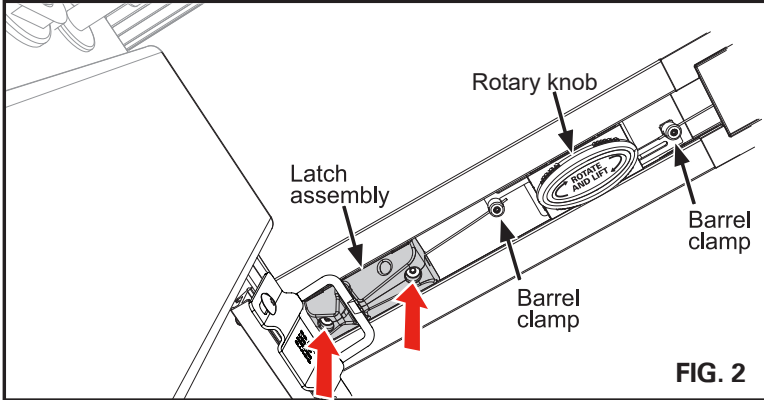

Next, tighten the actuator mechanism set screws, (Fig. 4) with the provided 2.5mm hex key to secure the latch cables. Rotate the actuator knob, (Fig. 4) to verify that the latches disengage from the striker brackets.

Double-check that the cover is secure and tight to the truck bed by gently lifting the corners to ensure the mechanisms are engaged.

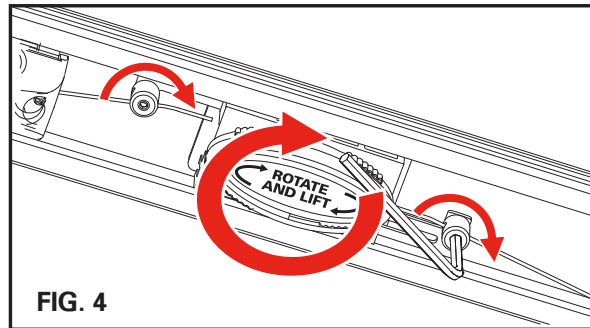
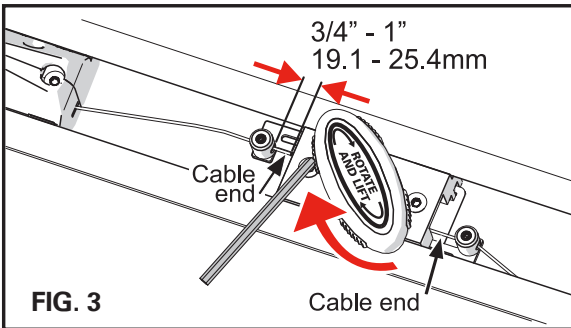

### Opening the cover

Open the cover by twisting the actuator knob and lifting the cover.

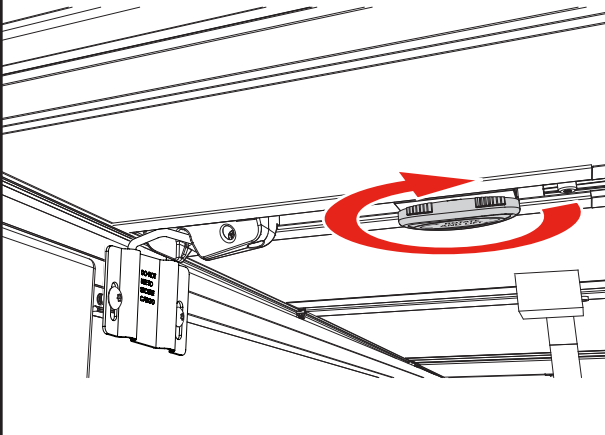

### Securing the cover

To drive with the cover open, fold the cover forward to the cab and fasten BOTH straps in the middle section to the front rail. Check that the straps are tight, and pull the strap end if too loose.

**⚠ FAILURE TO DO SO COULD RESULT IN DAMAGE TO THE COVER AND TRUCK.**

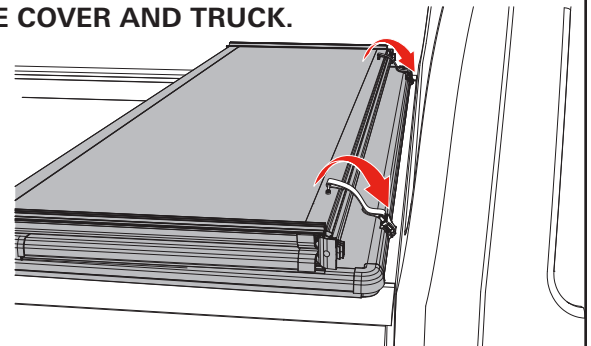
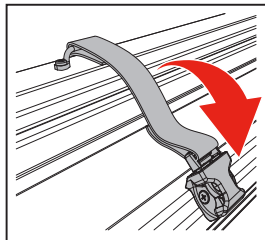

## ! IMPORTANT

Re-tighten the front/cab clamps and tethers after the first week of driving the vehicle. Also periodically check the clamps and tethers to ensure they are secure.

**Closed/Extended Position** – Bed cover must be completely secured by all four (4) clamps.

**Open/Folded Position** – Bed cover must be completely folded up (all panels) and secured at the cab with the provided buckle straps and with both tethers attached.

**Do NOT** drive with the bed cover in a partially open position.

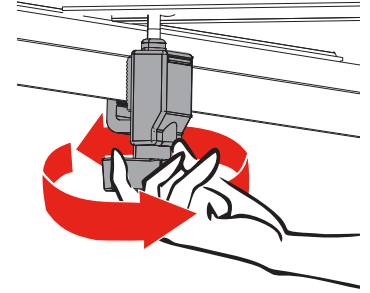

Do NOT allow the vehicle to be towed backwards without first removing the cover from the vehicle.



Remove any snow or foreign matter before folding the bed cover.

## LIMITED WARRANTY

### WARRANTY COVERAGE

This truck bed cover is warranted against defects in materials or workmanship as follows. This warranty is void if the product has been damaged in an accident, or due to neglect, unforeseeable use, improper installation, improper servicing, or other cause not arising out of defects in material or workmanship.

**The truck bed cover carries a limited warranty for five (5) years from the original date of purchase, subject to the terms below.**

### WARRANTY IS NOT TRANSFERABLE

The warranty is to the initial owner purchasing the truck bed cover and it is not transferrable to a subsequent end user. Proof of purchase may be required to enforce these warranty rights.

### WARRANTY CONDITIONS

Failure to follow these care and use instructions will void the warranty.

- Clean with mild automotive soap and water only.
- Cover must be secured at all points when vehicle is in motion. When not fully extended, cover must be completely folded up and secured at the cab with the provided buckle straps and tethers attached. Do NOT drive with the bed cover in a partially open position.
- Check all clamps and retention mechanisms for tightness after a week of driving following installation (or re-installation) of the cover and periodically thereafter.
- Before opening, cover must be free of all foreign materials including snow and ice.
- Do NOT tow your vehicle from the rear with the cover on your vehicle. If towing from the rear is required, the cover MUST be removed from the vehicle and properly stored.

### WARRANTY PERFORMANCE

If all warranty conditions are met, a defective truck bed cover or hardware component will either be repaired or replaced (at our option). We reserve the right, for any warranty, to substitute a newer model or bed cover having similar form and function, to offer a warranty discount on an entire replacement system, and/or provide remedies other than those mentioned in this document.

### WARRANTY PROCESS

A Return Authorization number must be obtained from our Customer Service Department prior to returning any product. We may require the original item to be returned postage prepaid for final determination. Shipping charges will apply for any repair or replacement. Other than postage or shipping charges, no charge will be made for repair or replacement under this warranty.

This warranty gives you specific legal rights. As an owner, you may also have additional rights and remedies under the laws of your state.

### WARRANTY REGISTRATION

Warranty registration must be on file and/or proof of original purchase (detailed and dated receipt) required for warranty to be effective.

Register online at <https://realtruck.com/extang-warranty>

**REGISTER  
YOUR  
WARRANTY  
ONLINE**



# REPLACEMENT PARTS

Replacement parts can be ordered online at [extang.com/replacement-parts](http://extang.com/replacement-parts) or you can contact our Customer Service Department for assistance. When ordering, xxx represents the 3 digit suffix, as referenced on the sales receipt or vehicle application list.

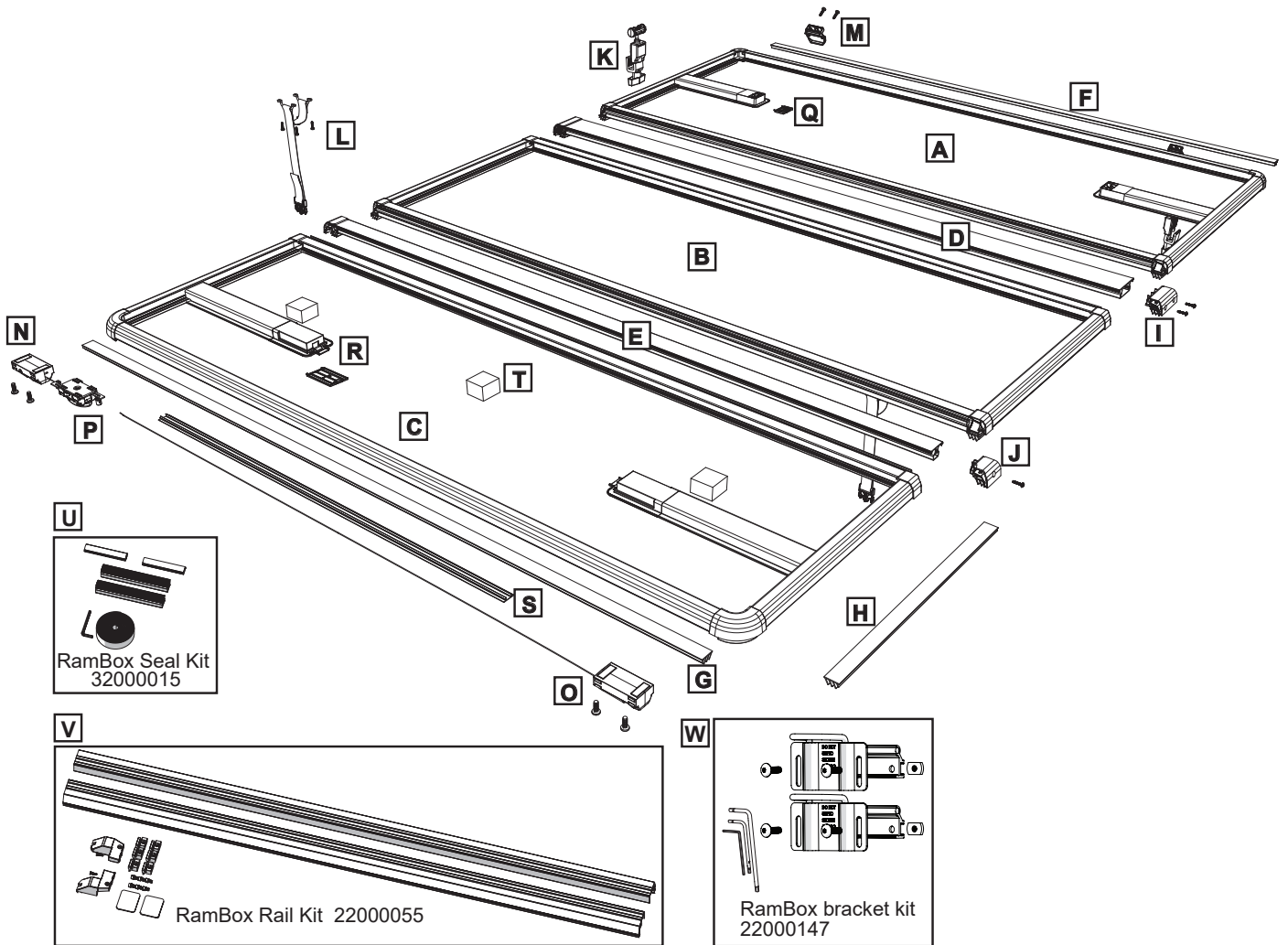

Call Out	Title	Part Number	Description	Qty
A	Cab Panel	88xxx-60	Cab panel assembly	1
B	Mid Panel	88xxx-61	Mid panel assembly	1
C	Tail Panel	88xxx-62	Tail panel assembly	1
D	Cab Hinge	88xxx-63	Cab hinge assembly	1
E	Tail Hinge	88xxx-64	Tail hinge assembly	1
F	Cab Seal	32002112	Single length seal (68"), hollow seal, cut to fit	1
G	Tailgate Seal	32563200	Single length seal, (68"), 4-fin, cut to fit	1
H	Side Seal	32000685	Single length (68") Side Seal, cut to fit	1
I	Cab Hinge Cap Kit	31830010	Cab hinge cap & fasteners	1
J	Tail Hinge Cap Kit	31830020	Tail hinge cap & fasteners	1
K	Front (Cab) Clamp	*	Front clamp assembly*	1
L	Tie Down Kit	31831010	Male buckle Strap & fasteners	1
M	Cab Buckle Kit	31830002	Female buckle & fasteners	1
N	Latch Assembly, Driver	28900100	Autolatch assembly for the driver side	1
O	Latch Assembly, Passenger	28900101	Autolatch assembly for the passenger side	1
P	Rotary Release Assembly	28900102	Rotary assembly	1
Q	Latch Pocket Cover, Cab	35830102	Plastic cover for the latch pocket on the cab panel	1
R	Latch Pocket Cover, Tail	35880002	Plastic cover for the latch pocket on the cab panel	1
S	Cable Cover	35880003	Snap-in cable cover	1
T	Spacer Pad	32622500	Foam adhesive backed pad	1
U	RamBox Seal Kit	32000015	A kit of seals for the Ram Box installation, also a hex wrench for use in the rail install.	1
V	RamBox Rail Kit	22000055	A kit of rails and hardware to use to mount the bed cover to the Ram Box bed.	1
W	RamBox Bracket Kit	22000147	A pair of assembled striker brackets for the rear/tailgate end.	1

\* Specify, year, make, model, long or short bed, driver or passenger side.

**SOMETHING DAMAGED? MISSING PARTS?**

---

**CALL US FIRST**  
**800-877-2588**

**WE CAN HELP YOU QUICKLY AND EASILY OVER THE PHONE**

---

Experienced Customer Service staff are available  
to answer all your truck bed cover questions

**CUSTOMER SERVICE HOURS**

**8:30 a.m. TO 6:00 p.m. EST, MONDAY - FRIDAY**

Truck bed cover model: \_\_\_\_\_

Purchase date: \_\_\_\_\_

Lot code: \_\_\_\_\_

*Lot code can be found on the underside of cover.*