

Pressure Switch - Hobbs

Adjustable and Static

4-HOBBS-X (2, 5, 10, and 15)



A Hobbs switch is a must-have for any boosted performance application requiring precise control of secondary systems. It automatically activates secondary fuel pump relays or high-speed modes on brushless pumps when boost pressure reaches a set point. This ensures your engine always receives the fuel volume it needs under demanding conditions, protecting it from lean-out or power loss. Available in a range of pressure thresholds to suit various setups, the compact and rugged design makes for easy integration into any build.

- Available in Adjustable or Static Pressure models
- Adjustable versions available in 1-3psi or 8-12psi
- Static versions available in 5psi and 15psi
- 1/8" NPT tapered male thread attachment
- Connectors included
- Endurance tested for maximum reliability

Specifications

Weight (Adj/Static)	3 / 2 oz (86 / 54 grams)
Amperage Rating	0.5 Amps
Inlet Fitting	1/8"-27 NPT (Tapered Pipe Thread)
Wiring Adjustable	Integrated 2-Pin Connector
Wiring Static	6" Flying Leads with 2-Pin Connector
Connector Adj.	6" Pigtail Connector Included
Connector Static	6" Pigtail Connector Included

**Pressure switch only, Does not work with Vacuum*

Drawing

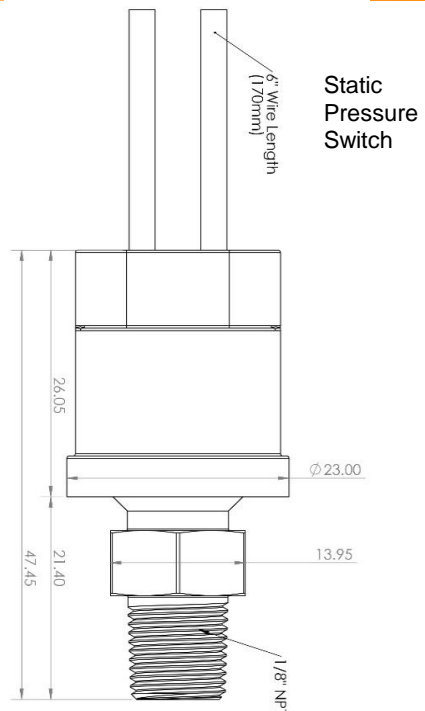
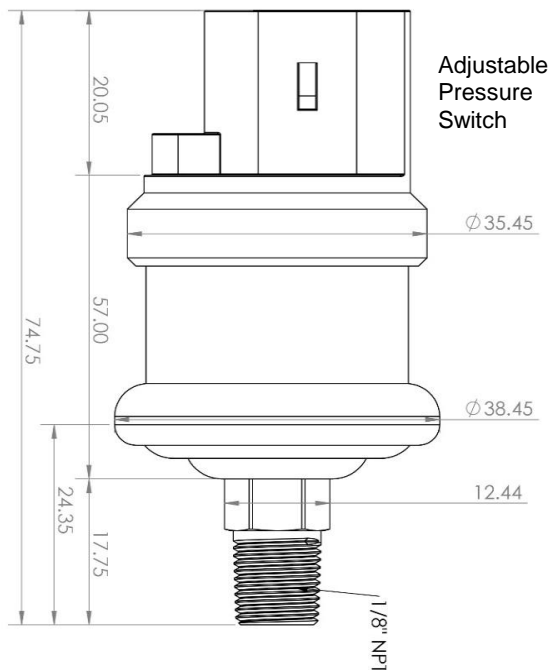

THIS PRODUCT MAY BE USED SOLELY ON VEHICLES USED IN SANCTIONED COMPETITION WHICH MAY NEVER BE USED UPON A PUBLIC ROAD OR HIGHWAY, UNLESS PERMITTED BY SPECIFIC REGULATORY EXEMPTION