



2007-2018 JEEP WRANGLER JK 4WD 4" Long Arm Lift Kit INSTALLATION INSTRUCTIONS



THANK YOU FOR CHOOSING SUPERLIFT FOR ALL YOUR SUSPENSION NEEDS!!

INTRODUCTION BEFORE INSTALLATION

Installation requires a professional mechanic. In addition to these instructions, professional knowledge of disassembly / reassembly procedures and post installation checks must be known.

PRIOR to beginning, inspect the vehicles steering, driveline, and brake systems, paying close attention to the suspension link arms and bushings, sway bars and bushings, tie rod ends, pitman arm, idler arm, ball joints and wheel bearings. Also check the steering sector-to-frame and all suspension-to-frame attaching points for stress cracks. The overall vehicle must be in excellent working condition; repair or replace all worn parts.

Read instructions several times before starting. Read each step completely as you go.

Be sure you have all needed parts and know where they install.

NOTES:

- 2 Door Wranglers rear drive shaft life will be reduced, due to the increased drive shaft operating angles and short shaft length
- Do NOT install this suspension system in conjunction with any other type of aftermarket or fabricated components to gain additional suspension height.
- Do not fabricate any components to gain additional suspension height.
- Prior to attaching components, be sure all mating surfaces are free of grit, grime, grease, undercoating, etc.
- Front end alignment is necessary.
- Tool and Wrench/Socket size is given in brackets [] after each appropriate step.
- A foot-pound torque reading is given in parenthesis () after each appropriate fastener.
- Always wear safety glasses when using power tools.
- A factory service manual should be on hand for reference.
- Due to payload options and initial ride height variances, the amount of lift is a 'base figure'. Final ride height dimensions may vary in accordance to original vehicle stance.

BEFORE YOU DRIVE

Check all fasteners for proper torque. Check to ensure for adequate clearance between all rotating, mobile, fixed, and heated members. Verify clearance between exhaust and brake lines, fuel lines, fuel tank, floor boards and wiring harness. Check steering components for clearance.

Test and inspect brake system. Perform steering sweep to ensure front brake hoses have adequate slack and do not contact any rotating, mobile or heated members. Inspect rear brake hoses at full extension for adequate slack. Failure to perform hose check/replacement may result in component failure. Perform head light check and adjustment.

WARNING

It is ultimately the buyer's responsibility to have all bolts / nuts checked for tightness after the first 100 miles and then every 1000 miles. The steering, suspension and driveline systems, plus wheel alignment should be inspected by a qualified professional mechanic at least every 3000 miles.

TIRES & WHEELS

Larger rim and tire combinations may increase leverage on suspension, steering, and related components. When selecting combinations larger than factory, consider the additional stress you could be inducing on the factory and related components.

ALL tire & wheel combinations should be test fit prior to installation. Some minor trimming maybe required. Some minor trimming will be required with certain wheel/tire combinations. Trimming will

normally include the bottom edge of the inner fender shrouds and/or lower corner of front bumper valance. As a rule of thumb, deeper backspacing and shorter/narrower tires will reduce/eliminate trimming required.

- 33"-35" tires can be used without fender trimming.
- 37" tires will require fender trimming.
- Maximum tire width is 12.5".
- Minimum wheel diameter is 17".
- Recommended wheel width is 8"-9".
- Minimum wheel backspacing is 4.5".
- Maximum wheel backspacing is 4.75".
- Stock wheels can be used with 33" tires, 35"-37" tires on stock wheels require a 1.5" wheel spacer is required.

IMPORTANT DISCLAIMER: The provided tire/wheel recommendations are approximate. Actual dimensions of a given tire size can vary considerably from one brand to another. Manufacturers' wheel offset and backspacing measurement points are not always consistent. Backspacing greatly impacts tire-to-fender clearance when turning. Wheel width and backspacing influence whether the tires protrude past the fenders, and to what extent.

**MAKE SURE YOU HAVE THE CORRECT LIFT FOR YOUR VEHICLE:
Double check the Year, Make, Model, Lift Height and KIT Part Numbers.**

Prior to beginning the installation, OPEN the boxes and CHECK the included components compared to the Parts Breakdown. Check all parts and hardware in the box with the parts list below. Be sure you have all needed parts and know where they install.

IF you find a packaging error, contact SUPERLIFT directly. Do not contact the dealer where the system was originally purchased. You will need the control number from each box when calling; this number is located at the bottom of the part number label and to the right of the bar code.

How to Read the Kit Breakdown Charts:

The 'KIT BREAKDOWN' lists Part Numbers, Quantities & Part Description of the individual components & Hardware Bags that are included in each box. The 'HARDWARE BREAKDOWN' lists the Part Numbers, Quantities & Part Description of the individual components.



Step	Part Number	Qty. per Kit	Description	New Attaching Hardware	Qty. per Bracket	Hardware Bag Number
FRONT						
20	2171154	1	control arm bracket, front driver side	55-07-5841 - 9/16" tab nut	1	77-5900
				2171179 - 1/2" tab nut	1	
				55-08-5841 - 1/2" tab nut	1	
				2171186 - 1/2" tab nut	1	
				1/2" x 2" countersunk bolt, coarse thread	2	
				1/2" x 1-1/2" bolt, coarse thread	1	
				9/16" x 1-1/2" bolt, coarse thread	1	
				9/16" sae washer	1	
				1/2" x 5-1/2" bolt, coarse thread	2	
				1/2" sae washer	5	
				1/2" nyloc nut, coarse thread	2	
20	2171155	1	control arm bracket, front passenger side	55-07-5841 - 9/16" tab nut	1	77-5900
				2171179 - 1/2" tab nut	1	
				55-08-5841 - 1/2" tab nut	1	
				2171186 - 1/2" tab nut	1	
				1/2" x 2" countersunk bolt, coarse thread	2	
				1/2" x 1-1/2" bolt, coarse thread	1	
				9/16" x 1-1/2" bolt, coarse thread	1	
				9/16" sae washer	1	
				1/2" x 5-1/2" bolt, coarse thread	2	
				1/2" sae washer	5	
				1/2" nyloc nut, coarse thread	2	
28	66-13-5841	2	control arm, front upper	12mm x 90mm bolt, 1.75 pitch	1	77-5901
				12mm flat washer	2	
				12mm nyloc nut, 1.75 pitch	1	
				9/16" x 4" bolt, coarse thread	1	
				9/16" sae washer	2	
				55-23-5841 - 9/16" tab nut	1	
32	66-11-5841	1	control arm, front lower driver	9/16" x 4" bolt, coarse thread	2	77-5902
				9/16" sae washer	4	
				9/16" nyloc nut, coarse thread	2	
				5/8" x 4-1/4" bolt, coarse thread	1	
				5/8" sae washer	2	
				5/8" nyloc nut, coarse thread	1	
32	66-12-5841	1	control arm, front lower passenger	9/16" x 4" bolt, coarse thread	2	77-5902
				9/16" sae washer	4	
				9/16" nyloc nut, coarse thread	2	
				5/8" x 4-1/4" bolt, coarse thread	1	
				5/8" sae washer	2	
				5/8" nyloc nut, coarse thread	1	

Step	Part Number	Qty. per Kit	Description	New Attaching Hardware	Qty. per Bracket	Hardware Bag Number
40	55-17-5825	2	bump stop bracket, front	66-10-5825 - tab nut	1	77-5903
				3/8" x 1-1/4" bolt, coarse thread	1	
				3/8" sae washer	1	
40	780121	2	coil spring, front			
43	659584	2	shock cylinder, front Superide			77-87033
43	BE5-E189-T1	2	shock cylinder, front Bilstein			77-80018
43	980-24-887	2	shock cylinder, front Fox			
44	PR039-11	1	adjustable track bar, front			
46	55-33-5704	1	brake hose bracket, front driver	1/4" x 3/4" bolt, coarse thread	1	77-5903
				1/4" sae washer	1	
				1/4" nyloc nut, coarse thread	1	
46	55-34-5704	1	brake hose bracket, front passenger	1/4" x 3/4" bolt, coarse thread	1	77-5903
				1/4" sae washer	1	
				1/4" nyloc nut, coarse thread	1	
48	55-39-5704	1	brake hose bracket, front lower driver	adel hose clamp	1	77-5903
				1/4" x 3/4" bolt, coarse thread	1	
				1/4" sae washer	1	
				1/4" nyloc nut, coarse thread	1	
48	55-40-5704	1	brake hose bracket, front lower passenger	adel hose clamp	1	77-5903
				1/4" x 3/4" bolt, coarse thread	1	
				1/4" sae washer	1	
				1/4" nyloc nut, coarse thread	1	

REAR						
17	55-01-5841	1	control arm bracket, rear upper driver side	55-04-5841 - 9/16" tab nut	1	77-5904
				55-03-5840 - 1/2" tab nut	1	
				9/16" x 1-1/2" bolt, coarse thread	1	
				9/16" sae washer	3	
				1/2" x 1-1/2" bolt, coarse thread	1	
				1/2" sae washer	1	
				9/16" flange nut, coarse thread	1	
				9/16" x 4" bolt, coarse thread	1	
17	55-02-5841	1	control arm bracket, rear upper passenger side	55-04-5841 - 9/16" tab nut	1	77-5904
				55-05-5840 - 1/2" tab nut	1	
				9/16" x 1-1/2" bolt, coarse thread	1	
				9/16" sae washer	3	
				1/2" x 1-1/2" bolt, coarse thread	1	
				1/2" sae washer	1	
				9/16" flange nut, coarse thread	1	
				9/16" x 4" bolt, coarse thread	1	

Step	Part Number	Qty. per Kit	Description	New Attaching Hardware	Qty. per Bracket	Hardware Bag Number
21	2171156	1	control arm bracket, rear lower driver side	2171174 - 1/2" double tab nut	1	77-5904A
				55-05-5841 - 1/2" & 5/8" triple tab nut	1	
				1/2" x 1" countersunk bolt, coarse thread	2	
				1/2" x 1-1/2" bolt, coarse thread	2	
				1/2" sae washer	2	
				5/8" x 4-1/2" bolt, coarse thread	1	
				5/8" sae washer	1	
21	2171157	1	control arm bracket, rear lower passenger side	2171176 - 1/2" double tab nut	1	77-5904A
				55-06-5841 - 1/2" & 5/8" triple tab nut	1	
				1/2" x 1" countersunk bolt, coarse thread	2	
				1/2" x 1-1/2" bolt, coarse thread	2	
				1/2" sae washer	2	
				5/8" x 4-1/2" bolt, coarse thread	1	
				5/8" sae washer	1	
29	66-03-5841	2	control arm, rear upper	9/16" x 4" bolt, coarse thread	1	77-5905
				9/16" sae washer	2	
				9/16" nyloc nut, coarse thread	1	
30	66-14-5841	2	control arm, rear lower	9/16" x 4-1/2" bolt, coarse thread	1	77-5905
				9/16" sae washer	2	
				9/16" nyloc nut, coarse thread	1	
32	55-15-5704	2	bump stop bracket, rear	5/16" x 3/4" bolt, coarse thread	2	77-5904B
				5/16" sae washer	2	
				5/16" stover nut, coarse thread	2	
33	07-5702	2	bump stop, rear			
34	780123	2	coil spring, rear (4 door)			
34	780122	2	coil spring, rear (2 door)			
35	716242	1	Brkt, Track Bar, Rear	9/16" x 3-1/4" bolt, coarse thread	1	77-5904B
				9/16" sae washer	1	
				9/16" stover nut	1	
				1/2" x 1" bolt, coarse	1	
				1/2" sae washer	1	
				1/2" stover nut	1	
				1-1/4" OD x 1-5/8" sleeve	1	
				9/16" tab nut	1	77-5704F
				3/8" flange nut	4	
				3/8" x 3-1/4" x 3-1/4" round ubolt	2	

Step	Part Number	Qty. per Kit	Description	New Attaching Hardware	Qty. per Bracket	Hardware Bag Number
43	55-21-5704	1	brake hose bracket, rear driver	1/4" x 3/4" bolt, coarse thread	1	77-5904B
				1/4" sae washer	1	
				1/4" nyloc nut, coarse thread	1	
				1/4" x 1/2" self-tapping bolt	1	
				adel hose clamp	1	
43	55-22-5704	1	brake hose bracket, rear driver	1/4" x 3/4" coarse thread bolt	1	77-5904B
				1/4" sae washer	1	
				1/4" nyloc nut, coarse thread	1	
				1/4" x 1/2" self-tapping bolt	1	
				adel hose clamp	1	
53	55-32-5704	2	sway bar link, rear	01-5710 - 90 degree heim joint	1	700640
				01-60418 - bushing	1	
				24-5704 - sleeve	1	
				1/2" stover nut, fine thread	1	77-5712
				1/2" jam nut, fine thread	1	
				1/2" sae washer	1	
58	659587 or	2	shock cylinder, rear Superide			77-87033
58	BE5-E978-T0 or	2	shock cylinder, rear Bilstein			77-80018
58	980-24-888	2	shock cylinder, rear Fox			

KIT BREAKDOWN		
Kit Part Number	560	
Part Number	Qty.	Part Description
01-560	2	Coil Springs, Front
Kit Part Number	561	
Part Number	Qty.	Part Description
780123	2	Coil Springs, Rear (4 Door)
OR		
Kit Part Number	562	
Part Number	Qty.	Part Description
780122	2	Coil Springs, Rear (4 Door)
Kit Part Number	5900	
Part Number	Qty.	Part Description
2171154	1	Control Arm Bracket, Front Driver
2171155	1	Control Arm Bracket, Front Passenger
77-5900	1	Hardware Bag
Kit Part Number	5901	
Part Number	Qty.	Part Description
66-13-5841	2	Control Arm, Front Upper
77-5901	1	Hardware Bag
Kit Part Number	5902	
Part Number	Qty.	Part Description
66-11-5841	1	Control Arm, Front Lower Driver
66-12-5841	1	Control Arm, Front Lower Passenger
77-5902	1	Hardware Bag
Kit Part Number	5903	
Part Number	Qty.	Part Description
716243	2	Bump Stop Bracket, Front
55-33-5704	1	Brake Hose Bracket, Front Driver
55-39-5704	1	Brake Hose Bracket, Front Lower Driver
55-40-5704	1	Brake Hose Bracket, Front Lower Passenger
77-5903	1	Hardware Bag
Kit Part Number	5904	
Part Number	Qty.	Part Description
55-01-5841	1	Control Arm Bracket, Rear Upper Driver Side
55-02-5841	1	Control Arm Bracket, Rear Upper Passenger Side
2171156	1	Control Arm Bracket, Rear Lower Driver Side
2171157	1	Control Arm Bracket, Rear Lower Passenger Side
55-15-5704	2	Bump Stop Bracket, Rear
07-5702	2	Bump Stop, Rear
716242	1	Brkt, Track Bar, Rear
55-21-5704	1	Brake Hose Bracket, Rear Driver
55-22-5704	1	Brake Hose Bracket, Rear Driver
55-32-5704	2	Sway Bar Link, Rear
77-5904	1	Hardware Bag
77-5904A	1	Hardware Bag
77-5904B	1	Hardware Bag
700640	1	Hardware Bag
77-5704F	1	Hardware Bag
700640	1	Hardware Bag
77-5712	1	Hardware Bag

KIT BREAKDOWN		
Kit Part Number	5905	
Part Number	Qty.	Part Description
66-03-5841	2	Control Arm, Rear Upper
66-14-5841	2	Control Arm, Rear Lower
77-5905	1	Hardware Bag
Kit Part Number	5770	
Part Number	Qty.	Part Description
PR039-11	1	Adjustable Track Bar, Front
Kit Part Number	84047	
Part Number	Qty.	Part Description
659584	2	Shock Cylinder, Front Superide
659587	2	Shock Cylinder, Rear Superide
77-870033	1	Hardware Bag
Kit Part Number	84048	
Part Number	Qty.	Part Description
BE5-E189-T1	2	Shock Cylinder, Front Bilstein
BE5-E978-T0	2	Shock Cylinder, Rear Bilstein
Kit Part Number	84041	
Part Number	Qty.	Part Description
980-24-887	2	Shock Cylinder, Front Fox
980-24-888	2	Shock Cylinder, Rear Fox

FRONT INSTALLATION

1. NOTE: Save all factory components and hardware for reuse, unless noted.
2. Chock rear tires and place transmission in neutral. Raise front of vehicle with a jack and secure a jack stand beneath each frame rail behind the lower control arms. Ease the frame down onto the stands and place transmission in park.
3. Remove front tires and wheels.
4. Remove the front track bar.
5. Loosen but do not remove the upper and lower control arm bolts at the frame and axle.
6. Remove and discard the front sway bar links.
7. Disconnect the factory brake hose bracket at the frame.
8. Disconnect the ABS clip from the top inside of the shock tower.
9. Slide the axle vent hose down approximately 3" at the clamp on the driver's side frame rail, leave attached to frame.
10. On Rubicon models, the wiring loom for the locking differential is attached to the upper control arm, remove and discard the clip.

11. [Illustration 1] Carefully pry the factory brake line bracket from the rubber hose; do not damage the hose in the process.

1



12. Disconnect the front drive shaft at the axle, taking caution when the drive shaft is hanging to not damage the boot at the transfer case.

13. Remove and discard the front crossmember located under the front drive shaft that attaches to the transmission crossmember.

14. With the axle properly supported remove the control arms.

15. [Illustration 2] Using the appropriate cutting tool, cut the exhaust on the driver's side about 2.5"-3" behind the catalytic converter, then unbolt from the flange at the transmission crossmember and remove section from the vehicle.

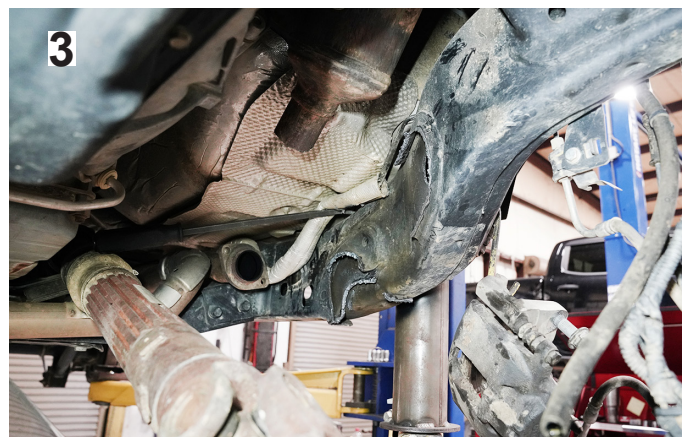
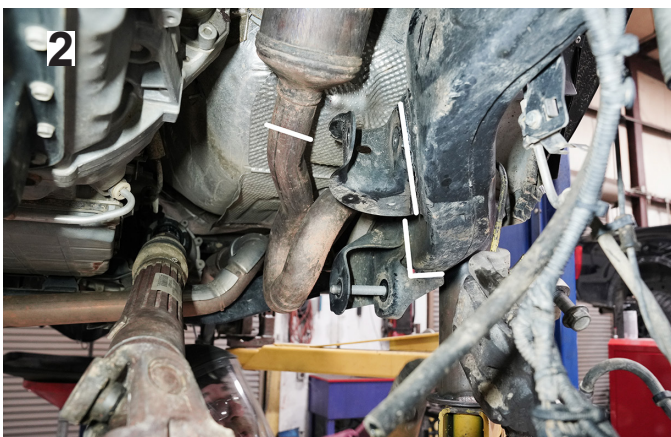

16. [Illustration 3] Using the appropriate cutting tool, cut the front upper and lower control arm mounts off of the frame. Make sure the brake lines located in the insulation above the brackets is not damaged during the removal of the brackets. Also take special care to not cut into the frame rail.



17. [Illustration 4] Grind the frame smooth, clean and then paint the exposed areas.
18. [Illustration 5] Locate the threaded hole on the bottom of the frame rail that the previously discarded crossmember was mounted to and drill out the threads to a 1/2".
19. [Illustration 6] Support the transmission crossmember and remove the two driver side bolts.
20. [Illustration 7] Position the new control arm bracket (2171154 driver side, 2171155 passenger side) on the frame, loosely secure it to the transmission crossmember using the supplied 1/2" x 5-1/2" bolts, washers, and nyloc nuts.



21. [Illustration 8] Install a supplied 1/2" x 2" countersunk bolt into the forward most hole and loosely secure it with the new tab nut (55-08-5841).
22. [Illustration 9] Install a supplied 1/2" x 2" countersunk bolt into the rearward most hole and loosely secure it with the new tab nut (2171179).
23. Tighten the four 1/2 bolts starting with the crossmember bolts then move to the countersunk bolts. (75)



24. [Illustration 10] Using the bracket as a template drill a 9/16" hole in the frame, locate the hole in the control arm bracket that is behind the upper control arm mount and drill through the frame.
25. [Illustration 11] Install the supplied 9/16" x 1-1/2" bolt and washer, secure using the supplied 9/16" tab nut (55-07-5841); tighten. (90)



26. [Illustration 12] Using the bracket as a template drill a 1/2" hole in the frame, locate the hole in the control arm bracket that is in front of the upper control arm mount and drill through the frame.
27. [Illustration 13] Install the supplied 1/2" x 1-1/2" bolt and washer, secure using the supplied 1/2" tab nut (2171186); tighten. (75)
28. Locate the new front upper control arms (66-13-5841), make sure the double adjuster and eye ring are threaded all the way in.
29. Holding the body of the control arm and the eye ring in a fixed position, turn the double adjuster to adjust the control arm eye to eye length to 31-3/8". This will be the starting point for installation, final adjustments may need to be made during alignment.
30. [Illustration 14 & 15] Install the assembled control arm into the control arm mount with the socket head bolts placed on the inside and facing down and secure with the supplied 9/16" x 4" bolt, washer and tab nut (55-23-5841); do not tighten.



31. Attach the control arm to the axle using the supplied 12mm x 90mm bolt, washer, and nyloc nut; do not tighten.
32. Locate the new front lower control arms (66-11-5841 driver side, 66-12-5841 passenger side), make sure the double adjuster and eye ring are threaded all the way in.
33. Holding the body of the control arm and the eye ring in a fixed position, turn the double adjuster to adjust the control arm eye to eye length to 34". This will be the starting point for installation, final adjustments may need to be made during alignment.
34. [Illustration 16] Install the assembled control arm into the control arm mount with the socket head bolts placed on the inside and facing down and and secure using the supplied 5/8" x 4-1/2" bolt, washer, and nyloc nut; do not tighten.
35. Attach the control arm to the axle using the supplied 9/16" x 4" bolt, washer, and nyloc nut; do not tighten.
36. Remove and discard the shock absorbers.
37. Lower the axle enough to remove the front coil springs.

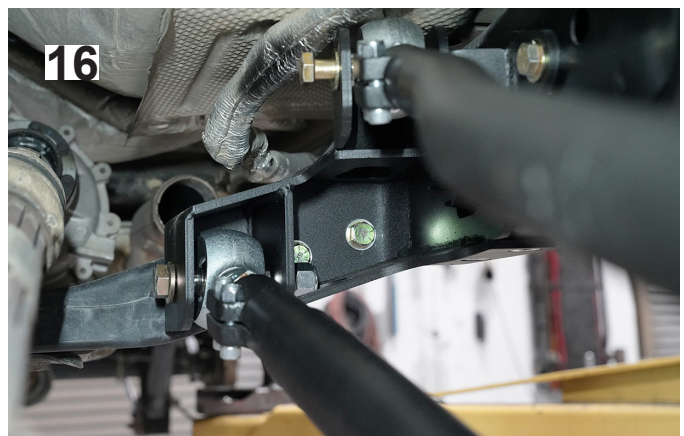

38. [Illustration 17] Mark the center of the lower coil seat, measuring from the rear of the coil seat to the front 1.91", then from the outside edge to the inside 1.54".
39. Drill a 3/8" hole on the mark.
40. Place the new bump stop (55-17-5825) into the new coil spring (780121).
41. Position the coil spring into upper coil tower, then onto the lower seat while holding the bump stop spacer in place.
42. [Illustration 18] Position the bump stop spacer over the drilled hole and secure using the supplied 3/8" x 1-1/4" bolt, washer, and tab nut (66-10-5800). (25)

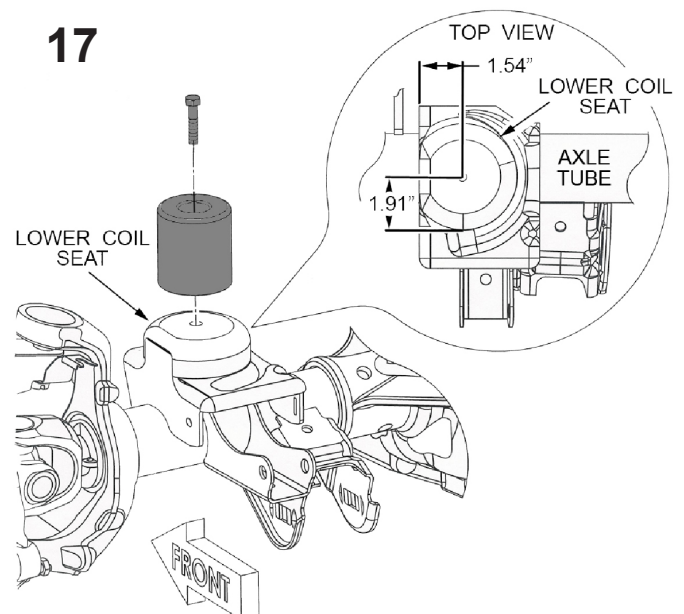

43. Install the new shock absorbers.
44. Locate the new track bar (PRO39-11) and set the eye to eye length to 32-7/8", final adjustments may be needed once the vehicle is on the ground.
45. Position the adjustable track bar in the mounts and secure with the factory hardware; do not tighten.
46. [Illustration 19] Attach the new upper brake hose bracket (55-33-5704 driver side, 55-34-5704 passenger side) to the factory brake hose using the supplied 1/4" x 3/4" bolt, washer, and nyloc nut. (6)

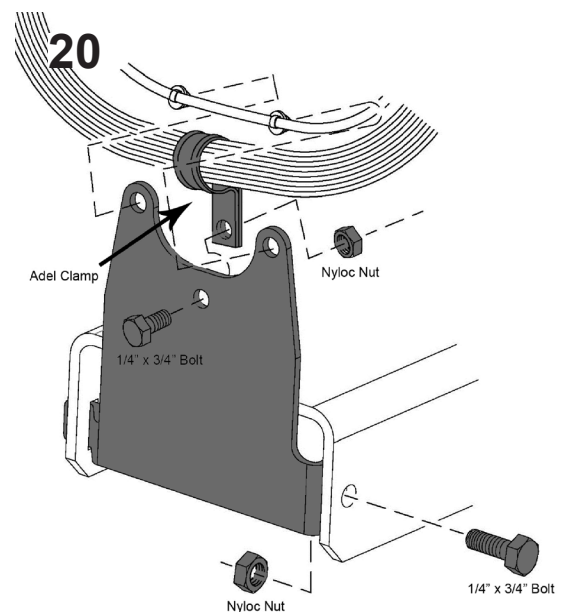
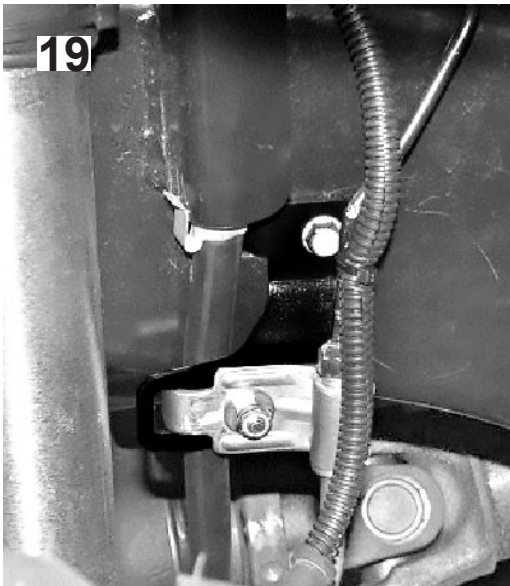

47. Carefully re-form the metal brake line and attach the new bracket to the factory location using the factory hardware. (6)
48. [Illustration 20] Attach the new lower brake hose bracket (55-39-5704 driver side, 55-40-5704 passenger side) to the axle using the supplied 1/4" x 3/4" bolt, washer, and nyloc nut. (6)
49. [Illustration 20] Place the adel clamp on the brake hose then attach the clamp to the new bracket using the supplied 1/4" x 3/4" bolt, washer, and nyloc nut.
50. [Illustration 20] Attach the ABS line to the new bracket using the factory clips.
51. Remove the rear sway bar links and install them on the front of the vehicle by attaching the swivel end of the sway bar link to the sway bar body with the stud facing inboard and secure the using the factory hardware. NOTE: Rubicon models must install kit # 5712 per separate instructions.
52. Attach the eye ring to the axle against the inboard side of the mounting tab. The factory bolt installs from the outboard side through the tab then the eye ring. Place one supplied 0.5" ID thick washer on the factory bolt and tighten. (75)
53. Connect the front drive shaft to the axle using the factory hardware. (81)
54. Reinstall tires and wheels and tighten the lug nuts.

55. When the tires and wheels are installed, always check for and remove any corrosion, dirt, or foreign material on the wheel mounting surface, or anything that contacts the wheel mounting surface (hub, rotor, etc.). Installing wheels without the proper metal-to-metal contact at the wheel mounting surfaces can cause the lug nuts to loosen and the wheel to come off while the vehicle is in motion.
56. Retighten lug nuts at 500 miles after any wheel change, or anytime the lug nuts are loosened. Failure to do so could cause wheels to come off while vehicle is in motion.
57. Lower vehicle to the floor.

REAR INSTALLATION

1. Chock rear tires and place transmission in neutral. Raise rear of vehicle with a jack and secure a jack stand beneath each frame rail in front of the lower control arms. Ease the frame down onto the stands and place transmission in park. Chock the front tires.
2. Remove front tires and wheels.
3. Disconnect the factory track bar from the axle and loosen the frame attachment point.
4. Remove the rear shock absorbers.
5. Pry the bump stops from the mounting cups.
6. Unbolt the wire bracket holding the rear emergency brake cable to the body.
7. On Rubicon models, unclip the wiring loom from the bracket bolted to the top of the differential cover and remove the bracket.
8. Disconnect the rear drive shaft from the axle, taking caution when the drive shaft is hanging to not damage the boot at the transfer case.
9. Make sure the axle is secured and remove the upper and lower link arms from the vehicle.
10. [Illustration 21] Supporting the fuel tank remove the mounting hardware.
11. [Illustration 22] Slowly lower the tank down enough to disconnect the fuel lines at the front and rear of the tank and all electrical lines.
12. [Illustration 23] Carefully remove the fuel tank from the vehicle and cover all fuel tank openings and lines with a protective covering. Cover all open fuel lines on vehicle with a protective covering.



13. [Illustration 24] Using the appropriate cutting tool, cut the rear upper and lower control arm mounts off of the frame. Take special care to not cut into the frame rail.



14. [Illustration 25] The body mount located in front of the new rear upper control arm bracket must have the legs of the bracket trimmed to be flush with the bottom of the new control arm mount; the lip of the rear leg of the body mount must also be removed.
15. [Illustration 25] Mark the body mount and remove the new control arm bracket.
16. Trim body mount legs with the appropriate cutting tool and paint exposed areas.
17. [Illustration 26] Place the new rear upper control arm bracket (55-01-5841 driver side and 55-02-5841 passenger side) on the frame behind the body mount located in front of the rear wheelwell. Line the holes up in the side and bottom of the frame and loosely secure using the supplied hardware with the 9/16" x 1-1/2" bolt, washer, and nut on the side rear hole and the 1/2" x 1-1/2" bolt, washer, and tab nut (55-03-5840 driver side and 55-05-5840 passenger side).

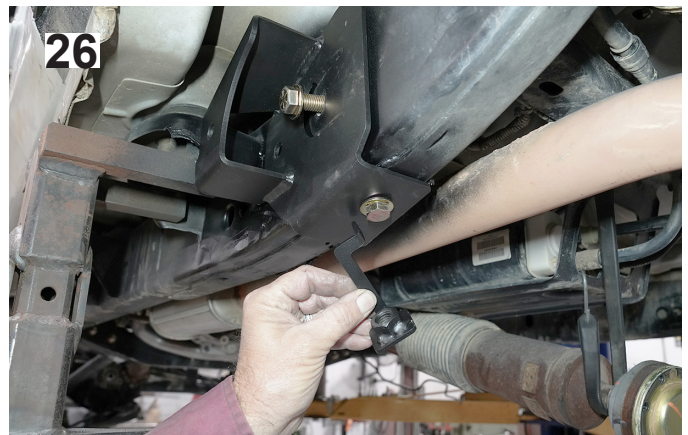

18. Tighten the 9/16" bolt. [13/16"] (110)
19. Tighten the 1/2" bolt. [3/4"] (80)
20. [Illustration 27] Using the upper bracket as a template, drill a 9/16" hole through the control arm mount into the frame.
21. [Illustration 28] Position the new rear lower control arm bracket (2171156 driver side, 2171157 passenger side) on the frame 5/8" behind the body mount located at the front of the rear door.



22. [Illustration 29] Clamp the bracket tightly to the frame and using the bracket as a template drill the top two holes to 1/2" and the control arm mounting hole to 5/8".



23. [Illustration 30] Between the body mount legs, measure forward 1" from the rear leg and up 2" from the bottom of the frame and mark.

24. [Illustration 31] Drill a 1.75" hole in the outer side of the frame rail for the tab nuts to be inserted.

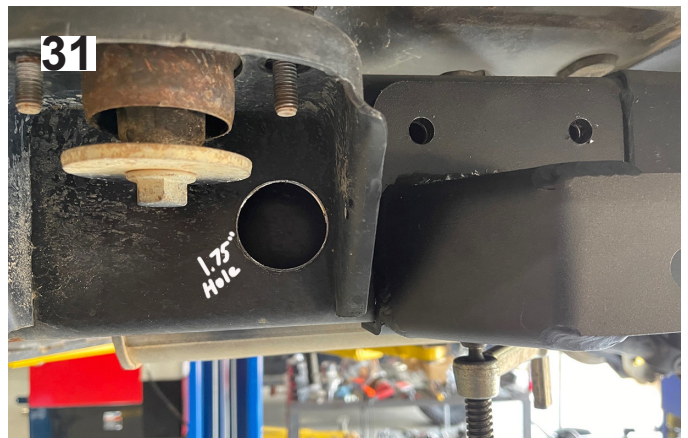
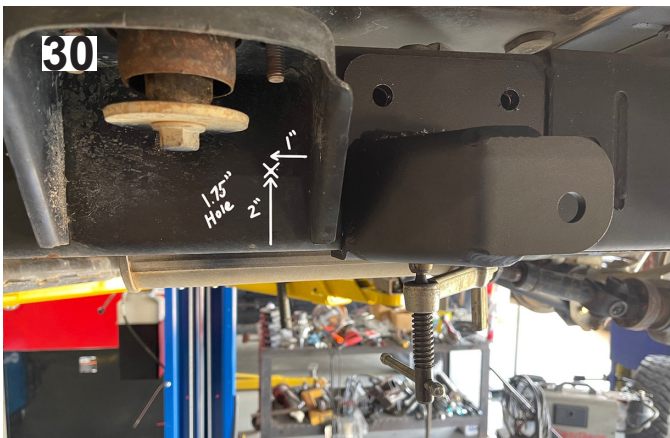

25. [Illustration 32] Secure the bracket through the top two holes using the supplied 1/2" bolts, washers, and new tab nut (55-05-5841 driver side, 55-06-5841 passenger side) start the 5/8" bolt through the control arm mount but do not tighten; tighten the 1/2" bolts. [9/16"] (80)

26. With the bracket tightly fastened to the frame, using the bracket as a template, drill the two bottom mounting holes to 1/2".

27. [Illustration 33] Install the new supplied 1/2" countersunk bolts and secure them with the new tab nut (2171174 driver side, 2171176 passenger side). (70)



28. Reinstall the fuel tank in reverse order from removal; raise into place, connect the fuel lines and electrical connections, and secure to frame using factory hardware.

29. [Illustration 34] Install the new upper control arms (66-03-5841) into the frame brackets using the supplied 9/16" bolts, washers, and tab nut (55-04-5841); making sure the pinch bolts are to the outside and the bolt head pointing downward. [13/16"] (100)



30. [Illustration 34] Install the new lower control arms (66-14-5841) into the frame brackets using the supplied 5/8" bolts, washers, and previously installed tab nut; making sure the pinch bolts are to the outside and the bolt head pointing downward. [15/16"] (150)

31. Connect the control arms to the axle using the supplied 9/16" x 4" bolts, washers, and nuts on the upper control arms and the 9/16" x 4-1/2" bolts, washers, and nuts on the lower control arms.

32. Install the new rear bump stop pad (55-15-5704) onto the rear axle bump stop pad using the supplied 5/16" bolts, washers, and nuts. [1/2"] (15)

33. Install the new rear bump stop (07-5702) into the factory mounting cup on the frame.

34. Install the new coil springs (780123 4-door, 780122 2-door), make sure they are rotated to be correctly positioned in the coil seats.

35. [Illustration 35] Install the new rear track bar bracket (716242) on the axle over the factory mount.

36. [Illustration 35] Insert the supplied 9/16" bolt through the new bracket and the factory mount. Do not install the sleeve and the nut at this time, this is just for alignment purposes.

37. [Illustration 36] Install the two supplied 3/8" ubolts that clamp the bracket to the axle and secure with the supplied flange nuts; tighten. [9/16"] (35)

38. [Illustration 36] Using the factory bracket as a template drill a 1/2" hole through the outside of factory track bar bracket, do not drill into the previously installed 9/16" bolt.

39. [Illustration 36] Install the supplied 1/2" bolt, washer, and nut through the newly drilled hole, remove the 9/16" and tighten 1/2" hardware. [3/4"] (80)

40. [Illustration 36] Install the 9/16" bolt, placing the new sleeve inside the factory bracket and then secure using the supplied washer and tab nut (12-5700); tighten. [13/16"] (110)

41. [Illustration 35] Connect the factory track bar to the new bracket using the supplied hardware, do not tighten.

42. A plastic clip attached the metal brake line to the frame needs to be removed and discarded.

43. Attach the rear brake hose bracket (55-21-5704 driver side and 55-22-5704 passenger side) to the factory frame location using the factory hardware making sure to engage the alignment tab into the hole in the frame.

44. Attach the brake hose to the bracket using the supplied 1/4" bolt, washer, and nut, installing the nut from the outside and place the nut on the nut side.

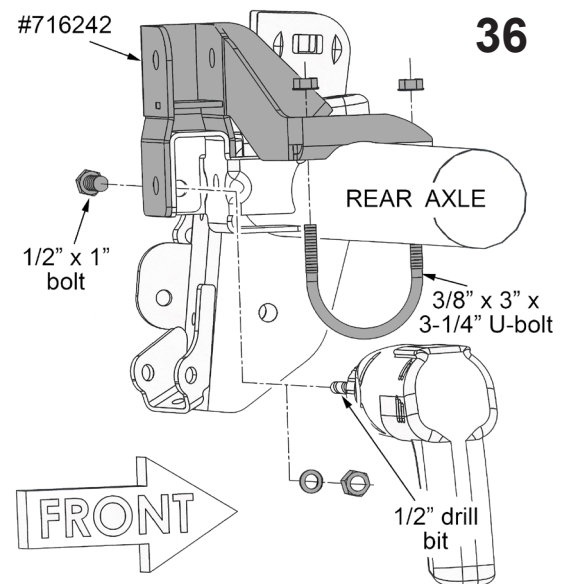
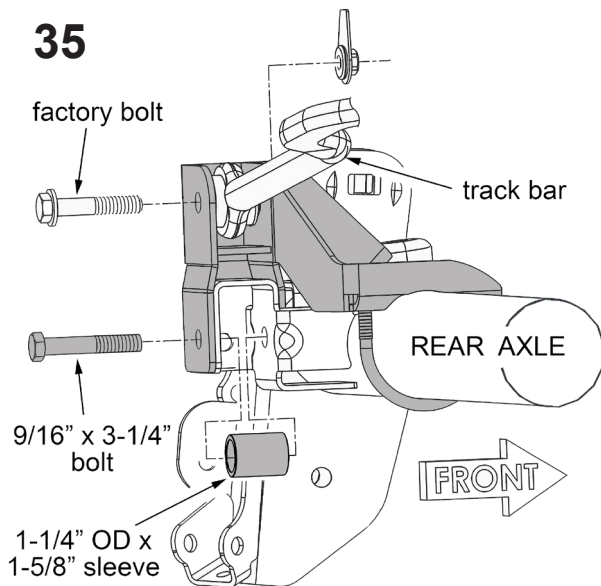

45. Carefully re-form the metal line so that it runs along the upper edge of the frame. The supplied adel clamps (one per side) hold the reformed metal brake lines tight against the frame to prevent from potentially making contact with the sway bar links.
46. 2 Door Models ONLY. The emergency brake cables are routed beneath the vehicle body (along the transmission tunnel), above the frame crossmember then down to each wheel. Detach the two emergency brake cables from the axle and reroute them to below the frame crossmember and reattach the cables to the axle.
47. [Illustration 37] 4 Door Models ONLY (steps 47-51). The emergency brake cables are routed beneath the vehicle body (along the transmission tunnel), above the frame crossmember then through a wire hanger bracket that is attached to the floorboard. Detach the two emergency brake cables from the wheel hanger bracket then detach the wire hanger bracket from the floorboard.
48. [Illustration 37] Position the wire hanger bracket at the center of the frame crossmember. Using the wire hanger bracket as a template, mark the location for the two mounting holes to be drilled. Drill the holes to 13/64\".
49. [Illustration 37] Attach the wire hanger bracket to the frame crossmember using the supplied 1/4\" self-tapping bolts and tighten. [7/16\"]
50. [Illustration 37] On each side disconnect the emergency brake cable at the axle and reroute them to below the frame crossmember.
51. Insert each brake cable into the relocated wire hanger bracket then reconnect the brake cables to the axle.
52. Drill out the holes in the ends of the sway bar to 1/2\".
53. Lubricate the supplied bushings and sleeves with a light grease, then install the bushings and sleeves into the bottom of the new sway bar links (55-32-5704).

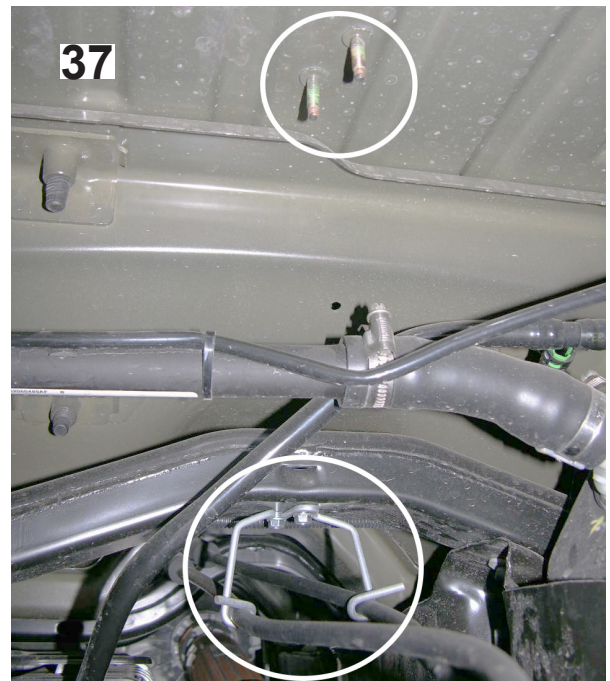

54. Apply anti-seize to the stud end of the sway bar links. Install the 1/2" jam nut onto the link then the 90° swivel end. Adjust the swivel end to reach the center-to-center measurement of 11-1/4" then tighten the jam nut.
55. From the factory the sway bar links mount outboard of the sway bar body with their upper studs facing inboard, install the new links in the same direction.
56. Place a 1/2" washer on the sway bar link stud, then insert the stud into the sway bar body, then place another washer and nut on the stud; tighten. [3/4"] (80)
57. Connect the links to the axle and secure using the factory hardware; tighten. [18mm] (75)
58. Install the new shock absorbers using the factory hardware, placing the shock body at the axle. [18mm] (75)
59. [Illustration 38] 4 Door Models ONLY (steps 59-63). On the evaporative canister located on the driver side between the transfer case and rear axle, loosen the rear single bolt but do not remove.
60. [Illustration 38] Remove the front two bolts.
61. [Illustration 38] Measure from the center of the inside hole towards the center of the vehicle 2", then to the rear of the vehicle 9/16", mark, and drill a 5/8" hole through the bracket only....NOT INTO THE CROSSMEMBER.
62. [Illustration 38] Pivot the bracket to the driver side of the vehicle so the factory inside hole is now over the outside hole position and reinstall the factory bolts.
63. [Illustration 38] Insert the remaining factory bolt through the newly drilled hole and tighten front and rear bolts. [18mm] (75)

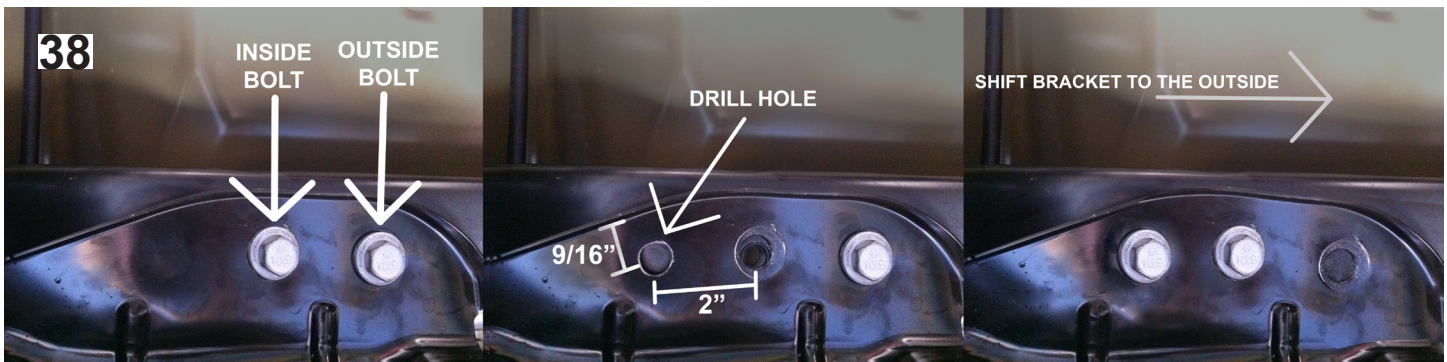

64. Reconnect the driveshaft and secure using the factory hardware. (81)
65. Reinstall the tires and wheels and lower vehicle to the ground.

FINAL CHECKS

1. Remove jack stands and lower vehicle to the floor and torque lug nuts.
2. Tighten the front and rear track bars at both ends. (115)
3. Tighten the front upper control arms at the frame. [13/16"] (115)
4. Tighten the front upper control arms at the axle. [18mm] (75)

5. Tighten the front lower control arms at the frame. [15/16"] (150)
6. Tighten the front lower control arms at the axle. [13/16"] (115)
7. Tighten the rear upper control arms at the frame and axle. [13/16"] (115)
8. Tighten the rear lower control arm at the frame. [15/16"] (150)
9. Tighten the rear lower control arm at the axle. [13/16"] (115)
10. Tighten the shock absorbers. (55)
11. Verify that the tires (not the steering wheel) are pointed straight ahead, then position a plumb bob against the inside edge of the frame and measure the distance between the line of the plumb bob and the inside edge of the wheel. Record this measurement and repeat on the other side.
12. Subtract the two measurements from each other and divide them by 2. This is the measurement that the track bar will need to be adjusted to get it centered. Note that no more than 3/8" of the threads can be exposed once the jam nut is tightened.
13. Disconnect the lower end of the track bar from the axle and make the appropriate adjustments.
14. Tighten the jam nut firmly then reattach the track bar to the axle. (115)
15. The steering wheel must be centered prior to moving the vehicle or an electronic stability program sensor may be activated resulting in a dash light and a warning chime that requires 20 plus ignition key cycles to clear.
16. Start engine and steer wheels straight ahead. Loosen the nuts on the drag link adjustment sleeve then rotate adjuster until steering wheel is centered.
17. In order to achieve proper adjustment sleeve clamping force, clamp assemblies must have the open side of each clamp aligned with the slot in the threaded adjustment sleeve. Improper positioning and bolt torque will promote linkage deflection which may contribute to tire shimmy. Tighten bolts. (26)
18. With the vehicle on the ground, check all components for proper operation and clearances. Pay special attention to the clearance between the tires / wheels, brake hoses, wiring, etc. Check tire/wheel clearance with the fenders/bumper as well as with the steering knuckle.
19. Realign vehicle to factory specifications. It is necessary to have a proper and professional wheel alignment performed by a certified alignment technician.
20. Re-adjust headlights to proper setting.
21. Activate four wheel drive system and check for proper engagement.
22. Install the **Warning to Driver** decal on the inside of the windshield or dash within the Driver's view.

IMPORTANT MAINTENANCE INFORMATION

It is the ultimate buyer's responsibility to have all bolts / nuts checked for tightness after the first 100 miles and then every 1000 miles. The steering, suspension and driveline systems, plus wheel alignment should be inspected by a qualified professional mechanic at least every 3000 miles.

LIMITED LIFETIME WARRANTY / WARNINGS

Your SUPERLIFT® product is covered by the Limited Warranty explained below that gives you specific legal rights. This limited warranty is the only warranty SUPERLIFT® makes in connection with your product

purchase. SUPERLIFT® neither assumes nor authorizes any retailer or other person or entity to assume for it any other obligation or liability in connection with this product or limited warranty.

SUPERLIFT, LLC, LIMITED LIFETIME WARRANTY

What is covered? Subject to the terms below, SUPERLIFT® will repair or replace its products found defective in materials or workmanship for so long as the original purchaser owns the vehicle on which the product was originally installed. Your warranter is SUPERLIFT, LLC, doing business as SUPERLIFT® Suspension Systems ("SUPERLIFT®").

What is not covered? Your SUPERLIFT® Limited Warranty does not cover products SUPERLIFT® determines to have been damaged by or subjected to:

- Alteration, modification or failure to maintain.
- Normal wear and tear (bushings, rod ends, etc.). Scratches or defects in product finishes (powder coating, plating, etc.).
- Damage to, or resulting from, the vehicle's electronic stability system, related components or other vehicle systems.
- Racing or other vehicle competitions or contests. Accidents, impact by rocks, trees, obstacles or other aspects of the environment.
- Theft, vandalism or other intentional damage.

Remedy limited to repair or replacement. The exclusive remedy provided hereunder shall, upon SUPERLIFT's inspection and at SUPERLIFT's option, be either repair or replacement of the product covered under this Limited Warranty. Customers requesting warranty consideration should contact SUPERLIFT® by phone (1-800-551-4955) to obtain a Returned Goods Authorization number. All removal, shipping and installation costs are customer's responsibility.

If a replacement part is needed before the SUPERLIFT® part in question can be returned, you must first purchase the replacement part. Then, if the part in question is deemed warrant-able, you will be credited / refunded.

OTHER LIMITATIONS - EXCLUSION OF DAMAGES - YOUR RIGHTS UNDER STATE LAW

- Neither SUPERLIFT® nor your independent SUPERLIFT® dealer are responsible for any time loss, rental costs, or for any incidental, consequential or other damages you may have.
- This Limited Warranty gives you specific rights, and this is the only warranty SUPERLIFT® makes in connection with your product purchase. You may also have other rights that vary from state to state. For example, while all implied warranties are disclaimed herein, any implied warranty required by law is limited to the terms of our Limited Lifetime Warranty as described above. Some states do not allow limitations of how long an implied warranty lasts and / or do not allow the exclusion or limitation of incidental or consequential damages, so the limitations and exclusions herein may not apply to you. SUPERLIFT® neither assumes nor authorizes any retailer or other person or entity to assume for it any other obligation or liability in connection with this product or Limited Warranty.

IMPORTANT PRODUCT USE AND SAFETY INFORMATION / WARNINGS

As a general rule, the taller a vehicle is, the easier it will roll over. Offset, as much as possible, what is lost in rollover resistance by increasing tire track width. In other words, go "wide" as you go "tall"; always use as wide a tire and wheel combination as feasible to enhance vehicle stability. We strongly recommend, because of rollover possibility, that the vehicle be equipped with a functional roll bar and cage system. Seat belts and shoulder harnesses should be worn at all times. Avoid situations where a side rollover may occur.

Generally, braking performance and capabilities are decreased when significantly larger / heavier tires and wheels are used. Take this into consideration while driving. Also, changing axle gear ratios or using tires that are taller or shorter than factory height will cause an erroneous speedometer reading. On vehicles equipped with an electronic speedometer, the speed signal impacts other important functions as well. Speedometer

recalibration for both mechanical and electronic types is highly recommended.

Do not add, alter, or fabricate any factory or aftermarket parts to increase vehicle height over the intended height of the SUPERLIFT® product purchased. Mixing component brands is not recommended.

THANKS for choosing SUPERLIFT...

For questions, technical support and warranty issues relating to this SUPERLIFT products, please contact SUPERLIFT directly.

**SUPERLIFT SUSPENSION
300 Huey Lenard Loop Rd.
West Monroe, Louisiana 71292
Phone: (318) 397-3000
Sales / Tech: (800) 551-4955
Fax: (318) 397-3040
SUPERLIFT.COM**