

Installation Instructions

Eibach Inc. 264 Mariah Circle Corona, CA 92879
USA Tech Support 800-507-2338 ext. 114



PRO-TRUCK COILOVER 2.0: E86-59-009-01-20

2024+ Lexus GX 550

Notes

(Disclaimer)

Check OEM for updated torque spec during install.

Out of the box coil-over height is set to be level with OE rear height(OE spring)

Kit Contents

Description	Part Number	Quantity
Front Coilover	82137.9003	2
2.0 Spanner Wrench	ETCO2.0	1

Installation Notes

Read all instructions before beginning installation

- Only qualified mechanics experienced in the installation and removal of suspension components should perform this installation.
- Use of a hoist and screw jack is highly recommended and will substantially reduce installation time.
- Never work on or under a vehicle unless it is properly supported by safety stands and wheels are blocked.
- Never use impact wrenches or impact guns to install or remove shock absorber piston components, shafts and Piston rod nuts.
- All Eibach springs should be installed with the Eibach logo right-side-up. All original stock spring isolators and dampers should be retained from the stock springs when installing Eibach PRO-LIFT springs.
- After Installation, inspect and adjust the following: Wheel Alignment; tire/wheel fender clearance when using aftermarket wheels or tires; brake line clearance and attachments; anti-lock-brake system sensors.
- Tire Rotation: In order to increase the life of your tires, it is recommended to rotate yours tires every 3,000 miles.

FRONT INSTALLATION



Step 1. Raise the vehicle on a suitable hoist and support it with the proper safety equipment. Use a 21mm socket to remove both front wheels. **Note:** Never work on or under a vehicle that is not supported by the proper safety equipment.

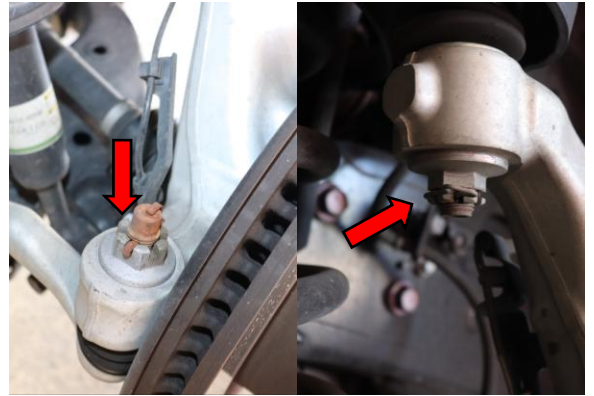

Step 2. Remove cotter pins from the castle nuts at the upper ball joint and tie rod ball joint.

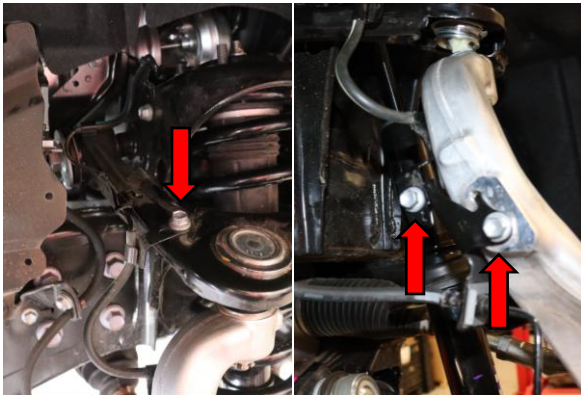

Step 3. Remove three 12mm bolts securing brake line and wheel speed sensor harness brackets.

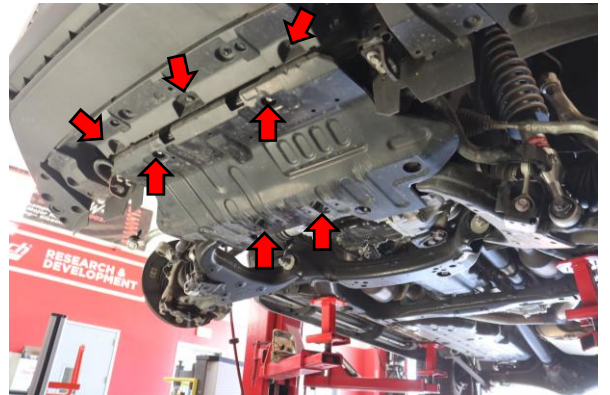

Step 4. Remove factory skid plate 4x 12mm bolts 2x 10mm bolts and 1 plastic clip to remove cover.

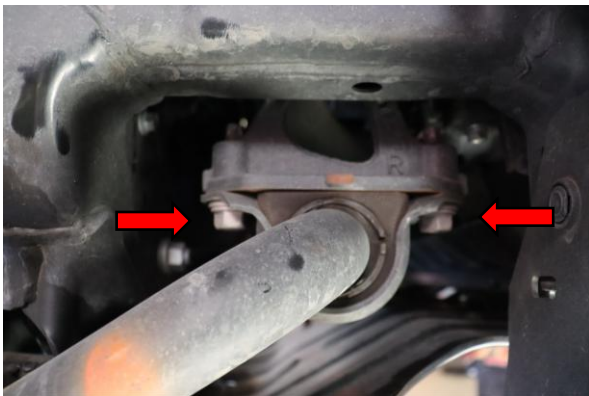

Step 5. Remove sway bar bracket hardware 4x 17mm

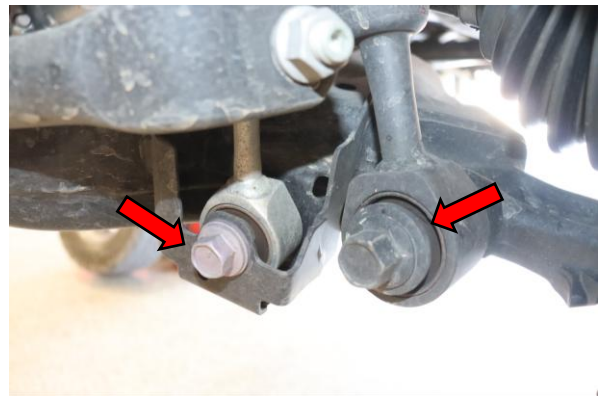

Step 6. Remove 19mm bolt securing the sway bar end link to the lower control arm. Remove lower shock bolt using 22mm socket but do not remove shock from mount

FRONT INSTALLATION

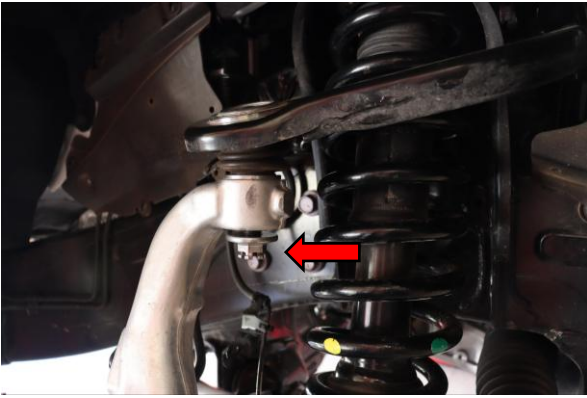

Step 7. Loosen, but do not remove the 19mm nut securing the spindle to the upper control arm. Use a hammer against the flat portion of the spindle to shock the upper ball joint and allow it to lift out of the spindle.



Step 8. Use a strap and secure the spindle to the frame to prevent damage to the axle CV joints.



Step 9. Use a pry bar against the spring coils and the upper control arm to give the upper ball joint slack in the spindle. While holding pressure on upper control arm, remove 19mm upper ball joint. Slowly allow upper control arm to rotate up and away from spindle. Allow spindle to rest against installed strap.

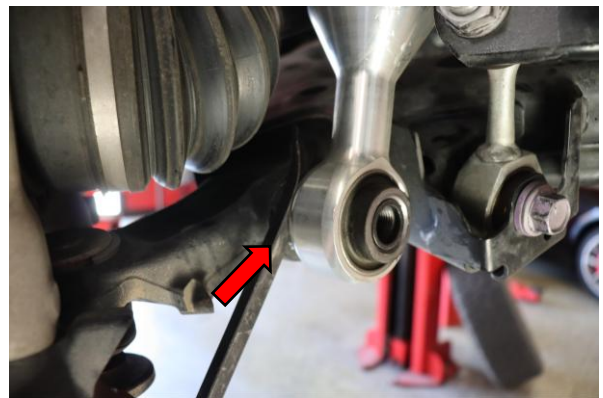

Step 10. Use prybar to remove lower shock from mount.

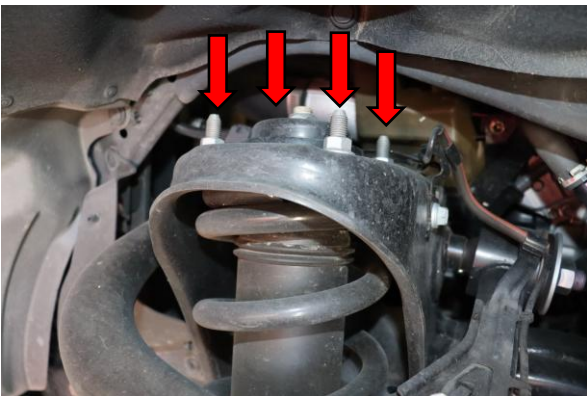

Step 11. Remove the four 14mm top hat nuts securing shock assembly to the frame.



Step 11. Remove OE shock from vehicle.

FRONT INSTALLATION



Step 12. Allow lower control arm to drop down slightly and rotate the bottom of the shock assembly toward the outside of the truck.



Step 13. Lower the shock assembly down and out of the upper control arm and remove shock assembly from the truck.



Step 14. Install the new coilover.

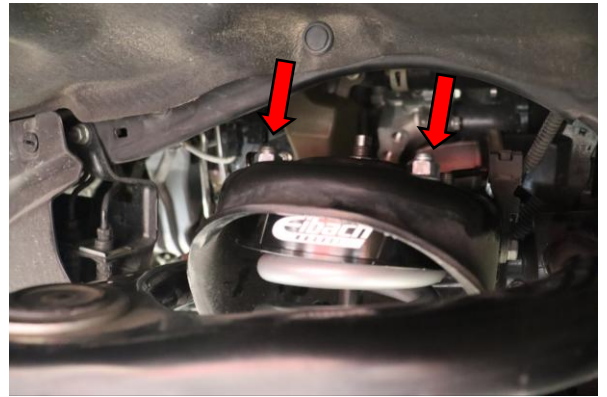

Step 15. Start 14mm hardware to hold coilover shock up during install but do not fully tighten.

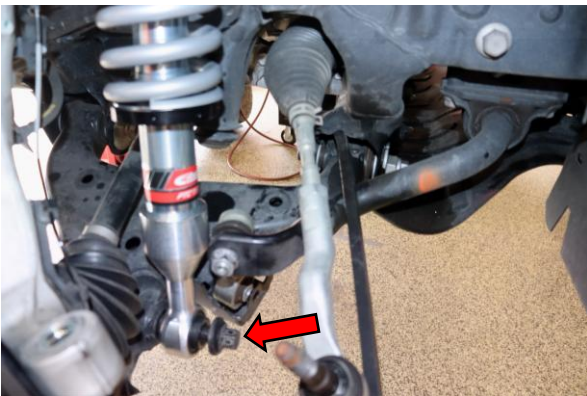

Step 16. Install the lower shock mounting bolt. Install 22mm nut on opposite side and tighten to factory specification (195 ft-lb)



Step 17. Use a pry bar against upper control arm and spring coil to lower the upper control arm into the spindle. Install 19mm nut onto the ball joint finger tight and remove pry bar. Remove the strap supporting the spindle installed on step 8.

FRONT INSTALLATION

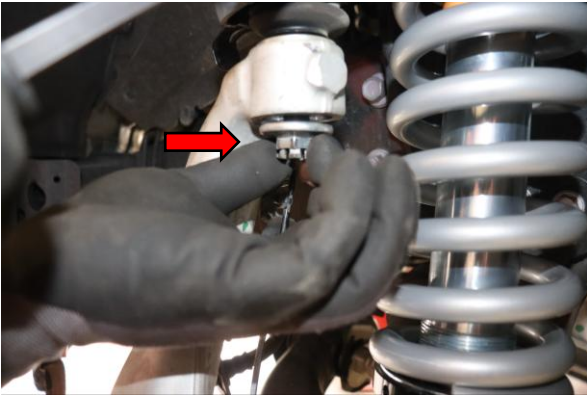

Step 18. Install 19mm hardware for upper ball joint to spindle and tighten to factory specification (92 ft-lb).

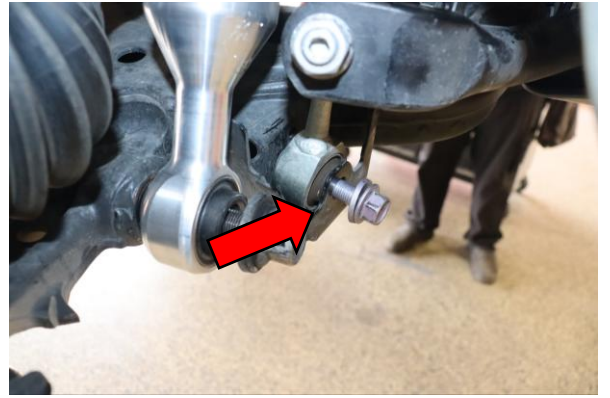

Step 19. Install 19mm bolt securing sway bar end link to the control arm. Tighten to factory specification (110 ft-lb)

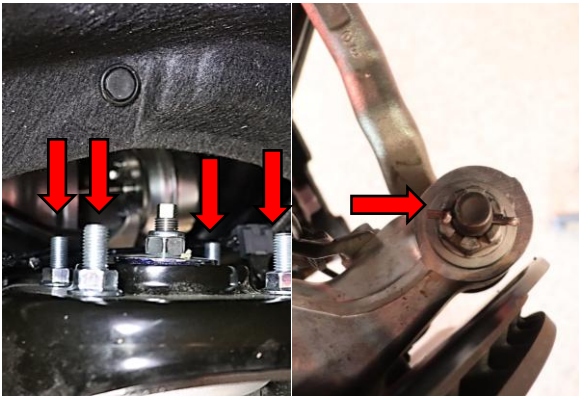

Step 20. Install 24mm hardware outer tie rod ball joint into the spindle (89 ft-lb). Tighten top hat to frame mounting hardware 4x from step 15. Tighten to factory specification (60 ft-lb)

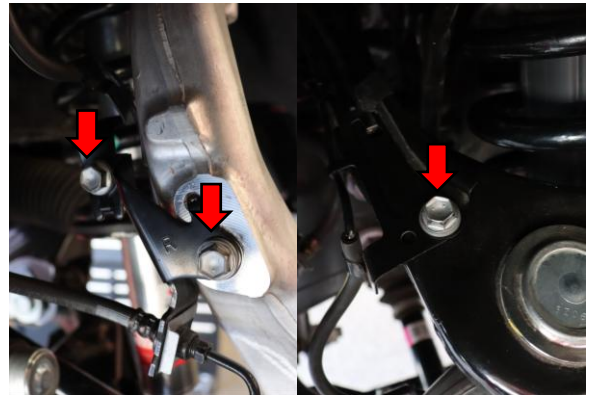

Step 21. Install three 12mm bolts securing the brake line and wheel speed wiring harness. Tighten to factory specification. (75 in-lb)

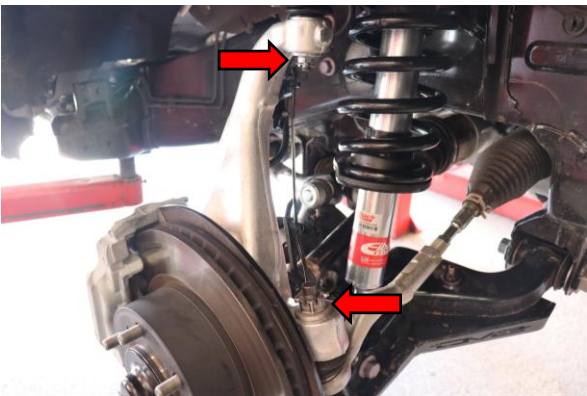

Step 22. Reinstall OE cotter pin in upper ball joint and install new cotter pin in outer tie rod end ball joint.

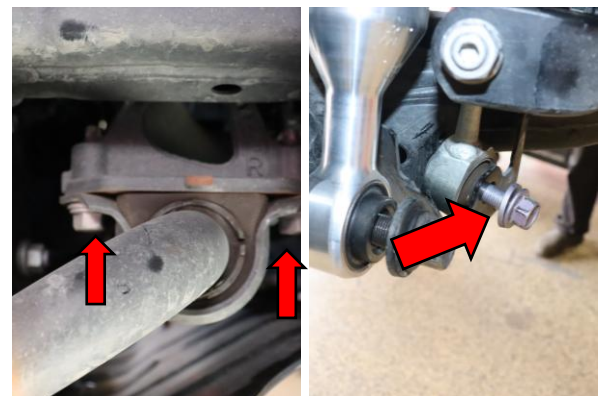

Step 23. Install sway bar bracket hardware 4x 17mm and torque to factory specification (66 ft-lb). Install sway bar end links hardware 19mm and torque to factory specification (110 ft-lb)

FRONT INSTALLATION

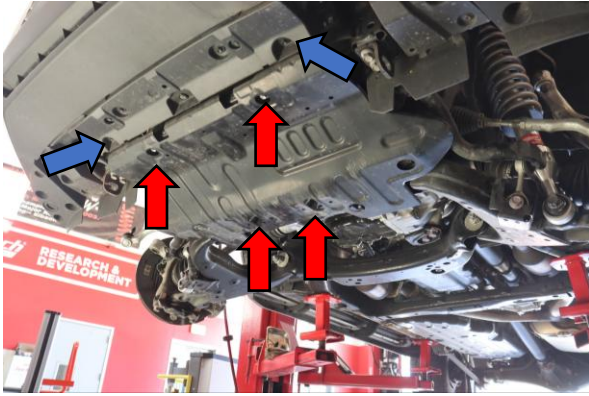

Step 24. Install factory skid plate. 10mm x2 (Blue arrows 66 IN-lb) 12mm x4 (red arrows (21 ft-lb)



Step 25. Install both front wheels. Use 21mm to torque lug nuts to factory specification. (97 ft-lb) when vehicle is on ground.

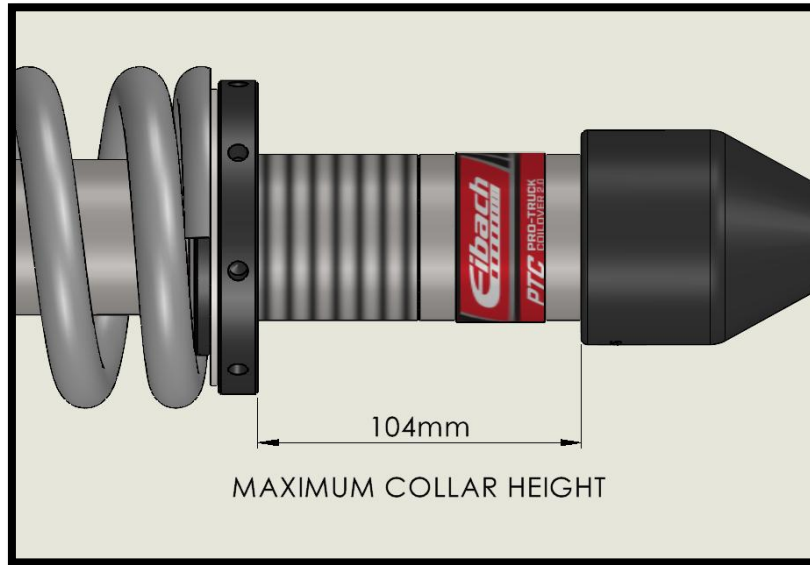

NOTE: DO NOT GO ABOVE A SPRING COLLAR HEIGHT OF 104mm FROM BOTTOM OF COLLAR TO BASE, AS SHOWN OR ELSE DAMAGE TO THE SHOCK AND SUSPENSION WILL OCCUR

Step 26. Out of box spring collar height 70mm(2 3/4in) may get front level with factory rear springs but each vehicle may vary some. If you are installing F31-59-009-01-RA with kit E86-59-009-01-20 a spring collar height of 100mm(3 15/16 in) may get front level with Eibach rear springs but every vehicle may vary some. **Note: If you have larger than stock wheels and tires, the ride height will be increased. Due to the sensitivity of weight of these vehicles, weight distribution may change ride heights, additional pre-load may need to be added to compensate.**