

X-Joint XL Performance Upper Arm Instructions

Ford F-150 2wd/4wd 2009-2014

Always inspect your suspension after off-roading and at your routine service intervals. Use of products sold by Camburg Engineering is at the consumer's own risk. Proper installation and proper use of all products must be followed for optimal safety and performance. Installing most suspension products will raise the center of gravity of the vehicle and can increase the susceptibility to a rollover and alter the handling characteristics. Camburg Engineering products may void aspects of the vehicles warranty. Camburg Engineering reserves the right to change the design, material or specifications of any product without assuming any obligation to modify any product previously manufactured and without prior notice. Every effort has been made to avoid printing errors and specifications. By purchasing, installing and/or using these products you are accepting these stated conditions and accept all liability and responsibility.



Warranty Information
Scan or Click QR Code

Parts Supplied

QTY	Description	ID
8	Polyurethane Pivot Bushings	3
4	7/8" OD x 9/16" ID x 2.50" L Sleeves	4
4	90 deg. Zerk Grease Fittings (self tapping)	5
2	Grease Zerk Fitting (straight)	6
2	M14 Washers	7
2	M14 x 1.50 Castle Nuts	8
2	Cotter Pins	9
2	X-Joint Cover Caps (press-on)	10
2	X-Joint Cover Cap O-rings	11
1	#30 x 10" Fishing Line (for cap install only)	
4	Bushing Grease Packets	
4	Camburg 8.5" Stickers	

* REFER TO EXPLODED CAD DRAWING ON *
* OTHER SIDE FOR PARTS REFERENCE NUMBERS *



Thanks for purchasing a set of our Camburg X-Joint XL performance upper arms for your vehicle. Please follow all instructions. If you are not installing these yourself have a qualified shop do so. These arms are designed for 1-3" of lift from coilovers and to be used with stock OEM spindles or Camburg performance spindles. These are NOT designed to be used with cheap spacer type lifts. Make sure to check the parts list to make sure you have every component prior to starting. Camburg Engineering has made every attempt to insure you receive the highest quality components in the most complete manner. This is a guide to help you through the process with recommended torque specs. It's your responsibility to ensure parts are being installed correctly using the correct tools and procedures. We recommend reviewing a service manual for more details.

Tools & Supplies Required

Eye protection | Jack | Jack Stands | Needle Nose Pliers
2-3 lb. Mini Sledge Hammer | Rubber Mallet | 22mm Socket
21mm Socket & Wrench | 1/4" Wrench | 8mm Socket
Torque Wrench | Brake Cleaner | Red Loctite | Grease Gun

1.0 Setup

Park the vehicle on level ground and set the parking brake and chock both rear wheels. Jack up the front end from the chassis until the front tires are off the ground. Place jack stands under the front frame rails and set down. Make sure the vehicle is supported correctly and the front tires are still off the ground. Place the jack under the driver side lower arm and raise the tire 1/2", then remove the wheel while keeping jack under lower a-arm to support the suspension. Read these instructions start to finish before moving forward and review diagrams.

2.0 Removal

Using a 21mm socket, loosen the nut from on the upper ball-joint where it connects to the spindle but do not fully remove. With a mini sledge hammer strike the top of the spindle numerous times to release the ball-joint tapered stud. This can be a little difficult since it's a press fit, heating up the spindle to get it to expand will help if need be. Once the ball joint releases from the spindle, then remove the nut. This will allow you to position the upper arm and spindle out of the way. Make sure to position & support the spindle so that it doesn't pull on the brake line and on 4wd models that it doesn't pull out the inner CV or strain the CV boots and axles. You will need to remove the coilover/strut to access the upper arm bolts at the frame. Refer to your coilover instructions or service manual for details. Once the coilover is removed, use a 21mm socket & wrench to loosen and remove the OEM upper arm bolts. Remove the stock upper arm.

3.0 Pre-installation

Using an 8mm socket, install the straight grease zerk fitting into the top of the X-Joint. Do not over tighten or cross thread. Using a 1/4" wrench install the self-tapping zerk fittings into the Camburg arms. Do not bottom out the fittings into the arms. The zerk fitting is two parts that thread together, you may need to remove the nipple when installing. Position them pointing outward for grease gun access.

Now press the polyurethane bushings into the arms. Using the supplied bushing grease, apply grease onto the OD of the inner pivot sleeves and press into the bushings. Wipe excess grease onto outer bushing face and apply additional grease if needed. See diagram for reference.

4.0 Installation

Install the driver side Camburg upper arm into the frame using the original hardware in the same orientation as it was removed. To insure you're installing the correct arm, the zerk fittings and pivot gussets will be on top and the longer a-arm tube towards the front of the vehicle. Our arms are built with higher precision and tighter tolerances than the factory arms, so it will be a tighter fit into the frame. You may need to pry the outer tabs out very slightly to make it easier to install. When the stock arms are tightened from the factory it bends the tabs slightly in. With the bolts pushed all the way through, clean the threads with brake cleaner and apply a little red loctite to the nut area. Use a 21mm wrench and 21mm socket torque to 110 ft/lbs. Re-install coilover/strut.

Cycle the arm up and down to make sure there are no clearance issues. Prior to installing the X-Joint stud into the spindle, make sure the spindle taper is clean and free of debris. Swing down the upper arm so the X-Joint stud inserts into the spindle. Install the M14 washer and castle nut using a 22mm socket and torque to 85 ft/lbs. Do not over-tighten or use an impact gun. Install the new cotter pin through the castle nut. You may need to slightly tighten to align the castle nut slot to the hole in the X-joint stud. Bend cotter pin ends to secure and trim if necessary. See diagram for reference.

IMPORTANT: Now you'll need to grease the X-Joint, if not damage will occur. Using a hand grease gun with a high temp. lithium complex #2 synthetic grease, slowly pump grease into the joint through the zerk fitting making sure not to over grease or over pressurize. When you see the boot to begin to swell, that's a sign the X-Joint is fully greased.

Lastly install the X-Joint XL cap by first installing the supplied o-ring into the caps groove. Then apply a small amount of grease to the inside of the top of the upper arm cup. Use the supplied 30# fishing line and insert 2" of it into the upper arm cup. This will be used to release the trapped air as the cap is pressed on. Position and center the cap over the cup with the Camburg logo in your desired position. Cover the cap with a rag to protect the finish and use a rubber mallet to tap the cover in if not by hand. Make sure to apply even pressure so that it presses in straight. When the cap is fully seated and you hear the air escape, pull the fishing line out and make sure the cap is tight to the cup. Twist the cap a few degrees to the right and left to help seat the cap and o-ring. Periodically check the caps to make sure they are fully seated after off-road use and remove temporarily after any pressure washing for moisture to dissipate.

Repeat steps 1 through 4 to install passenger side arm

5.0 Alignment

You will need to have your vehicle aligned by a qualified shop. Additional caster is built into the Camburg arms to correct alignment issues that are inherent with lifting the vehicle. Have your alignment shop increase positive caster, then set camber and toe to factory OEM specifications. Having an increase in caster helps with straight line stability and cornering precision for performance driving on and off-road.

6.0 Maintenance & Care

Over time the pivot bushings will also need to be cleaned and lubricated. Use grease that's designed specifically for polyurethane bushings. Not using the correct grease can cause the bushings to squeak abnormally and wear faster. The best method to grease the bushings is to remove the arms from the vehicle, disassemble, clean and lubricate. When using a grease gun, do so slowly. Most grease guns operate at 1500+ psi. and can damage the bushings applying too much pressure.

Neglecting care and upkeep will wear parts out faster.

We recommend greasing the polyurethane bushings 2-3 times a year or every 5-8k miles depending on use with a high temp., waterproof teflon (PTFE) based grease like Super Lube.

We recommend greasing the X-Joints 2-3 times per year or every 5-8k miles depending on use with a high temp. lithium complex #2 synthetic grease.

Higher frequency lubing may be required when used off-road and/or in wet/snow/mud conditions.

Inspect and re-torque all hardware and components after the first 500 miles, inspect at your scheduled maintenance intervals and whenever using the vehicle off-road.

Notes

Recommended tire size: 33 in.

Recommended wheel size: 17-20 in.

Recommended wheel backspacing = 4.75-5.00 in.

Maximum wheel backspacing = 5.75 in. (with narrower tires)

Torque OEM nuts to 110 ft/lbs. w/ red loctite

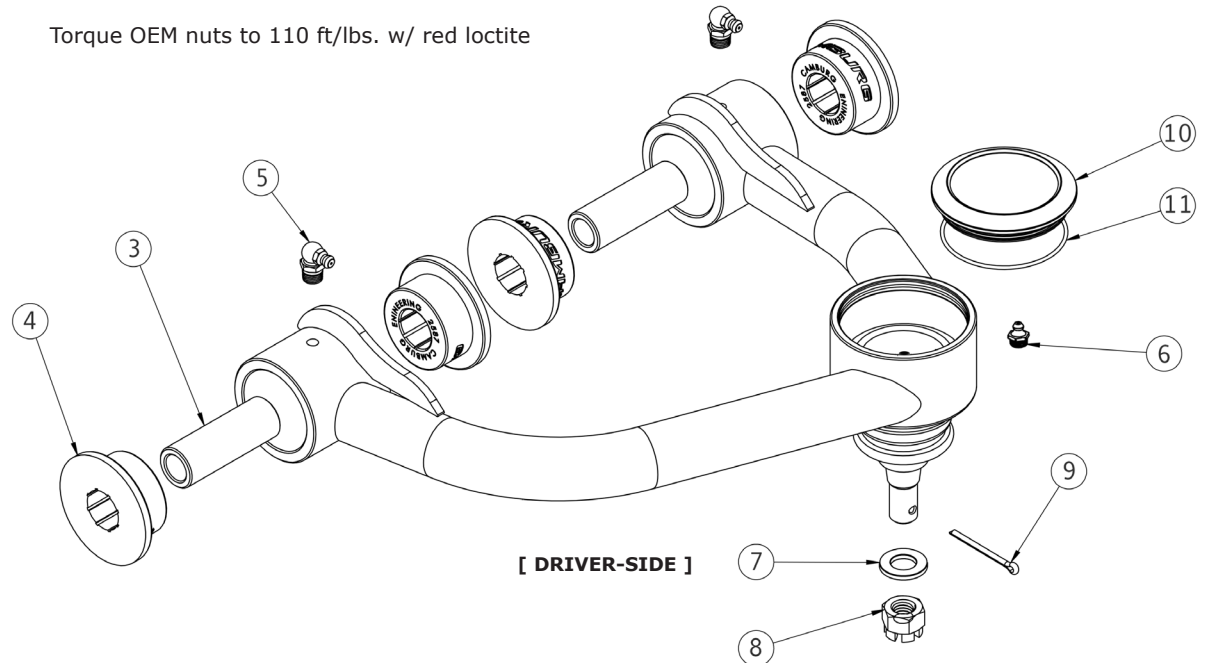

[DRIVER-SIDE]

Torque M14 castle nut to 85 ft/lbs.

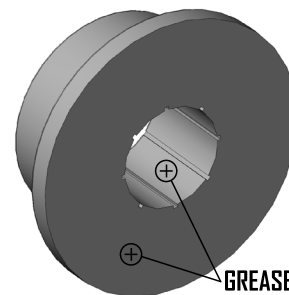

GREASE