

Guardian Comfort Full Bed Liner

TOYOTA TACOMA DOUBLE CAB 60.3" BED BED LINER INSTALLATION INSTRUCTIONS

WARNING: IMPROPER INSTALLATION WILL RESULT IN LINER FLYING OUT OF THE TRUCK! FOLLOW INSTRUCTIONS EXACTLY!

APPROXIMATE INITIAL INSTALLATION TIME LESS THAN 1 HOUR

1. Read all instructions before installing.
2. The bed liner floor and side walls are shipped unzipped.
3. Remove bed liner floor and side walls from box.
4. Zip bed liner floor and side walls together to form the one-piece soft bed liner.
5. A very aggressive hook and loop fastening system has been designed to hold the bedliner in open bed trucks.
6. A continuous loop fastener is sewn around the liner. The bulkhead has three continuous strips of loop fastener sewn along the top and bottom. The tailgate has one continuous strip of loop fastener along the bottom. The hook fasteners have a self-adhesive backing to stick to the truck bed.

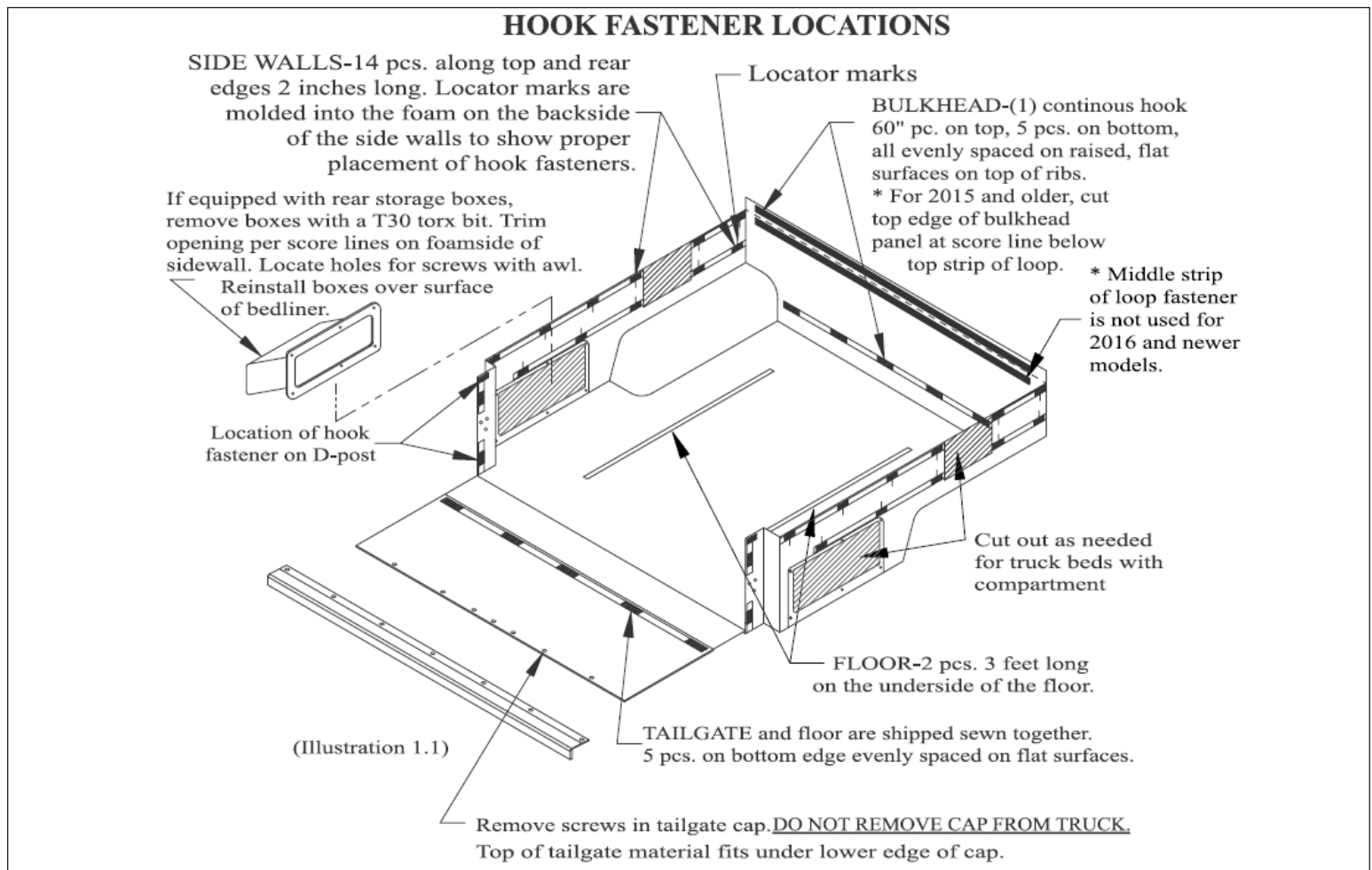

Guardian Comfort Full Bed Liner

Refer to (Illustration 1.1) for completing steps 7-15

7. Remove rear storage compartments from truck bed before installation of bed liner. Remove screws in tailgate cap. **DO NOT REMOVE CAP.**

8. Lay the bed liner in the bed of the truck to determine the exact location and fit. Slide tailgate material under tailgate cap.

IMPORTANT: Never cut or put slits through any seams or sewn areas of the bed liner. This will cause the seam to come completely apart.

9. Roll one side of the bed liner up exposing the floor area where the 3' strip of hook fastener is to be adhered.

10. Using a clean lint-free cloth, clean this area thoroughly using NON-PETROLEUM based solvent. Then with a separate cloth, clean the same area again with alcohol. If the cloths become visually soiled, replace them with clean ones.

11. Attach hook fastener to the loop. Remove the protective liner exposing the adhesive.

NOTE: TRUCK BED SURFACE TEMPERATURE SHOULD BE 68° F OR HIGHER IN ORDER FOR THE HOOK FASTENER TO ACHIEVE MAXIMUM ADHESION. ALSO, NEVER CONTAMINATE THE ADHESIVE BY TOUCHING IT WITH YOUR FINGERS.

Lay the bed liner down, then **FIRMLY** rub the fastener(s) down **VERY AGGRESSIVELY** to assure full engagement of the fastener(s) and the adhesive.

NOTE: For side walls, be sure to place the 2" long hook fasteners at the locator marks which are molded into the foam.

12. Repeat steps 9, 10 and 11 for the opposite side of the bed liner.

13. For 2015 and older, first cut top edge of bulkhead panel at score line below top strip of loop, then repeat steps 10 and 11.

14. Repeat steps 10 and 11 on the siderugs.

15. Repeat steps 10 and 11 for installation of hook fasteners on the tailgate. After the tailgate is placed under factory tailgate cap, install screws with spacers provided in the installation kit. Refer to (Illustration 1.2).

16. Reinstall storage compartments.

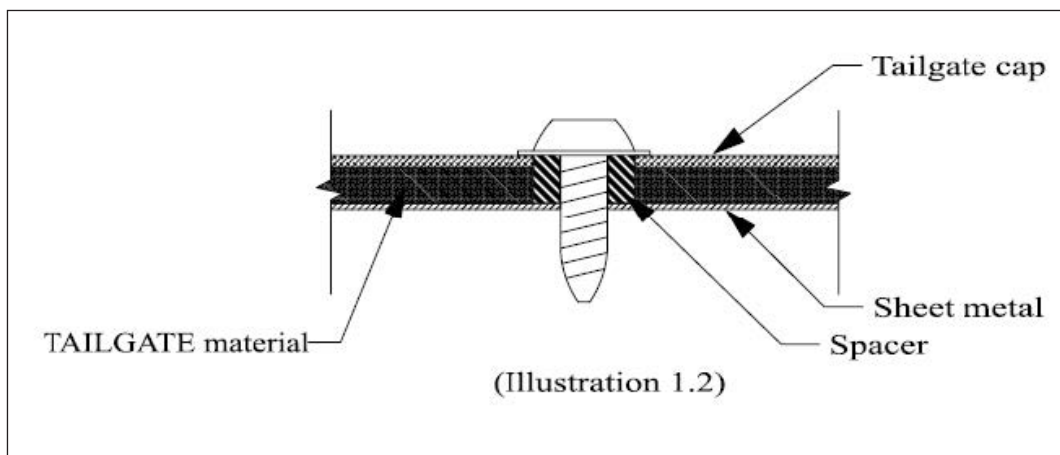

Guardian Comfort Full Bed Liner

CLEANING INFORMATION

The mildew resistant Bed Mat foam will not absorb liquids. The engineered polypropylene fiber top surface resists stains and deterioration from most acids, chemicals, gas and oils, etc. Therefore, by following the cleaning instructions below, your Bed Mat will remain serviceable for as long as you own your truck.

Cleaning your Bed Mat is easy:

1. A vacuum, broom, brush or compressed air can be used to remove dirt, grime, sand, mulch, etc. Due to the fact that water will not harm the Bed Mat, pressure washing is also an effective way to clean a soiled Bed Mat.
2. Although most acids will not harm the Bed Mat, baking soda should be applied immediately to neutralize the acid to ensure the safety of the paint on the truck.
3. To clean tougher jobs such as gasoline, oil, chemicals, acid spills or leaks from your Bed Mat use detergent soap with degreaser and water, then rinse thoroughly. This detergent soap is used in most car wash locations with pressure washing equipment. The Bed Mat polypropylene closed-cell foam will not absorb water and the polypropylene fiber dries in minutes.

Retain this cleaning information with your vehicle owner's manual for future reference.

Congratulations!

We take the utmost pride in our products and want you to enjoy years of satisfaction from your investment. We have made every effort to ensure that your product is top quality in terms of fit, durability, finish and ease of installation.

www.huskyliners.com

Phone: 800-344-8759

Email: customerservice@huskyliners.com



GUARANTEED...FOR LIFE.