



# INSTALLATION INSTRUCTIONS

Not legal for sale or use in California on any pollution controlled motor vehicle.

## 50-2630 FORD 2024-25 RANGER V6-2.7L ECOBOOST

### TOOLS NEEDED:

- Pliers
- Ratchet
- Extension
- 7mm socket
- 8mm socket
- 10mm socket
- Flat head screwdriver
- Panel popper
- T30 torx

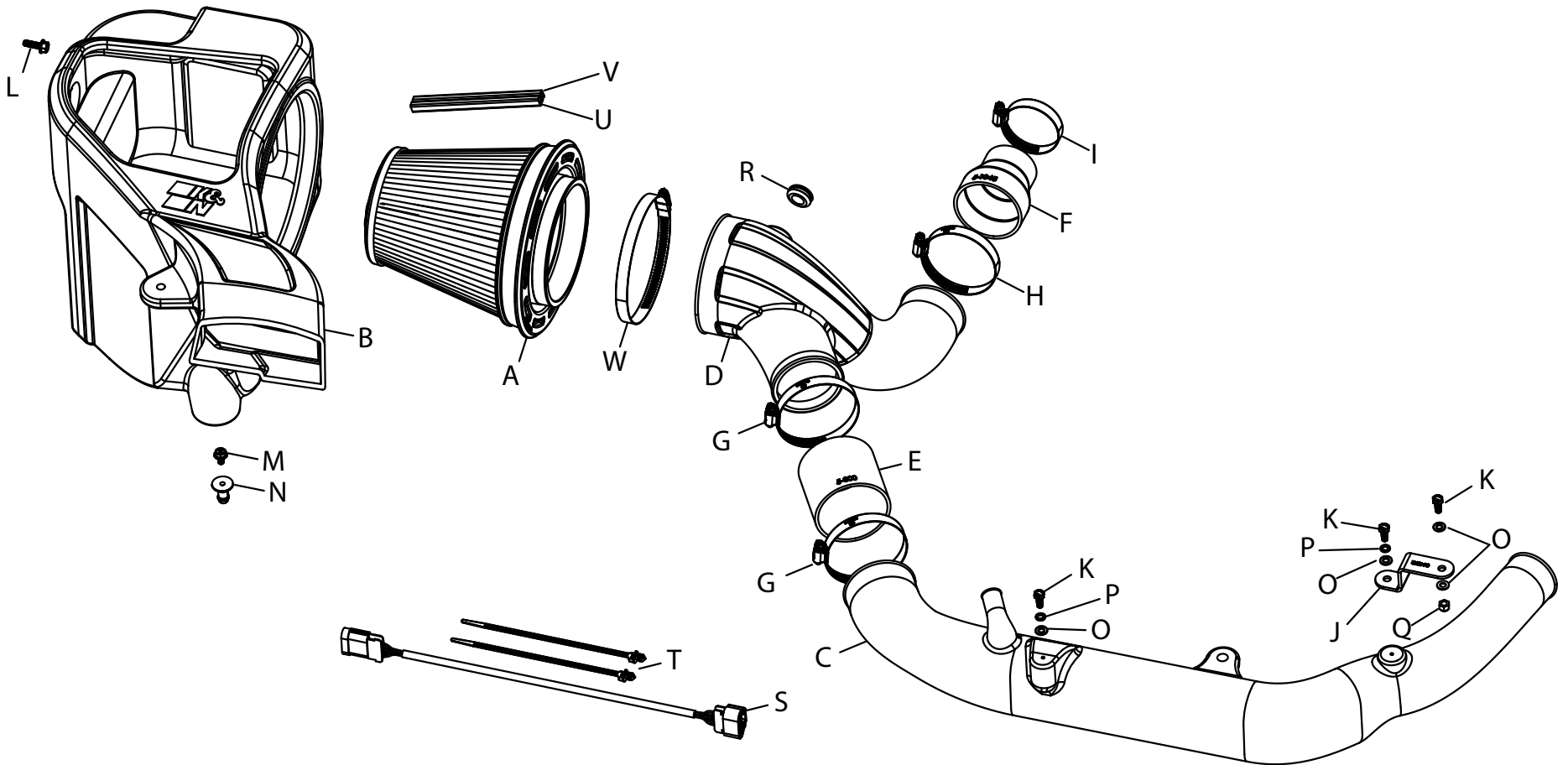

### PARTS LIST:

Description	Qty.	Part #	Description	Qty.	Part #	Description	Qty.	Part #
A AIR FILTER	1	RU-5303	I HOSE CLAMP; #36 BLK	1	087530KA	Q NUT; 6MM NYLOCK	1	07512
B AIR BOX	1	087640	J BRACKET; "Z"	1	064372	R GROMMET; 9/16"ID	1	KITGRMT02
C TUBE; DRIVER SIDE	1	087528	K BOLT; M6-1 X 16MM	3	07812	S EXTENSION HARNESS	1	21783
D TUBE	1	087659	L BOLT; M6-1 X 20	1	1-2038	T ZIP TIE; 8" TREE PUSH-MNT	2	1-127
E HOSE; 3"ID X3"L	1	5-300	M BOLT; M6-1 X 12	1	1-2110	U CLIP; SNAP-ON, RED	1	088222
F HOSE; 2.75" TO 2"ID X 3"L	1	5-1045	N MOUNT; PLASTIC NYLON	1	8-186-1	V CLIP; SNAP-ON, ORANGE	1	088223
G HOSE CLAMP; #48 BLK	2	08601KA	O WASHER; 6MM FLAT	4	08269	W HOSE CLAMP; #88 BLK	1	KITHS88K
H HOSE CLAMP; #44 BLK	1	08577KA	P WASHER; M6 SPLIT LOCK	2	1-3025			

If you need any assistance please call 1-800-858-3333 to speak with a representative in our Customer Service Center before returning the product.

**NOTE: FAILURE TO FOLLOW INSTALLATION INSTRUCTIONS AND NOT USING THE PROVIDED HARDWARE MAY DAMAGE THE INTAKE TUBE, THROTTLE BODY AND ENGINE.**

### TO START:

1. Turn off the ignition and disconnect the negative battery cable.

**NOTE: Disconnecting the negative battery cable erases pre-programmed electronic memories. Write down all memory settings before disconnecting the negative battery cable. Some radios will require an anti-theft code to be entered after the battery is reconnected. The anti-theft code is typically supplied with your owner's manual. In the event your vehicles anti-theft code cannot be recovered, contact an authorized dealership to obtain your vehicles anti-theft code.**



2. Disconnect the coolant hoses from the hot-side charge tube.



3. Release the BOV hose quick connect fitting and disconnect the BOV hose from the intake tube. Then disconnect BOV electrical connection and unhook the wiring harness from the mounting post.



4. Remove the three mounting bolts securing the factory charge tube to the engine. Loosen the hose clamp that secures the right side of the charge tube and then release the two spring clamps and remove the factory charge tube from the vehicle.



5. Loosen the hose clamps that secure the driver's side intake tube.



6. Remove the bolt shown that secures the drivers side intake tube to the cold-side charge tube and then remove the drivers side intake tube from the vehicle.



7. Loosen and remove the T30 torx bolt holding in the front of the air filter housing. Save for later install. Remove the air filter housing mounting bolt on side of vehicle frame.



8. Disconnect intake air temperature sensor. Unhook the wiring harness and coolant hoses from the air filter housing. Remove air scoop.



9. Loosen the hose clamp that secures the passenger side intake hose to the air filter housing.



10. Remove the factory air filter housing from the vehicle. **NOTE: K&N® Engineering, Inc., recommends that customers do not discard factory air intake.**



11. Loosen and remove the air box bracket from vehicle.



12. Remove the bolt on the bottom side of the passenger side intake tube that secures the tube to the engine.



13. Release the spring clamp that secures the intake tube to the turbo and remove the passenger side intake tube. **NOTE: The spring clamp is difficult to release with the tabs positioned towards the bottom of the turbo inlet.**



14. Install the provided step coupler onto the passenger side turbo inlet and secure with the provided hose clamp.



15. Install the provided plastic mount to the bottom of the K&N® air filter housing and secure.



16. Now install the K&N® air filter housing into the vehicle and secure using provided hardware and bolt from step 7.



17. Attach the filter clips to the pleats on the air filter align and push down. Passenger side filters, place orange clip on top and red on bottom.



18. Install the K&N® air filter into the air filter housing.



19. Remove the IAT sensor from the factory intake tube, remove the O-ring from the sensor and then install it into the K&N® intake tube using the provided grommet. Install the provided tree push zip tie to the insert on the intake tube. **NOTE: The IAT sensor is very fragile, use care while handling the sensor so as not to damage it.**



20. Install the K&N® intake tube into filter and the turbo inlet and secure with the provided hose clamps.



21. Install the remaining straight coupler onto the K&N® intake tube and secure with the provided hose clamp.



22. With provided extension harness, connect the original line to the harness and harness to the temperature sensor.



23. Install the driver side K&N® intake tube into the factory turbo inlet coupler and then into the coupler on the passenger side K&N® intake tube, adjust the tube for best fit and secure with the hose clamps and bolt.



24. Release the spring clamp that secures the quick connect fitting onto the BOV hose and then remove the fitting from the hose.



25. Reinstall the factory hot-side charge tube and secure the three connections. Reinstall the factory mounting bolt that secures the tube to the core support.



26. Install the provided "Z" bracket to the hot-side charge tube and K&N® driver side intake tube and secure with the provided hardware.



27. Install the BOV hose onto the fitting on the K&N® intake tube and secure with the provided spring clamp.



28. Reconnect the BOV electrical connections and secure the BOV harness to the stud from step 3.



28. Reconnect the vehicle's negative battery cable. Double check to make sure everything is tight and properly positioned before starting the vehicle.

30. It will be necessary for all K&N® high flow intake systems to be checked periodically for realignment, clearance and tightening of all connections. Failure to follow the above instructions or proper maintenance may void warranty.

#### ROAD TESTING:

1. Start the engine with the transmission in neutral or park, and the parking brake engaged. Listen for air leaks or odd noises. For air leaks secure hoses and connections. For odd noises, find cause and repair before proceeding. This kit will function identically to the factory system except for being louder and much more responsive.

2. Test drive the vehicle. Listen for odd noises or rattles and fix as necessary.

3. If road test is fine, you can now enjoy the added power and performance from your kit.

4. K&N® Engineering, Inc., requires cleaning the intake system's air filter element every 100,000 miles. When used in dusty or off-road environments, our filters will require cleaning more often. We recommend that you visually inspect your filter once every 25,000 miles to determine if the screen is still visible. When the screen is no longer visible some place on the filter element, it is time to clean it. To clean and re-oil, purchase our filter Recharger® service kit, part number 99-5050 or 99-5000 and follow the easy instructions.