



IMPORTANT! READ THIS FIRST!

Installation of shock absorbers or other suspension components requires special tools and expert knowledge. Accordingly, installation of all BILSTEIN products must be performed by a professional automotive suspension technician.

When replacing other brands, BILSTEIN shock absorbers or other suspension components should always be installed as a set. All BILSTEIN products must only be used for the specific, intended application as indicated in the application guide.

Any use of any BILSTEIN product other than for its intended use may result in serious bodily injury or death.

Always use a chassis hoist for the installation of BILSTEIN products and make certain that the raised vehicle is securely attached to the hoist and/or supported to prevent the vehicle from slipping, falling, or moving during the installation process.

If you install any BILSTEIN product without the necessary special tools, expertise, and chassis hoist, you may subject yourself to the risk of serious bodily injury or death.

BILSTEIN shock absorbers are gas-filled and are highly pressurized.

- Never place any BILSTEIN shock absorbers in a vise or use a clamp on any BILSTEIN shock absorber.
- Never apply heat near any BILSTEIN shock absorber.
- Never attempt to open or repair any BILSTEIN product, in order to prevent **serious bodily injury or death**.

Any attempt to misuse, misapply, modify, or tamper with any BILSTEIN suspension product voids any warranty and **may result in serious bodily injury or death**.

While installing any BILSTEIN product:

- Do not use impact tools for loosening or tightening fasteners, because this may destroy the screw threads.
- Self-locking fasteners must only be used **once!**
- Reuse original equipment components only if they are in good condition, otherwise replace them with new components.
- Never remove the slight film of oil on the shock absorber piston rod and seal.
- All mounting fasteners for shock absorbers and other suspension components must be securely tightened before tension is placed on the suspension system, unless otherwise specified in the manufacturer's service manual or in this instruction.

After installing any BILSTEIN product:

- The suspension caster and camber must be checked and/or adjusted to comply with the vehicle manufacturer's specifications.
- The (load dependent) brake compensator and the anti-lock brake system must be checked and/or reset to comply with the vehicle manufacturer's specifications.
- The headlight aim must be checked and adjusted. Or, if applicable, adaptive headlights must be checked and recalibrated to comply with the vehicle manufacturer's specifications.
- If applicable, any/all Advanced Driver Assistance Systems (ADAS) must be checked and recalibrated to comply with the vehicle manufacturer's specifications.

CAUTION for COILOVER TYPE SUSPENSIONS!!!

If disassembling a coilover type suspension, refer to the vehicle manufacturer's service manual for proper procedures. The coil spring is preloaded and must be compressed with a spring compressor to release load before the upper mount is disassembled. Failure to follow the vehicle manufacturer's procedures may cause serious injury or death, and may damage the vehicle.

IMPORTANT!!!

This BILSTEIN product may or may not be compatible with non-BILSTEIN aftermarket products and/or vehicle modifications. It is the responsibility of the professional automotive suspension technician performing the installation to identify any non-OEM components and/or modifications on the vehicle that may interact with the suspension system. These must be evaluated for any potential physical static or dynamic interference with and/or effect on the function of this BILSTEIN product.

E-WM05-0000100AA MOUNTING INSTRUCTION



This instruction is for both left front (driver) 41-326084 and right front (passenger) 41-326091 B8 8112 shocks. A bill of materials of the included mounting part kits is shown below and on the next page.

Note: These shocks must be installed with aftermarket upper control arms. The OEM upper control arms will contact the reservoir hose, potentially causing damage. For guaranteed fitment use Bilstein upper control arms, part # 51-353032 or 51-304706.

It is normal to hear a slight audible clicking noise during compression and rebound strokes in the B8 8112 shocks, most notably during low velocity events. This is due to the internal pistons engaging each other creating the position sensitive compression and rebound zones.

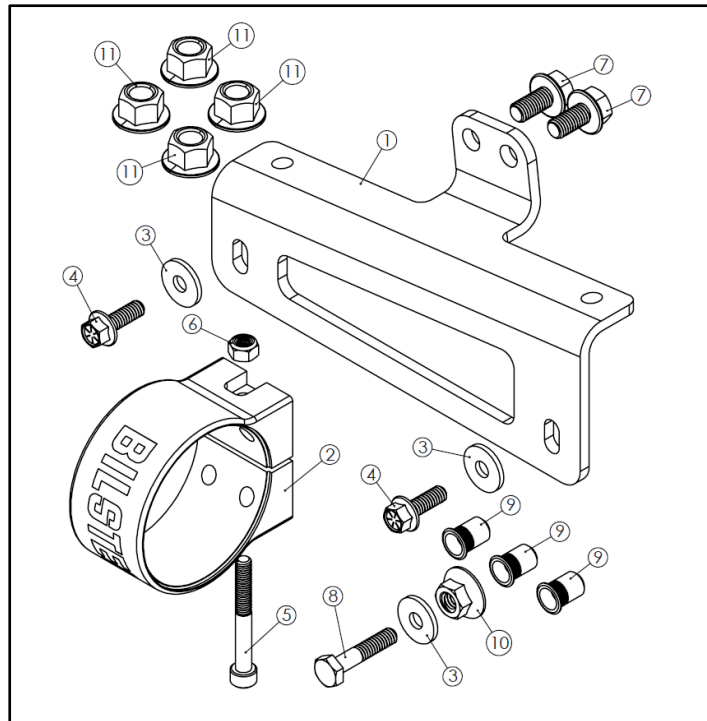

Bill of Materials – LEFT FRONT		
Item #	Description	Qty
1	Reservoir Mount Plate; Left	1
2	Reservoir Clamp	1
3	Washer	3
4	Flange Head Cap Screw; ¼”-20; L = ¾”	2
5	Socket Head Cap Screw; M6x1; L = 50mm	1
6	Nylon-Insert Locknut; M6x1	1
7	Flange Head Cap Screw; M8x1.25; L=16mm	2
8	Hex Head Cap Screw; ¼”-20; L = 1.25”	1
9	Rivet Nut; ¼”-20 Thread	3
10	Serrated Hex Flange Nut; 5/16”-18	1
11	Flange Locknut; M10x1.5	4

E-WM05-0000100AA MOUNTING INSTRUCTION

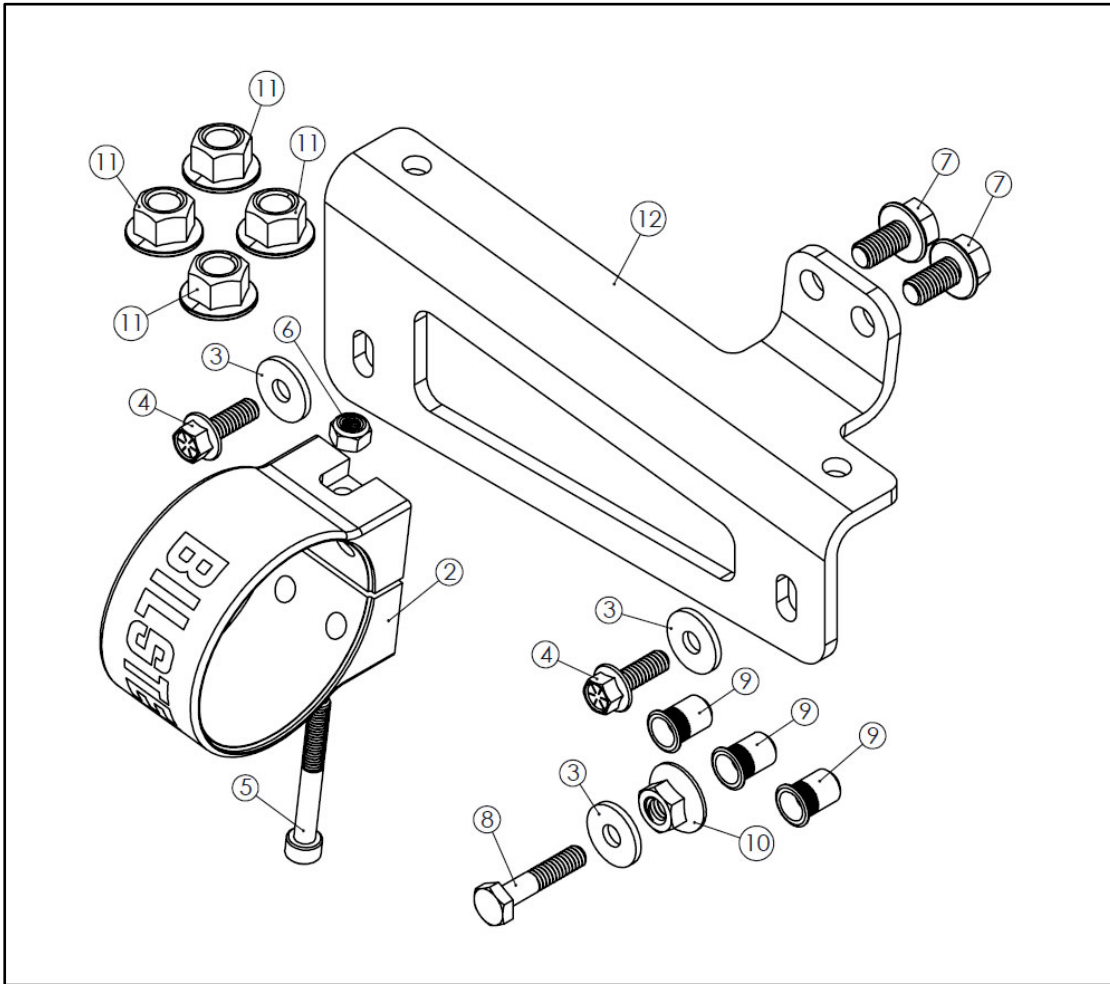

Bill of Materials – RIGHT FRONT		
Item #	Description	Qty
12	Reservoir Mount Plate; Right	1
2	Reservoir Clamp	1
3	Washer	3
4	Flange Head Cap Screw; 1/4"-20; L = 3/4"	2
5	Socket Head Cap Screw; M6x1; L = 50mm	1
6	Nylon-Insert Locknut; M6x1	1
7	Flange Head Cap Screw; M8x1.25; L=16mm	2
8	Hex Head Cap Screw; 1/4"-20; L = 1.25"	1
9	Rivet Nut; 1/4"-20 Thread	3
10	Serrated Hex Flange Nut; 5/16"-18	1
11	Flange Locknut; M10x1.5	4

B8 8112 Shock Installation Procedure:

- A. Remove existing shock module from the vehicle following all procedures in the vehicle manufacturer's service manual. Save the lower shock bolt and nut as they will be used later.
- B. Before installing the B8 8112 shocks on the vehicle, check if they are set at the desired lift height. The pre-set lift height for 4WD is approximately 2.75" with adjustment up to 3.25" and down to 2.25". For 2WD the pre-set lift height is approximately 3.25" with adjustment down to 2.75". For 2WD, do not set any higher than the pre-set lift height as this will not allow enough down travel before rebound zone engagement.
- C. If the above-mentioned pre-set lift height is not what is desired, proceed to Step D. Otherwise, skip to Step J.
- D. Break the spring seat lock ring loose with the supplied spanner wrenches. Refer to [Figure 1](#) below.
- E. Note the clocking of the lower mount relative to the studs on the upper mount (important for reassembly). This damper was designed with an offset towards the rear of the vehicle. Ensure the larger heim spacer labeled in [Figure 1](#) is facing towards the front of the vehicle.
- F. Using an appropriate spring compressor, compress the spring until it can be rotated freely by hand. Then, spin the spring seat up or down depending on what the desired lift height is. Note that the right side (passenger) should always be approximately 8mm lower than the left side (driver) to compensate for the inherent vehicle lean. See the lift height table below for a few points of reference between the amount of exposed thread and estimated lift height. They are listed for stock weight vehicles.

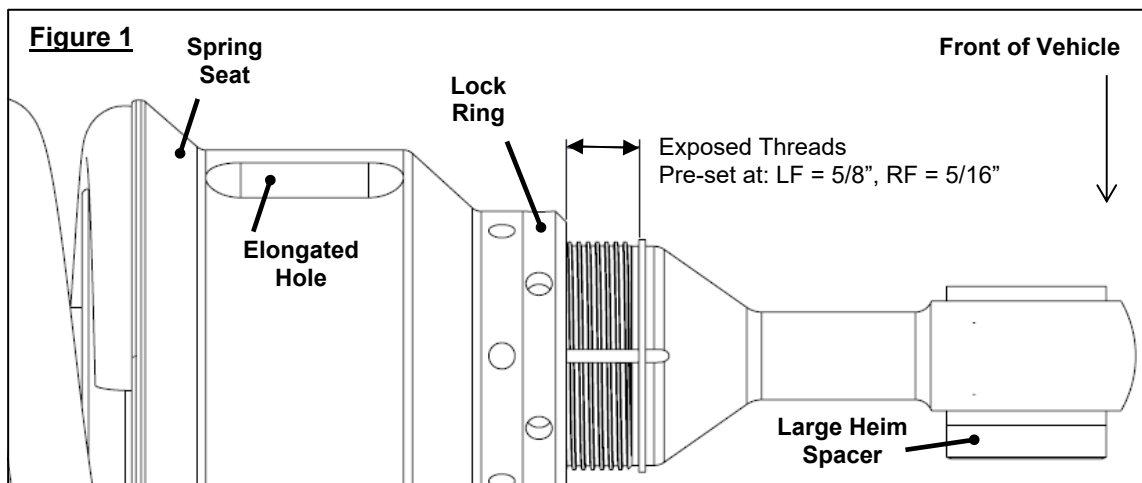

2007-2021 Toyota Tundra			
Exposed Threads		B8 8112 Typical Lift Heights**	
Left Front	Right Front	4WD	2WD
15/16"	5/8"	3.25" lift	DO NOT USE
5/8"	5/16"	2.75" lift	3.25" lift
5/16"	0" (very bottom)	2.25" lift	2.75" lift

E-WM05-0000100AA

MOUNTING INSTRUCTION

BILSTEIN



** Lift heights indicated are typical. Actual lift height is influenced by which factory suspension the vehicle is equipped with and its condition; optional equipment and accessories on your vehicle, and other vehicle modifications such as replacement coil springs, wheel and tire combinations, etc. Modifying/lifting the suspension to your vehicle may raise its center of gravity and may make it more susceptible to loss of control and/or rollover, which may result in death or serious injury. We strongly recommend that you offset the loss of rollover resistance as much as possible by increasing tire track width. Wear seat belts at all times and avoid situations where a side rollover may occur.

Left Front (Driver) Installation Procedure

G. Once the desired lift height is set, tighten the lock ring against the spring seat using supplied spanner wrenches.

Torque lock ring to spring seat 37 ft-lb (50 Nm).

H. Rotate the lower shock mount so it is aligned with the upper mount studs as noted in Step E with the larger heim spacer towards the front of the vehicle.

I. Slowly release the spring compressor.

J. Install the shock onto the vehicle as shown below. Use the four Flange Locknuts (BOM item #11) and a 15mm socket to attach the upper mount. Leave reservoir hanging temporarily towards the front of the vehicle.

Torque Flange Locknuts to 33 ft-lb (45 Nm).

K. Attach the lower shock mount with the OE shock bolt and nut that was removed in Step A. For the lower mount, make sure the large heim spacer is towards the front of the vehicle (see lower mount images below).

Torque lower OE shock bolt and nut to service manual specification.



Driver Side



Passenger Side



Large
Heim
Spacer

E-WM05-0000100AA MOUNTING INSTRUCTION

BILSTEIN



- L. Remove the splash guard clips circled below and set aside (clips will be reused). Tuck back splash guard.

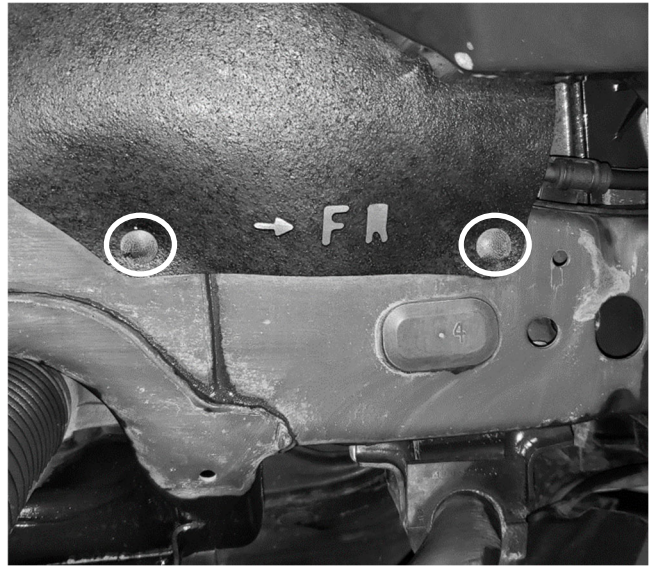
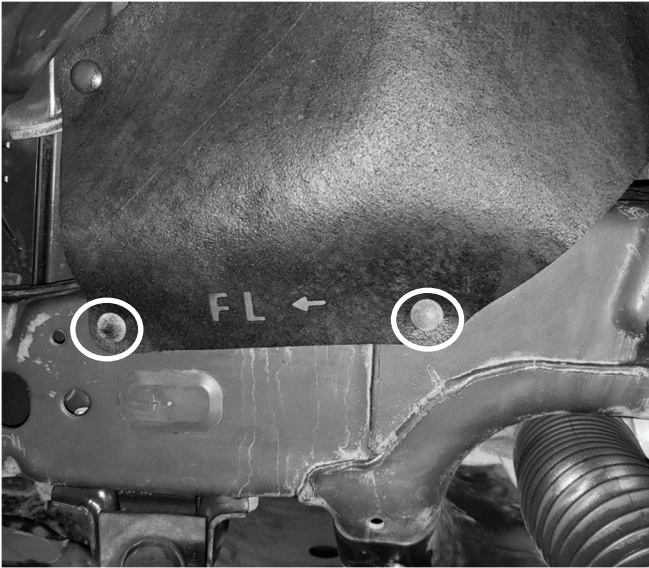

- M. Using a 25/64" drill bit, drill the 2 holes that the clips were removed from.
- N. Install the supplied 1/4"-20 rivet nuts (BOM item #9) into the drilled holes using a rivet gun. If you do not have access to a rivet gun, refer to the Rivet Nut Supplemental Instructions at the end of this document for installation of the rivet nuts.
- O. Using BOM items # 2, 5 and 6, assemble the reservoir clamp bracket as shown below. Ensure the screw and nut are on the correct side with the BILSTEIN lettering oriented as shown below.



Screw



Nut

E-WM05-0000100AA MOUNTING INSTRUCTION

BILSTEIN



- P. Take this assembly and attach it to the Reservoir Mount Plate (BOM item # 1) using the two M8 x 1.25 flange head screws (BOM item # 7) as shown below. Apply a non-permanent thread locker to these screws before assembly. Tighten using a 13mm socket and **torque Flange Head Cap Screws to 18 ft-lb (25 Nm)**. Ensure the Bilstein lettering is oriented as below and the reservoir clamp screw (BOM item # 5) is on the top side of the bracket.

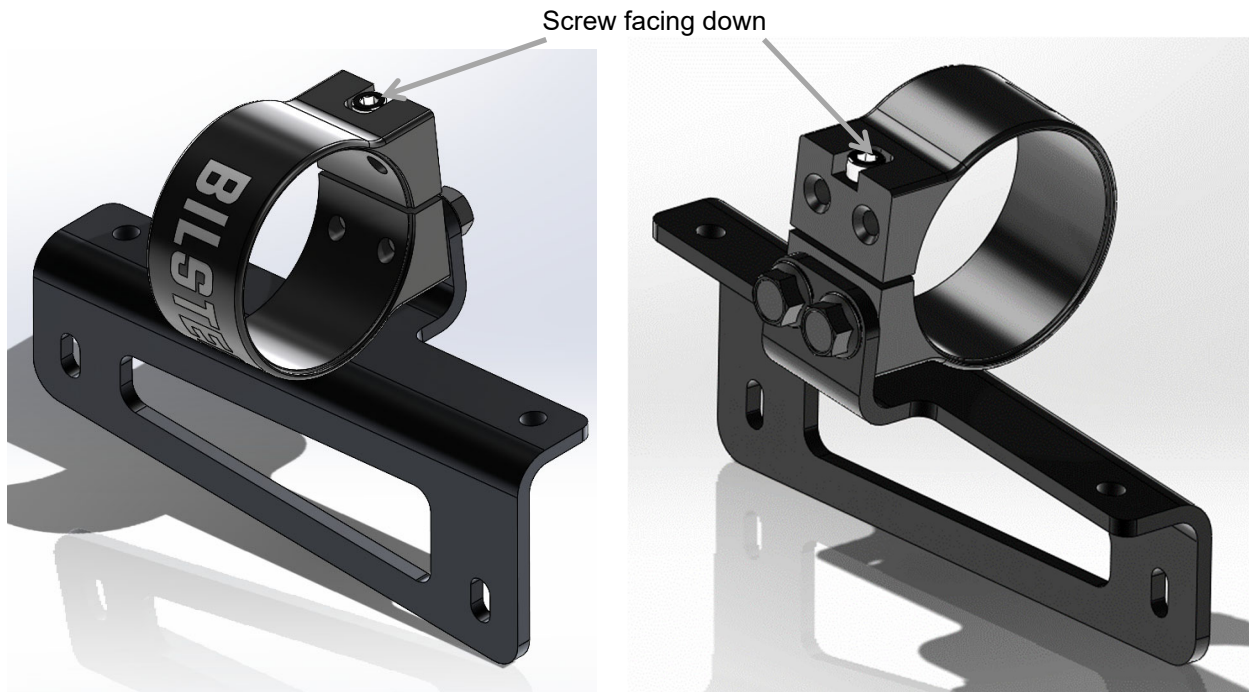

- Q. Using the splash guard clips removed in Step L, install them on the opposite side of the splash guard as shown circled below.



E-WM05-0000100AA MOUNTING INSTRUCTION

BILSTEIN



- R. Insert the Reservoir into the Reservoir Clamp (BOM item # 2) keeping the clamp loose for now.
- S. Install the two clips into the two holes on the bottom of the Reservoir Mount Plate (BOM item # 1) as shown below. It may be easier to remove the splash guard from the vehicle entirely to install on the bracket.



- T. With the reservoir still loose in the Reservoir Clamp, install the entire mount bracket assembly onto the frame as shown below using the rivet nuts with the washers (BOM item # 3) and 1/4"-20 flange head screws (BOM item # 4). Apply non-permanent thread locker to the threads and **torque Flange Head Screws to 16 ft-lb (22 Nm)**.



E-WM05-0000100AA MOUNTING INSTRUCTION

BILSTEIN



- U. Position the reservoir so that the label's edge meets the bracket, and that the Schrader cap on the left end is not contacting anything. Clock the reservoir such that the hose port and fitting is not contacting the reservoir mount plate, see below.

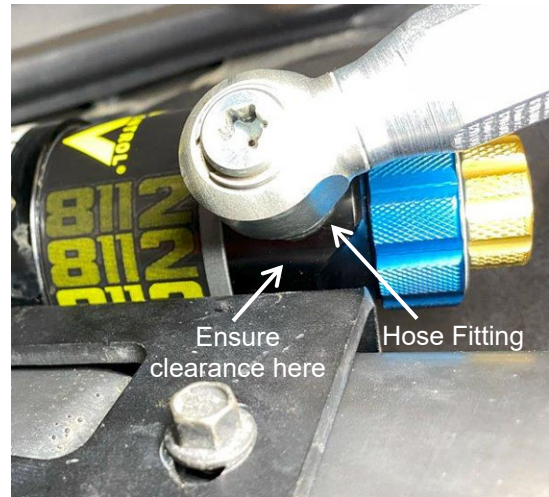

- V. Once the reservoir position is confirmed, tighten the reservoir clamp screw on the top side of the reservoir clamp. **Torque the Socket Head Cap Screw to 6 ft-lb (8 Nm).**

Final left front (driver) 41-326084 B8 8112 shock installed on vehicle:

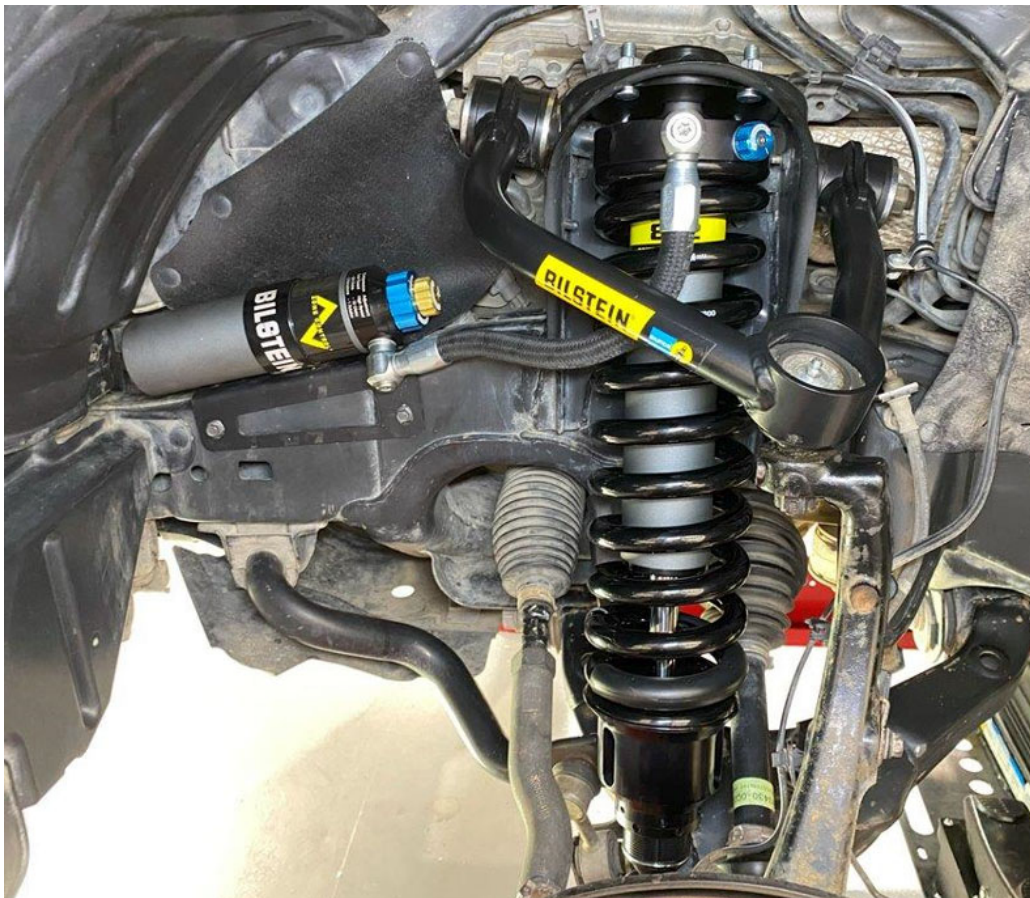

E-WM05-0000100AA MOUNTING INSTRUCTION

BILSTEIN



Right Front (Passenger) Installation Procedure

AA. For the right side, repeat Steps A-N from the vehicle left side installation procedure.

BB. Using BOM items # 2, 5 and 6, assemble the reservoir clamp bracket as shown below. Ensure the screw and nut are on the correct side with the BILSTEIN lettering oriented as shown below.

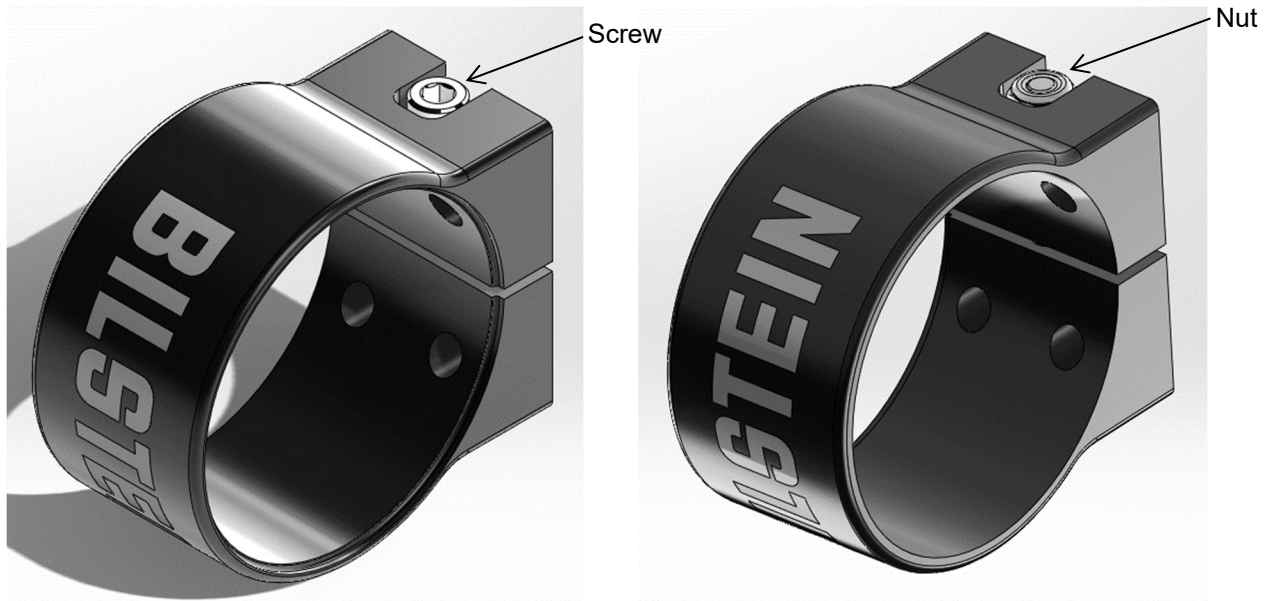

CC. Take this assembly and attach it to the Reservoir Mount Plate (BOM item # 12) using the two M8 x 1.25 flange head screws (BOM item # 7) as shown below. Apply a non-permanent thread locker to these screws before assembly. Tighten using a 13mm socket and **torque Flange Head Cap Screws to 18 ft-lb (25 Nm)**. Ensure the Bilstein lettering is oriented as below and the reservoir clamp screw (BOM item # 5) is on the top side of the bracket.

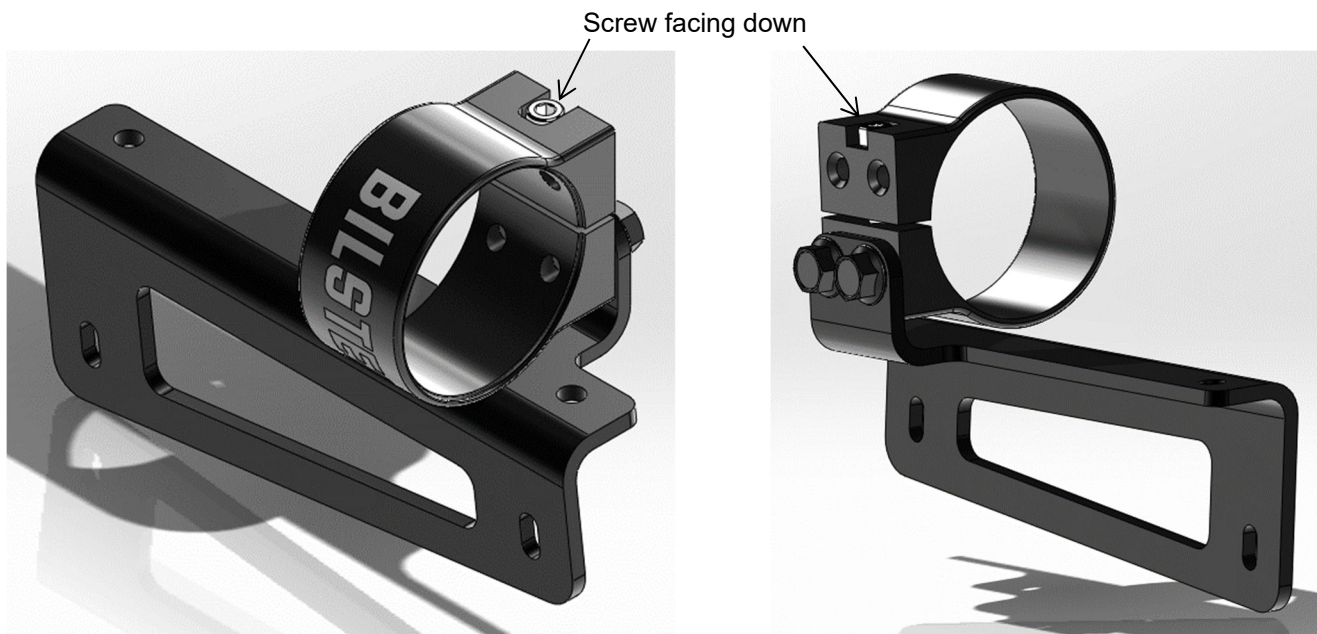

E-WM05-0000100AA MOUNTING INSTRUCTION

BILSTEIN



DD. Insert the Reservoir into the Reservoir Clamp (BOM item # 2) keeping the clamp loose for now.

EE. With the reservoir still loose in the Reservoir Clamp, install the entire mount bracket assembly onto the frame as shown below using the rivet nuts with the washers (BOM item #3) and ¼"-20 flange head screws (BOM item # 4). There is no need to torque the fasteners at this time.



FF. Since it is not possible to clamp the reservoir tight on this side of the vehicle when the reservoir support bracket is installed, the reservoir position must be marked using a black marker and tightened after removal.

GG. Position the reservoir so that the edge of the label meets the edge of the bracket like shown below, check clearances of the Schrader cap and hose fitting the same as in Step U from the left side installation procedure. Once the reservoir is in position, mark the reservoir and reservoir clamp with a black marker as shown circled below.



E-WM05-0000100AA MOUNTING INSTRUCTION

BILSTEIN



HH. If the reservoir and/or the reservoir clamp are contacting the black plastic panel pictured above, it may be necessary to trim it using shears. See below for before and after trimming.



- II. Once the reservoir is marked, remove the entire reservoir bracket assembly from the vehicle. Line up the marks that were made on the reservoir and tighten the reservoir clamp screw.
Torque the Socket Head Cap Screw to 6 ft-lb (8 Nm).
- JJ. Using the splash guard clips removed in Step L of the left side installation procedure, install them on the opposite side of the mud guard as shown circled below.



E-WM05-0000100AA MOUNTING INSTRUCTION

BILSTEIN



KK. Install the two clips into the two holes on the bottom of the Reservoir Mount Plate (BOM item # 12) as shown below. It may be easier to remove the splash guard from the vehicle entirely to install on the bracket (Note: image below is of the left (driver) side).



LL. The reservoir bracket assembly and reservoir can now be re-installed on the frame of the vehicle. Apply non-permanent thread locker to the threads of the 1/4"-20 flange head screws (BOM item # 4), and fasten the bracket with washers (BOM item #3) to the rivet nuts.

Torque Flange Head Screws to 16 ft-lb (22 Nm).



**E-WM05-0000100AA
MOUNTING INSTRUCTION**



Final right front (passenger) 41-326091 B8 8112 shock installed on vehicle:





Dual Speed Reservoir Adjustment

These dampers come equipped with independent high and low speed compression damping adjusters located on the reservoir. The high speed is the blue knob and is labeled as such, and the low speed is the gold knob and is labeled as such. The **FULL FIRM** setting for each adjuster knob is achieved when the knob is turned all the way **CLOCKWISE**. The **FULL SOFT** setting for each adjuster knob is achieved when the knob is turned all the way **COUNTER-CLOCKWISE**. To make high or low speed adjustments, simply turn each knob individually until the desired level of control is achieved. To stiffen the ride, turn the knobs clockwise. To soften the ride, turn the knobs counter-clockwise.

The factory setting of these adjusters are as follows:

- High Speed (blue knob) – 6 clicks counter-clockwise from fully firm.
(10 total settings are available which translates to 9 clicks; 1 rotation)
- Low Speed (gold knob) – 13 clicks counter-clockwise from fully firm.
(20 total settings are available which translates to 19 clicks; 2 rotations)

Please note: It's normal for the high speed (blue) knob to become significantly more difficult to turn when progressing to the firmer end of the adjustment range; particularly during the last 3 to 4 settings/clicks. This increased difficulty is a result of the increasing preload of the high speed valve stack shims. To aid in ease of adjustment at the firmest end of the high speed range, it's optional to use Bilstein wrench part # E-XS01-0000004. This is included in most kits and if not, available separately. Additionally, it's normal for the clicks on the high speed (blue) knob to become less pronounced at the firmer end of the adjustment range.



Dual Speed Reservoir Adjuster



Zone Control JCO (Jounce Cut-off) Adjustment

These dampers also come equipped with an adjuster for the JCO (jounce cut-off) system. This blue adjuster knob is located on the mount cap above the coil spring. The **FULL FIRM** setting for the adjuster knob is achieved when the knob is turned all the way **CLOCKWISE**. The **FULL SOFT** setting for the adjuster knob is achieved when the knob is turned all the way **COUNTER-CLOCKWISE**. To make JCO adjustments, simply turn the adjuster knob clockwise for more bottom out control and counter-clockwise for less bottom out control. The adjustment will not affect the ride quality when the vehicle is in the main damping zone at regular ride height.

The JCO adjuster factory setting is:

- 6 clicks counter-clockwise from fully firm.
(10 total settings are available which translates to 9 clicks; 1 rotation)



JCO (Jounce Cut-off) Adjuster

Rivet Nut Supplemental Instructions

Process for installing Rivet Nuts into frame (complete this procedure for all Threaded Inserts)

- A. If you have access to a Rivet Gun or pliers, this may be preferable to set the provided Rivet Nuts. Otherwise, using the BOM items shown below and a $\frac{1}{2}$ " box end wrench, arrange them as shown and turn the $\frac{1}{4}$ "-20 hex head cap screw by hand until it is snug.

Note that the screw will pass through the serrated flange nut without engaging the threads. The threads will instead engage the Threaded Insert. The serrations on the flange nut prevent the Threaded Insert from rotating while setting it.

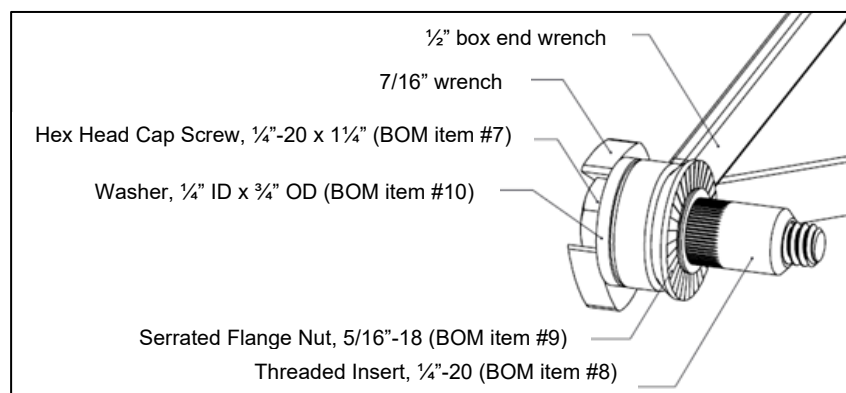
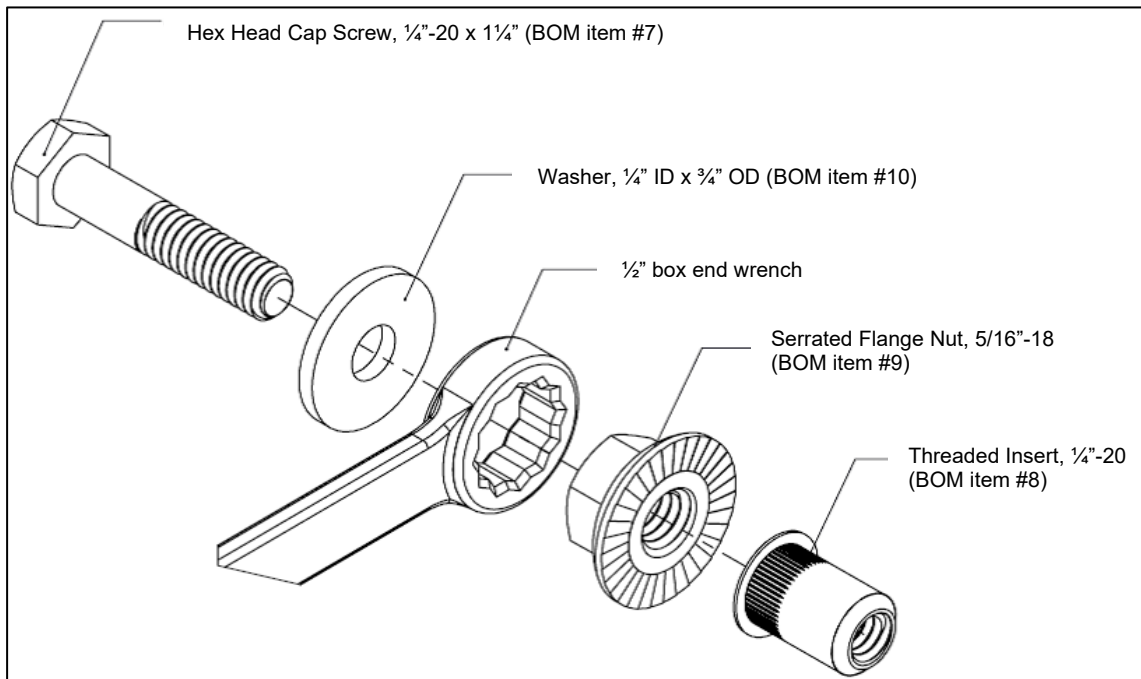

E-WM05-0000100AA MOUNTING INSTRUCTION

BILSTEIN



- B. Place the Threaded Insert into the hole.



- C. While keeping the Threaded Insert flange firm and parallel against the frame rail, tighten the screw using a 7/16" box end wrench or socket. Turn it 2.5 rotations to set the Threaded Insert. Tightening in 1/4 turn increments tends to work well.



- D. Remove the screw, washer, and flange nut. The Threaded Insert should now be rigidly fixed in the hole as shown below.

