

1979 and Subsequent Years Ford Mustang Rear Springs Placement

It is necessary to make that the end of the coil on the rear spring locates as illustrated. Note that the end of the coil is sitting in the center of the trailing arm towards the axle. This placement true of both left and right springs.

Not locating the springs in the manner could mean the difference of 5 - 10 mm at the wheel.

Ford Mustang

All Models & Years

When installing the Pro-Kit, it is necessary to install the new short Pinion Snubber to allow for proper clearance in the rear suspension. This assembly is located directly over the third member in the drive shaft tunnel.

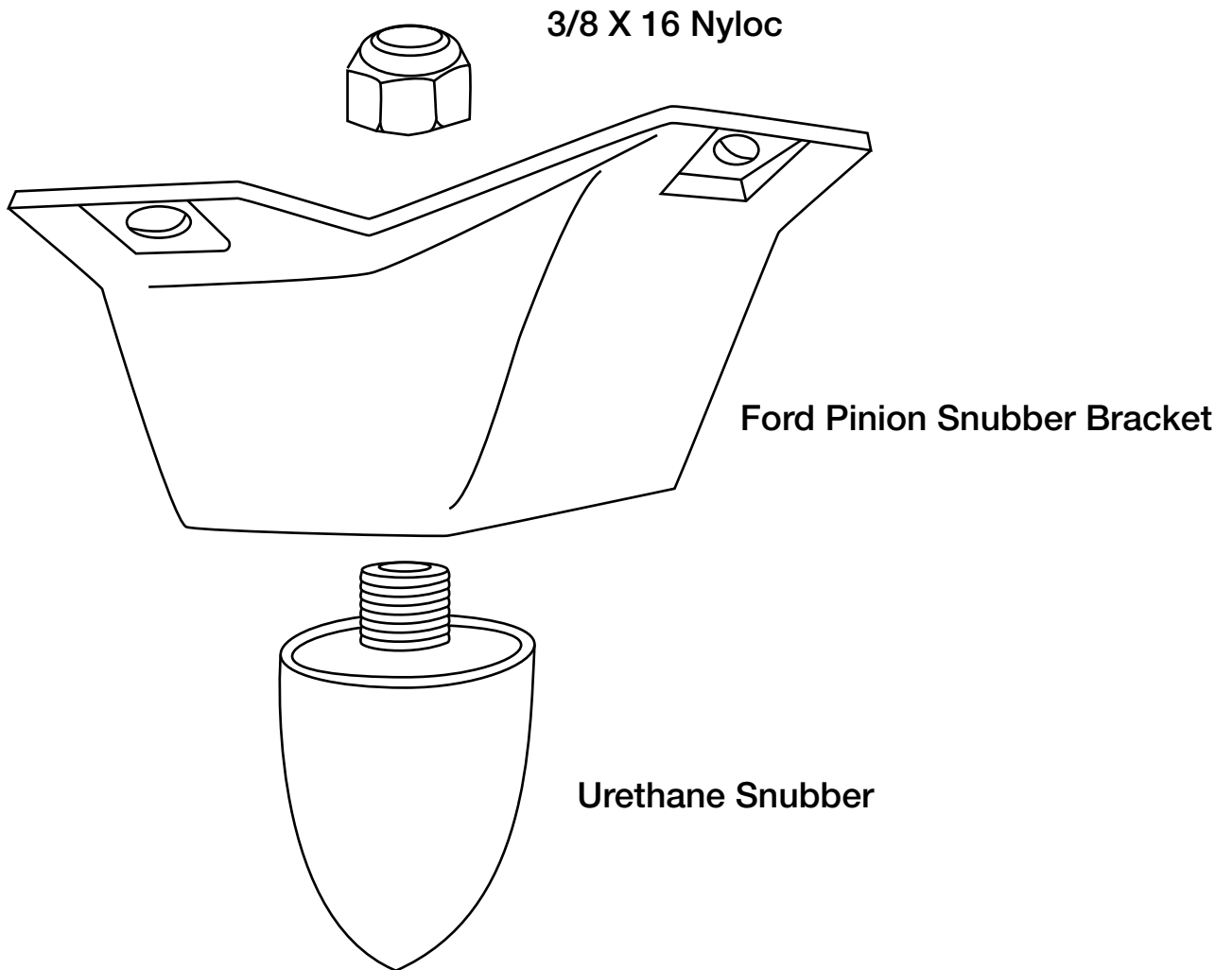

Installation Instructions

1. Remove the three bolts that hold the snubber assembly to the chassis and remove the assembly from the vehicle.
2. Remove the nut holding the rubber bumper to the bracket and remove from the bracket.
3. Install the Urethane bump stop to the bracket and fasten with the 3/8 x 16 Nyloc nut.
4. Install the assembly to the vehicle and reattach using the three bolts you previously removed.