

AIR LIFT
PERFORMANCE

INSTALLATION GUIDE



Nissan 350z (Z33) Infiniti G35

FRONT APPLICATION

*EXCLUDING AWD

Kit 76013

For maximum effectiveness and safety, please read these instructions completely before proceeding with installation.

Failure to read these instructions can result in an incorrect installation which could result in damage to the vehicle, minor to severe personal injury or death.

Protect your Air Lift Performance Purchase by Completing your Warranty Registration

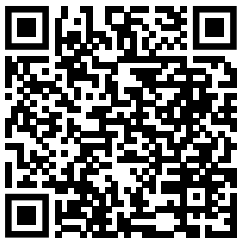

Thank you for purchasing an Air Lift Performance product!

Take a photo of your sales receipt and then scan the QR code to complete your online warranty registration.

TABLE OF CONTENTS

P.02

Introduction

Notation Explanation

P.03

System Overview

P.04

Install the System

Important Safety Notices

Section 1. Prepare the Vehicle

Section 2. Stock Suspension Removal

Section 3. Install the Kit Components

Section 4. Route the Air Lines

P.08

Before Operating

Set the Ride Height

Torque Specifications

Suggested Driving Air Pressure

Maximum Air Pressure

Check for Binding

Installation Checklist

Damping Adjustment

P.10

Limited Warranty and Return Policy

Introduction

Air Lift Performance thanks you for purchasing the most complete, fully engineered high-performance air suspension made for the Nissan 350z (Z33)/Infiniti G35. Read these installation instructions to correctly and safely set up the vehicle for a #lifeonair.

Air Lift assumes that the installer has the mechanical knowledge and ability to work on vehicle suspension systems and has basic tools necessary to complete the project. Special tools needed to complete the installation are noted on the System Overview page.

Air Lift Performance reserves the right to make changes and improvements to its products and publications at any time. For the latest version of this manual, contact Air Lift Performance at **(800) 248-0892** or visit **www.airliftperformance.com**.

An Air Lift air management system is highly recommended for this product. Learn more at **air-lift.co/productlines**.

NOTATION EXPLANATION

Hazard notations appear in various locations in this publication. Information highlighted by one of these notations must be observed to help minimize risk of personal injury or possible improper installation, which may render the vehicle unsafe. Notes are used to help emphasize areas of procedural importance and provide helpful suggestions. The following definitions explain the use of these notations as they appear throughout this guide.



DANGER

INDICATES IMMEDIATE HAZARDS WHICH WILL RESULT IN SEVERE PERSONAL INJURY OR DEATH.



WARNING

INDICATES HAZARDS OR UNSAFE PRACTICES WHICH COULD RESULT IN SEVERE PERSONAL INJURY OR DEATH.



CAUTION

INDICATES HAZARDS OR UNSAFE PRACTICES WHICH COULD RESULT IN DAMAGE TO THE VEHICLE OR MINOR PERSONAL INJURY.



NOTE

Used to help emphasize areas of procedural importance and provide helpful suggestions.



TECH TIP

Used to provide helpful tips to ease the installation process.

System Overview

HARDWARE LIST

Item	Part #	Description	Qty
A	35732	ASM, Strut, 350z, Front	2
B	20997	Leader Line, 1/4" ID	2
C	21810	UN, 1/4" FNPT X 1/4" PTC, DOT	2
D	21987	UN, 1/4" FNPT X 3/8" PTC, DOT	2

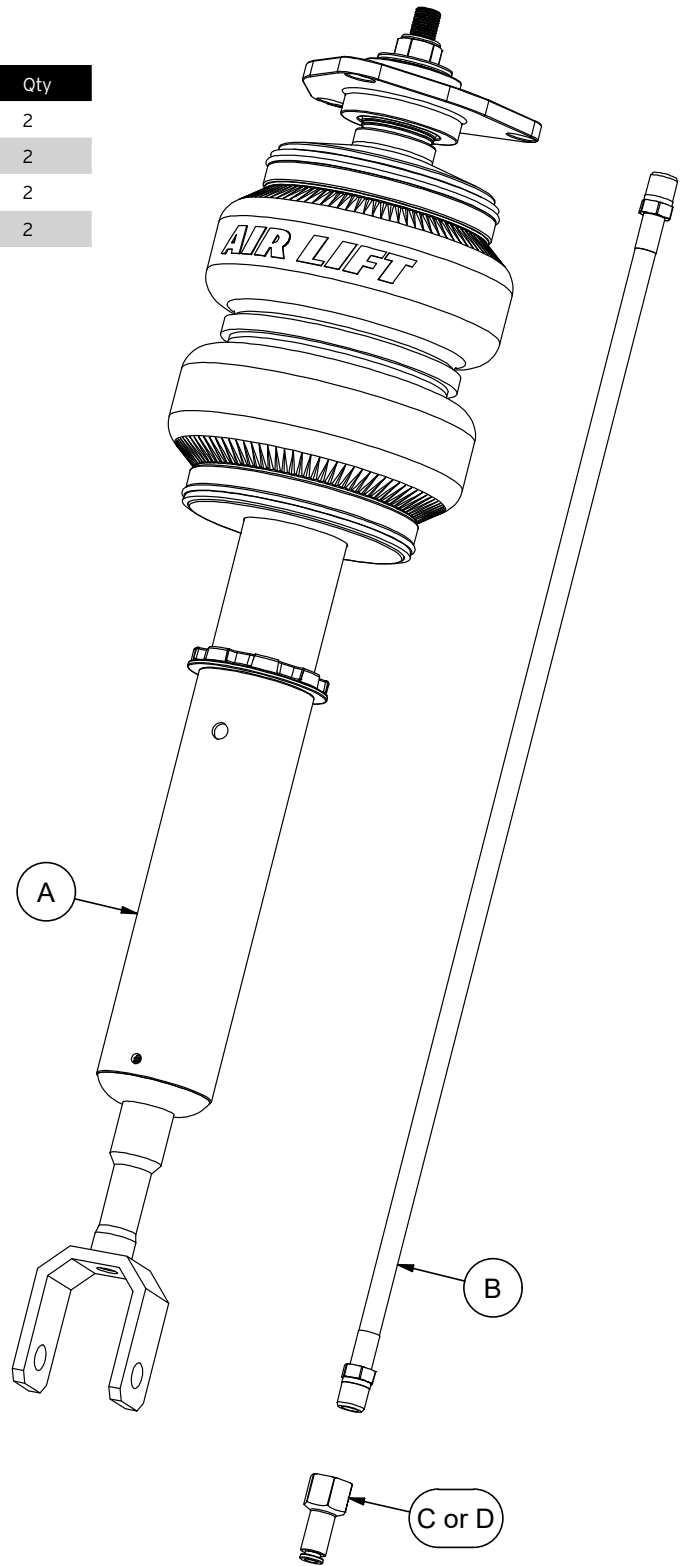

Fig. 1



Missing or damaged parts? Call Air Lift customer service at (800) 248-0892 for a replacement part.

Install the System



NOTE

See important safety notices on page 2.

SECTION 1

PREPARE THE VEHICLE

1. Elevate and support the vehicle with a hoist or safety stands.
2. Remove the front wheel and support the hub assembly. (Fig. 2)



*Representative image

Fig. 2

SECTION 2

STOCK SUSPENSION REMOVAL

1. Support the hub assembly to prevent overextension of suspension components.
2. Remove lower shock bolt from the transverse link (Figs. 3 & 4).

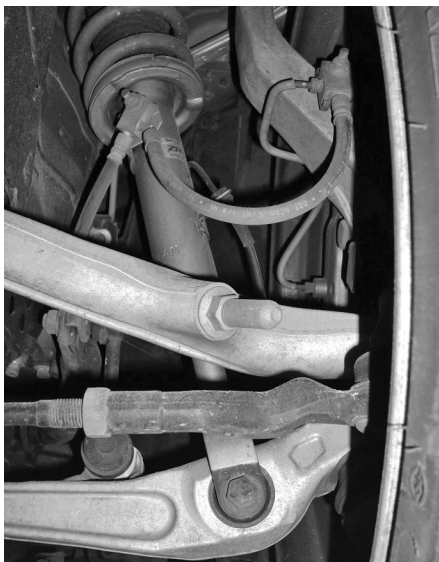

Fig. 3



Fig. 4

3. Unbolt the stabilizer bar from the lower transverse link.
4. Disconnect the wheel speed sensor wire and brake line from the shock (Figs. 5 & 6).

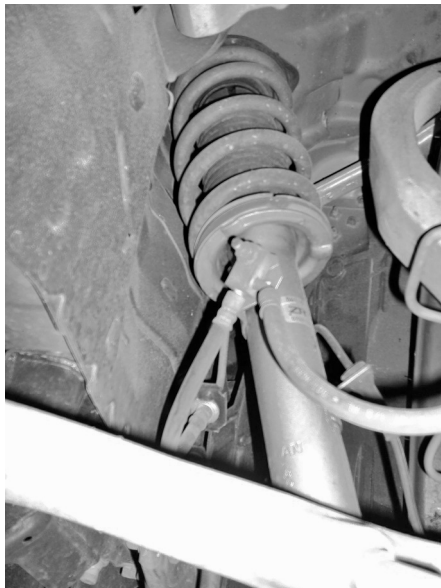

Fig. 5



Fig. 6

5. Within the engine compartment, unbolt and remove the tower brace. Nismo models will require the front support removed as well. (Figs. 7, 8, 9 & 10)



Fig. 7



Fig. 8

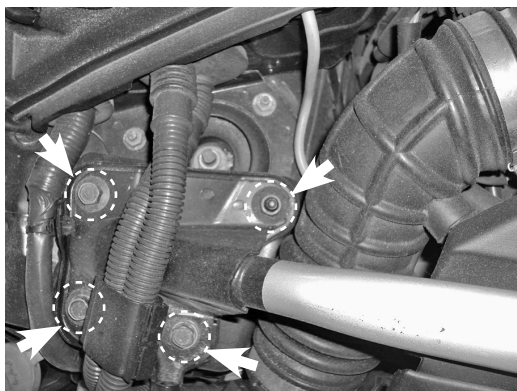

Fig. 9



Fig. 10

6. Unbolt the three upper shock mount bolts and remove the shock assembly from the vehicle.

SECTION 3

INSTALL THE KIT COMPONENTS



PLEASE READ - IMPORTANT INSTALLATION INFORMATION



FOR COIL TO AIR UPGRADE KIT INSTALLATIONS ONLY: Please refer to the included Coil to Air Upgrade Kit installation guide (MN-2000) for details on how to disassemble the coilovers and assemble the air springs.

Also refer to your control system installation guide to ensure the installation of your air suspension system is complete.

1. Begin by installing the leader line (B) into the air spring. Tighten the appropriate fitting (C or D) to the air line (1 3/4 turns beyond hand-tight). Tighten the leader line into the air spring 1 3/4 turns beyond hand-tight. (Fig. 11)

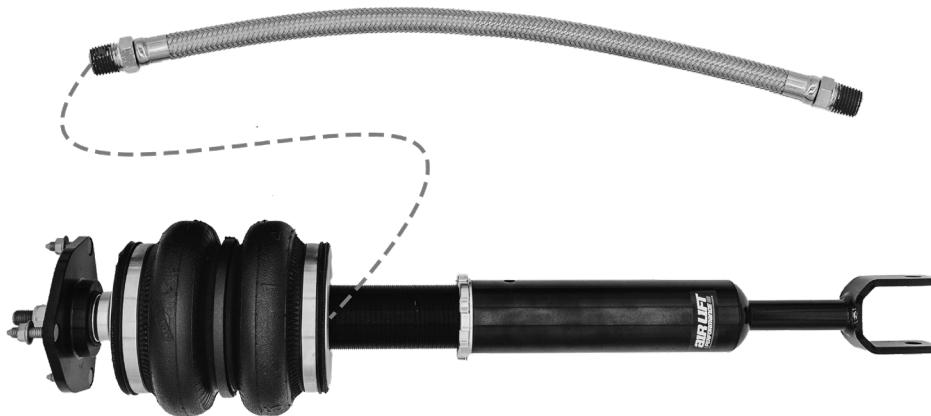

Fig. 11

2. Insert the shock assembly (A) into the shock tower and attach the upper bracket to the chassis. The shock should be installed so that the air spring air port is directed towards the engine compartment. Torque the upper bracket nuts to 39Nm (28 lb.-ft.).
3. Attach the shock fork to the lower transverse link. Do not torque the attaching bolt at this time.
4. Reattach the tower brace and front supports. Torque to 45Nm (33 lb.-ft.).

SECTION 4. ROUTE THE AIR LINES



WARNING

AFTER INSTALLATION, ENSURE ALL ORIGINAL EQUIPMENT VEHICLE SAFETY FEATURES ARE PROPERLY CALIBRATED BY A QUALIFIED TECHNICIAN. CHANGING VEHICLE HEIGHT MAY AFFECT FUNCTIONING OF SAFETY SENSORS AND CAMERAS.

1. Fully compress the suspension using a jack. With the suspension compressed, review the best routing for the air line that is clear of all suspension and steering components.
2. Routing should allow for the suspension to extend and steer without kinking, pulling the line tight, or rubbing on other components. Following the brake line routing is often a good place to start. Check clearances to all other components.



PLEASE READ - IMPORTANT INSTALLATION INFORMATION

Please refer to your control system installation guide for more details on air line routing and to ensure the installation of your air suspension system is complete.

Before Operating

SET THE RIDE HEIGHT

1. Refer to the User Guide supplied with this kit to set up the suspension.

Torque Specifications		
Location	Nm	lb.-ft.
Upper bracket to chassis	39	28
Upper control arms to bracket	70	52
Transverse link to shock clevis	107	79
Transverse link to subframe	130	96
Stabilizer link to transverse link	88	65
Wheels	99-126	73-93
Tower brace	45	33

2. Upon successful completion of the installation, follow these pressure requirements for the air springs.



Suggested Driving Air Pressure



Maximum Air Pressure



CAUTION

FAILURE TO MAINTAIN ADEQUATE MINIMUM PRESSURE (OR PRESSURE PROPORTIONAL TO LOAD) MAY RESULT IN EXCESSIVE BOTTOMING OUT AND **WILL VOID THE WARRANTY.**

CHECK FOR BINDING



CAUTION

MAKE SURE THE FRONT WHEELS ARE STRAIGHT WHEN DEFLATING AND REINFLATING AIR SPRINGS.

1. Inflate and deflate the system (do not exceed 8.6BAR [125 PSI]) to check for clearance or binding issues. With the air springs deflated, check clearances on everything so as not to pinch brake lines, vent tubes, etc. Clear lines if necessary.
2. Inflate the air springs to 5.2-6.2BAR (75-90 PSI) and check all connections for leaks.

INSTALLATION CHECKLIST

- Clearance** – Inflate the air springs to 5.2-6.2BAR (75-90 PSI) and make sure there is at least 13mm (1/2") clearance from anything that might rub against the air spring. This should be checked with the air spring fully inflated and fully deflated.
- Leak** – Inflate the air springs to 5.2-6.2BAR (75-90 PSI) and check all connections for leaks. All leaks must be eliminated before the vehicle is road-tested.
- Heat** – Be sure there is sufficient clearance from heat sources, at least 152mm (6") from air springs and air lines. If a heat shield was included in the kit, install it. If there is no heat shield, but one is required, call Air Lift customer service at **(800) 248-0892**.
- Fastener** – Recheck all bolts for proper torque.
- Road** – Inflate the air springs to recommended driving pressures (see previous page). Drive the vehicle 16km (10 miles) and recheck for clearance, loose fasteners, and air leaks.
- Operating instructions** – If professionally installed, the installer should review the operating instructions with the owner. Be sure to provide the owner with all paperwork that came with the kit.

DAMPING ADJUSTMENT

1. The dampers in this kit have 32 settings, or "clicks," of adjustable compression and rebound damping characteristics. Damping is changed through the damper rod using the supplied adjuster (example shown here) or a 3mm hex key (not included).

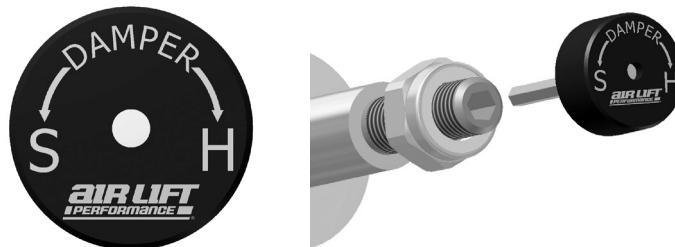

2. Turn the adjuster clockwise (H), and the damping settings are hardened, reducing oscillations and body motion. Turn the adjuster counterclockwise (S), and the damping is softened.
3. Each damper will need to be set after installation and your initial drive, as they are not pre-set. It may take multiple adjustments to dial in your ideal ride. A good starting point is in the middle at 16 clicks from full soft, then drive the vehicle and make adjustments either softer or stiffer.

For more information, refer to the user guide.

Limited Warranty and Return Policy

Air Lift Company provides a limited warranty to the original purchaser of Air Lift Performance Air Suspension kits from the date of original purchase, that the products will be free from defects in workmanship and materials when used on cars and trucks as specified by Air Lift Company and under normal operating conditions, subject to the requirements and exclusions set forth in the full Limited Warranty and Return Policy.

* Full Limited Warranty and Return Policy are available at www.airliftperformance.com/warranty and are subject to change.

WARRANTY REGISTRATION & CLAIMS

- To register your warranty, please visit <https://www.airliftperformance.com/support/warranty-registration/>
- To submit a warranty claim, please visit <https://www.airliftperformance.com/support/submit-warranty-claim/>

Thank you for purchasing Air Lift Performance products!

Need Help?

Contact Air Lift Company Customer Service at (800) 248-0892 or +1 (517) 322-2144 for calls from outside the U.S. and Canada.



Connect by searching for **Air Lift Performance** #LifeonAir

AIR LIFT
PERFORMANCE

2727 Snow Road Lansing, MI 48917 or P.O. Box 80167 Lansing, MI 48908-0167
Toll Free (800) 248-0892 • Local (517) 322-2144 • Fax (517) 322-0240
www.airliftperformance.com



MADE IN USA
WITH GLOBAL
COMPONENTS

Air Lift Company reserves the right to make changes and improvements to its products and publications at any time. For the latest version of this manual, contact Air Lift Company at (800) 248-0892 or visit airliftperformance.com.