



\* Schematische Darstellung

# STILLEGUNGSSATZ

## CANCELLATION KIT

FÜR JEDEN ANSPRUCH DAS RICHTIGE FAHRWERK.

KW automotive GmbH  
Aspachweg 14  
74427 Fichtenberg  
Telefon: +49 7971 9630 - 0  
Telefax: +49 7971 9630 - 191



<b>Einbauhinweise / Installation Instructions</b>			<b><i>KW automotive</i></b>	
Hinweis Nr./ Instruction No.	685 10 248		Erstellt am/ Date	15.10.2020

# ***KW automotive***

**685 10 248**  
**EINBAUHINWEISE**  
**Audi S3 Elektronik Satz**

**685 10 248**  
**INSTALLATION INSTRUCTIONS**  
**Audi S3 Cancellation kit**

<b>Einbauhinweise / Installation Instructions</b>		<b>KW automotive</b>	
---	--	----------------------	--

Hinweis Nr./ Instruction No.	685 10 248	Erstellt am/ Date	15.10.2020
---------------------------------	------------	----------------------	------------

**Vorderachse/  
Front axle:**

Rechte Fahrzeugseite.  
Right vehicle side.

Original Dämpferleitung entlang der Markierungen verlegen und mit Kabelbindern am Kabelbaum befestigen. VA Elektronik Satz mit den mitgelieferten Edge Clips und Kabelbinder an der Karosserie-kante befestigen.

Run the original shock absorber cable along the marked point and fix it on the original wire harness with the supplied cable ties.

Mount the front axle electronic kit with the supplied edge clips and cable ties on the chassis edge.

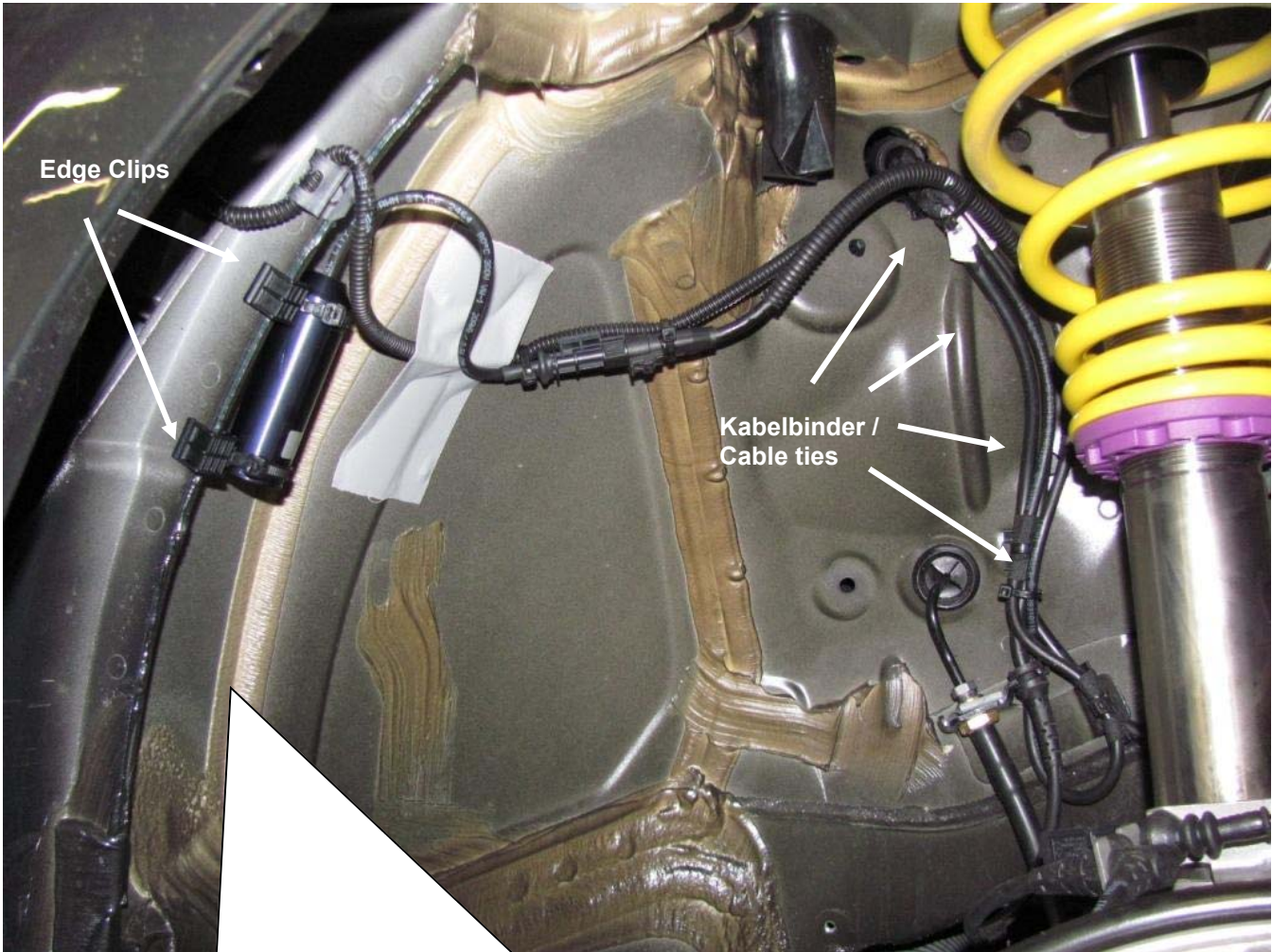

Montageort VA Elektronik Satz / Assembly area front axle electronic kit

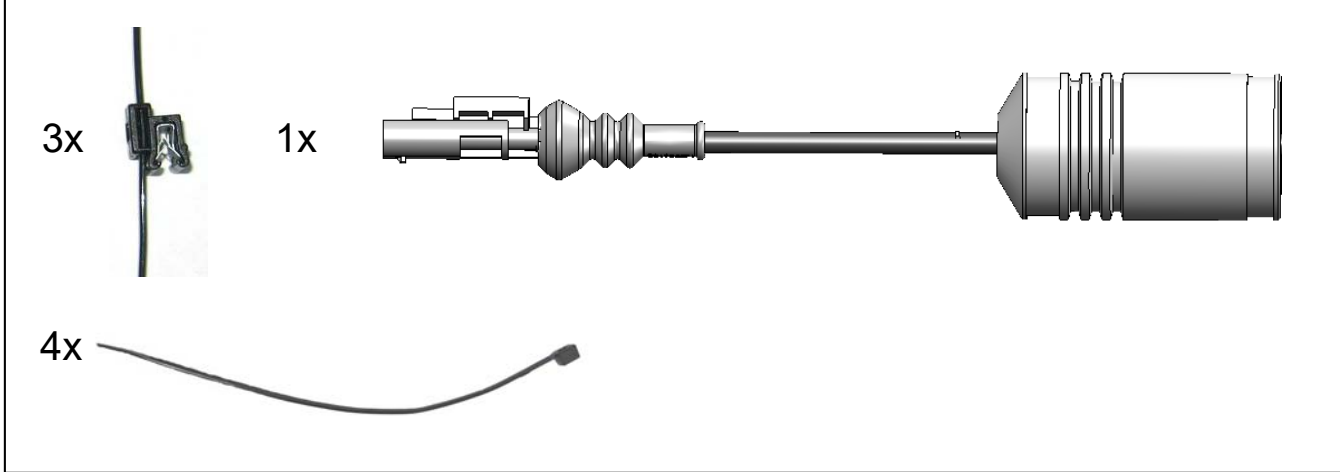

<b>Einbauhinweise / Installation Instructions</b>		<b>KW automotive</b>	
---	--	----------------------	--

Hinweis Nr./ Instruction No.	685 10 248	Erstellt am/ Date	15.10.2020
---------------------------------	------------	----------------------	------------

<b>Vorderachse/ Front axle:</b>	Original Dämpferleitung entlang der Markierungen verlegen und mit Kabelbindern am Kabelbaum befestigen. VA Elektronik Satz mit den mitgelieferten Edge Clips und Kabelbinder an der Karosserie-kante befestigen.
Linke Fahrzeugseite. Left vehicle side.	Run the original shock absorber cable along the marked point and fix it on the original wire harness with the supplied cable ties. Mount the front axle electronic kit with the supplied edge clips and cable ties on the chassis edge.

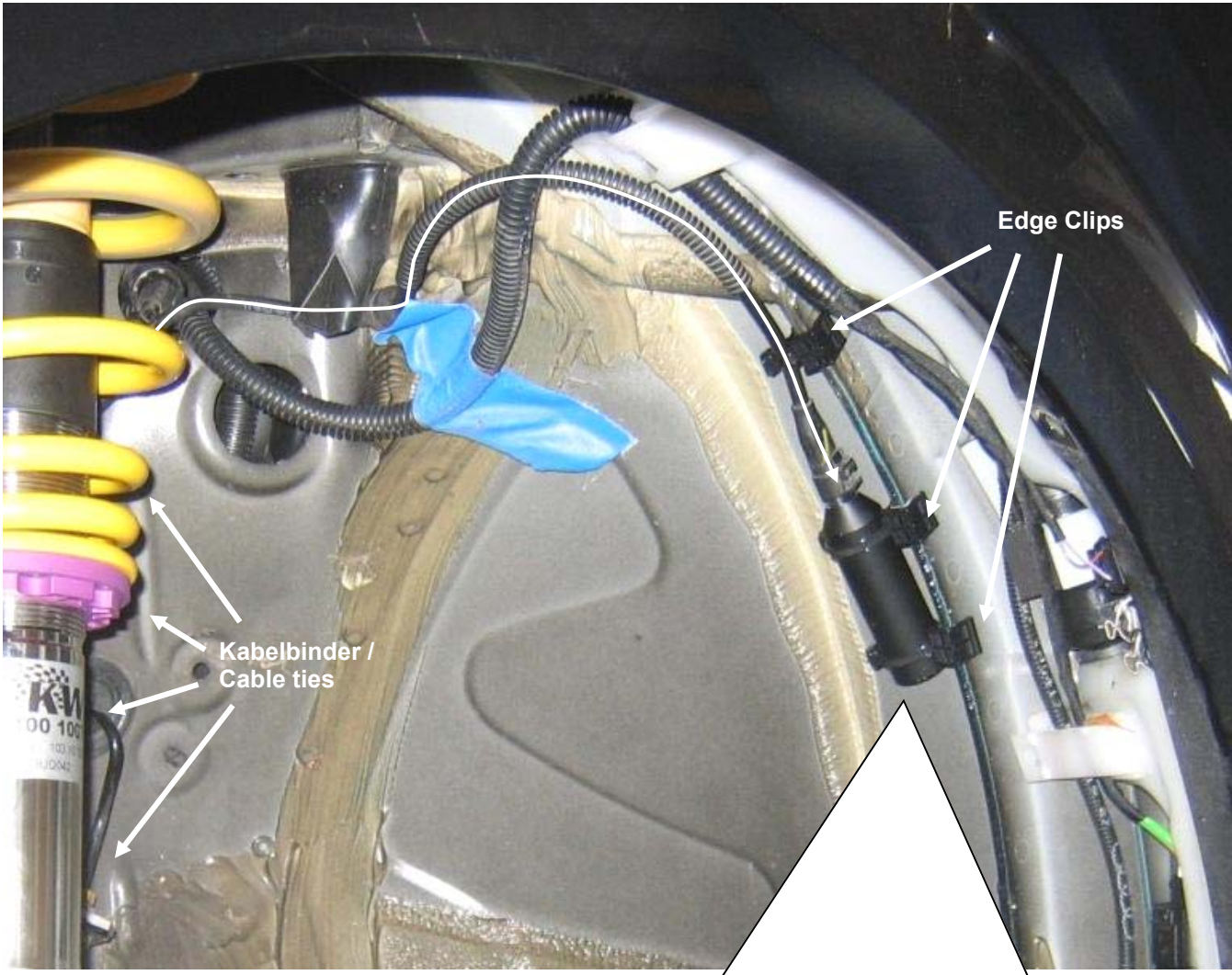

Montageort VA Elektronik Satz / Assembly area front axle electronic kit

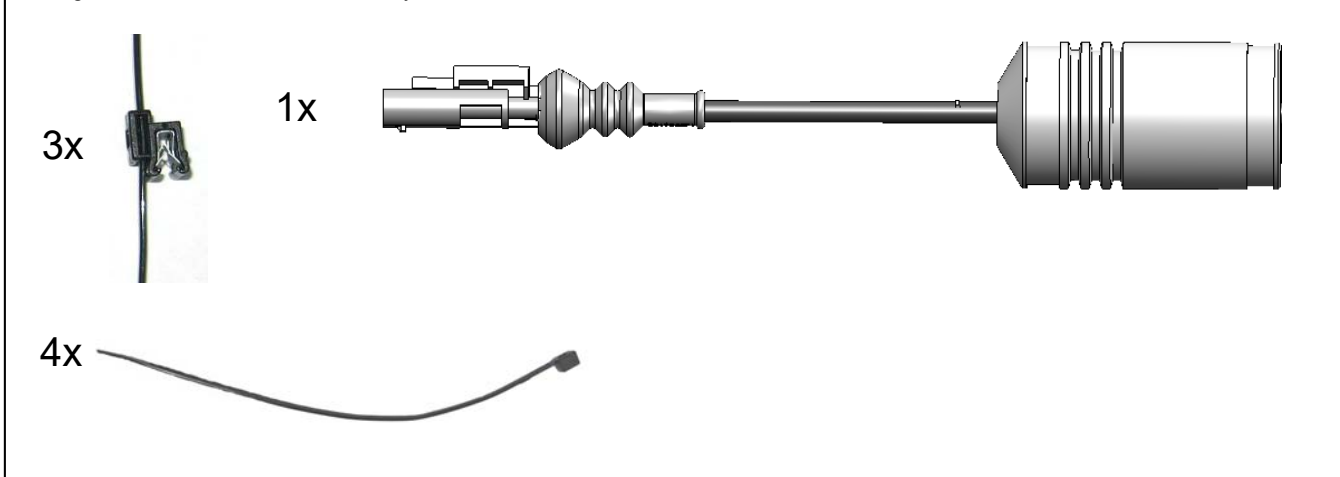

<b>Einbauhinweise / Installation Instructions</b>			<b>KW automotive</b>	
Hinweis Nr./ Instruction No.	685 10 248		Erstellt am/ Date	15.10.2020

**Hinterachse/  
Rear axle:**

Linke Fahrzeugseite.  
Left vehicle side.



Montageort HA Elektronik Satz / Assembly area rear axle electronic kit

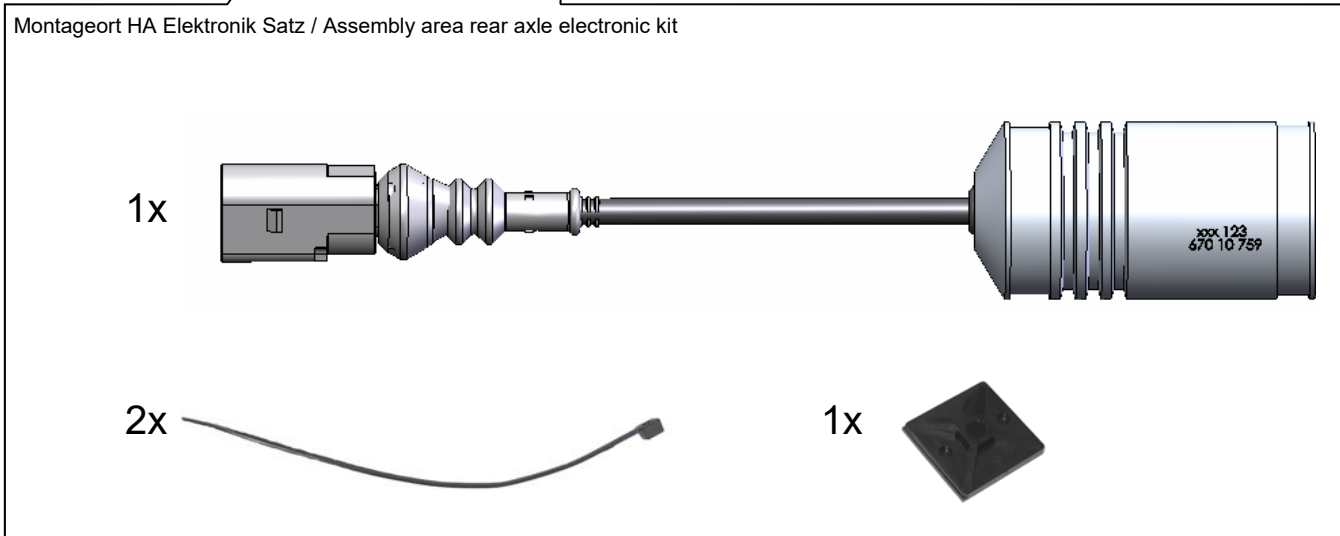

Einbauhinweise / Installation Instructions			KW automotive	
Hinweis Nr./ Instruction No.	685 10 248		Erstellt am/ Date	15.10.2020
<b>Hinterachse/ Rear axle:</b>		Original Dämpferleitung entlang der Markierungen verlegen und mit Kabelbindern am Kabelbaum befestigen. HA Elektronik Satz mit dem mitgelieferten Klebesockel und Kabelbindern an der Karosserie befestigen. <b>WICHTIG: Oberfläche muss Staub- und Fettfrei sein.</b>		
Linke Fahrzeugseite. Left vehicle side.		Run the original shock absorber cable along the marked point and fix it on the original wire harness with the supplied cable ties. Mount the rear axle electronic kit with the supplied adhesive mount and cable ties on the chassis. <b>IMPORTANT: Surface must be cleaned and degreased.</b>		



<b>Einbauhinweise / Installation Instructions</b>		<b>KW automotive</b>	
---	--	----------------------	--

Hinweis Nr./ Instruction No.	685 10 248	Erstellt am/ Date	15.10.2020
---------------------------------	------------	----------------------	------------

<b>Hinterachse/ Rear axle:</b>	Original Dämpferleitung entlang der Markierungen verlegen und mit Kabelbindern am Kabelbaum befestigen. HA Elektronik Satz mit dem mitgelieferten Klebesockel und Kabelbindern an der Karosserie befestigen.
Rechte Fahrzeugseite. Right vehicle side.	Run the original shock absorber cable along the marked point and fix it on the original wire harness with the supplied cable ties. Mount the rear axle electronic kit with the supplied adhesive mount and cable ties on the chassis.

