

FG019

2015+ FORD F150 (EXCL. RAPTOR), 3.5L
ECOBOOST, Y-PIPE WITH CATALYTIC
CONVERTERS

MBRP
P O W E R S P O R T S

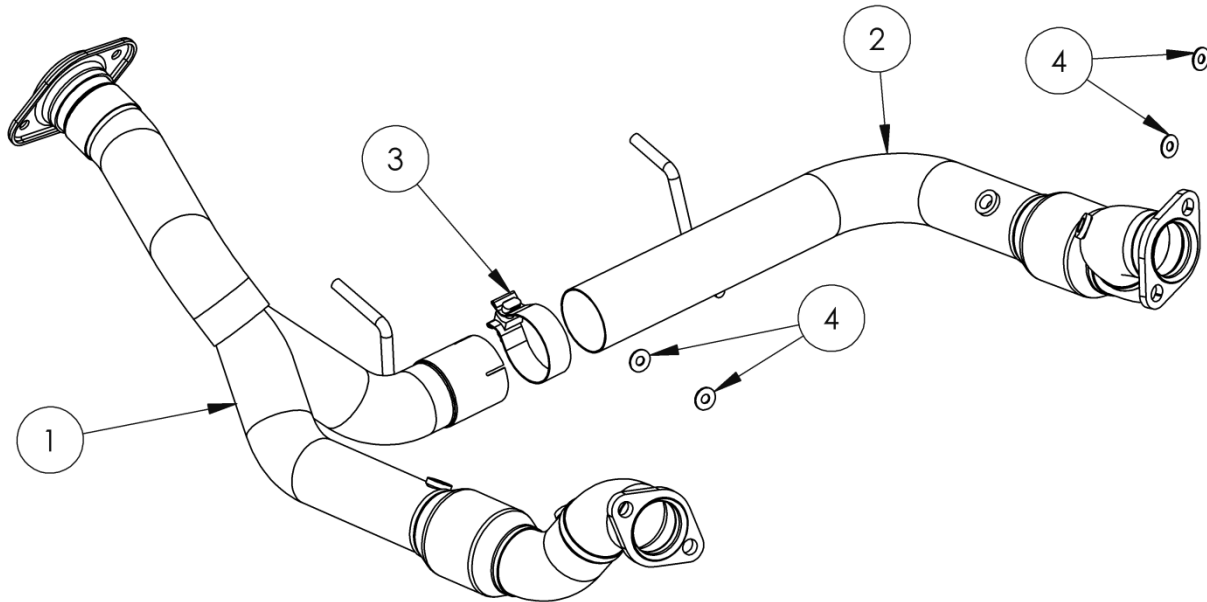

1. Y-PIPE
2. DRIVER-SIDE PIPE
3. BAND CLAMP
4. FLAT WASHER (4 PCS)

**NOTE: A TUNE IS REQUIRED TO TURN OFF CHECK ENGINE LIGHT
NOT LEGAL FOR SALE IN CALIFORNIA**

PLEASE READ BEFORE STARTING INSTALLATION

While MBRP Inc. has made every effort to ensure that all components of this system are of superior quality and properly packaged, it is the installer's responsibility to ensure the following before removal of the factory exhaust:

- that ALL components shown above are present.
- that ALL mating components fit together.
- that there are no damaged components.
- that the system you have purchased is appropriate for your vehicle year, model and configuration.
- that the system will not interfere with any modifications previously installed or planned.
- that you have read and understand these instructions.

If you have any questions or are uncertain about any aspect of the installation of this system to your vehicle please contact your dealer before commencing installation.

Removal of Stock Pipes



Figure 1

1. Apply a penetrating lubricant liberally to all exhaust fasteners, rubber isolators, and sensors.

2. Remove the two bolts attaching the factory exhaust system to the Y-Pipe. You may be able to move the factory extension pipe off to the side, if not, you may need to remove the extension pipe or the entire exhaust.

Refer to Figure 1.



Figure 2

3. Carefully remove all four oxygen sensors.

4. Remove the two turbo outlet flange nuts on each manifold. Save the nuts for the installation

Refer to Figures 2 (Driver-Side) and 3 (Passenger-Side).

5. The transmission cross-member has to be removed to permit access to the existing Y-Pipe and to install the new Y-Pipe. Remove the two nuts from the bottom of the transmission mount. The **transmission will need to be supported** while the cross member is removed. Remove the heat shield bolts (one each side) and the cross-member bolts (circled – two each side) and remove the cross-member.

Refer to Figure 4.



Figure 3

6. Remove the transmission mount / exhaust hanger assembly from the transmission. It is necessary to remove the exhaust hanger bolt (arrow) on the driver-side to remove the mount bolts.

Refer to Figures 5.



Figure 4

7. Carefully lower the stock Y-pipe and remove from the vehicle.

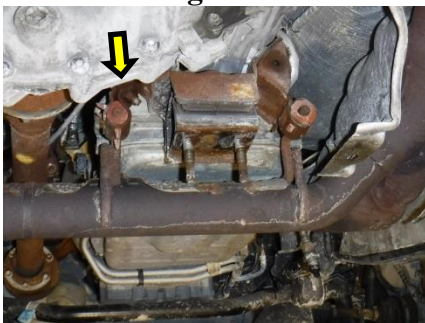

Figure 5

Installation of MBRP Powersports Exhaust



Figure 6

1. Loosely install the **Band Clamp** and insert the **Driver-side Pipe** into the **Y-Pipe**. Note the orientation of the **Band Clamp**.
Refer to Figure 6 and Page 1.

2. Carefully raise the assembled **Y-Pipe** into place and loosely install onto the turbo outlets using the **Flat Washers** and factory flange nuts. Be careful not to entrap or damage any of the oxygen sensors or wiring.
Refer to Figure 7.



Figure 7

3. Install the transmission mount / exhaust hanger assembly onto the **Y-Pipe Hangers** and onto the transmission.

4. Re-install the transmission cross-member and heat shields. Remove support from transmission so that it is supported by the factory mounts only. Replace the transmission mount nuts.
Refer to Figure 8.

5. Check for clearances and alignment of the **Y-Pipe** at the turbo outlets and hangers.

6. Tighten the factory flange nuts at the turbo outlets. Take care to ensure the pipe seats onto the turbo outlet and that the **Flanges** are flat and centered on the studs, tightening each side down an equal amount.
Refer to Figure 7.

7. Tighten the **Band Clamp**.
Refer to Figure 8.

8. Re-install the oxygen sensors in their respective locations. Take care not to damage or stress any of the wiring.

9. Re-install the cat-back exhaust.

10. Check along the whole length of the exhaust system to ensure that there is adequate clearance around the frame, body, fuel and brake lines or any wiring. If any interference is detected, relocate or adjust.



Figure 8

Congratulations!

You are ready to begin experiencing the improved power, sound and driving experience of your MBRP Powersports Performance Exhaust.

We know you will enjoy your purchase!