



### **IMPORTANT! READ THIS FIRST!**

Installation of shock absorbers or other suspension components requires special tools and expert knowledge. Accordingly, installation of all BILSTEIN products must be performed by a professional automotive suspension technician.

When replacing other brands, BILSTEIN shock absorbers or other suspension components should always be installed as a set. All BILSTEIN products must only be used for the specific, intended application as indicated in the application guide. **Any use of any BILSTEIN product other than for its intended use may result in serious bodily injury or death.**

Always use a chassis hoist for the installation of BILSTEIN products and make certain that the raised vehicle is securely attached to the hoist and/or supported to prevent the vehicle from slipping, falling, or moving during the installation process.

**If you install any BILSTEIN product without the necessary special tools, expertise, and chassis hoist, you may subject yourself to the risk of serious bodily injury or death.**

BILSTEIN shock absorbers are gas-filled and are highly pressurized.

- Never place any BILSTEIN shock absorbers in a vise or use a clamp on any BILSTEIN shock absorber.
- Never apply heat near any BILSTEIN shock absorber.
- Never attempt to open or repair any BILSTEIN product, in order to prevent **serious bodily injury or death.**

Any attempt to misuse, misapply, modify, or tamper with any BILSTEIN suspension product voids any warranty and **may result in serious bodily injury or death.**

While installing any BILSTEIN product:

- Do not use impact tools for loosening or tightening fasteners, because this may destroy the screw threads.
- Self-locking fasteners must only be used **once!**
- Reuse original equipment components only if they are in good condition, otherwise replace them with new components.
- Never remove the slight film of oil on the shock absorber piston rod and seal.
- All mounting fasteners for shock absorbers and other suspension components must be securely tightened before tension is placed on the suspension system, unless otherwise specified in the manufacturer's service manual or in this instruction.

After installing any BILSTEIN product:

- The suspension caster and camber must be checked and/or adjusted to comply with the vehicle manufacturer's specifications.
- The (load dependent) brake compensator and the anti-lock brake system must be checked and/or reset to comply with the vehicle manufacturer's specifications.
- The headlight aim must be checked and adjusted. Or, if applicable, adaptive headlights must be checked and recalibrated to comply with the vehicle manufacturer's specifications.
- If applicable, any/all Advanced Driver Assistance Systems (ADAS) must be checked and recalibrated to comply with the vehicle manufacturer's specifications.

### **CAUTION for COILOVER TYPE SUSPENSIONS!!!**

**If disassembling a coilover type suspension, refer to the vehicle manufacturer's service manual for proper procedures. The coil spring is preloaded and must be compressed with a spring compressor to release load before the upper mount is disassembled. Failure to follow the vehicle manufacturer's procedures may cause serious injury or death, and may damage the vehicle.**

### **IMPORTANT!!!**

**This BILSTEIN product may or may not be compatible with non-BILSTEIN aftermarket products and/or vehicle modifications. It is the responsibility of the professional automotive suspension technician performing the installation to identify any non-OEM components and/or modifications on the vehicle that may interact with the suspension system. These must be evaluated for any potential physical static or dynamic interference with and/or effect on the function of this BILSTEIN product.**

# E-WM05-0010009AA MOUNTING INSTRUCTION



**IMPORTANT:**

**PLACE CIRCLIP IN APPROPRIATE GROOVE TO ADJUST RIDE HEIGHT (B8 5100 ONLY).**

Use appropriate tools to move the circlip. Ensure that the circlip is fully seated in the groove after moving it (you should be able to rotate it manually in the groove). Install the supplied spring seat in the direction shown only. The circlip must fit completely in the groove inside spring seat (DETAIL A). **Improper installation will cause permanent damage to the shock!**

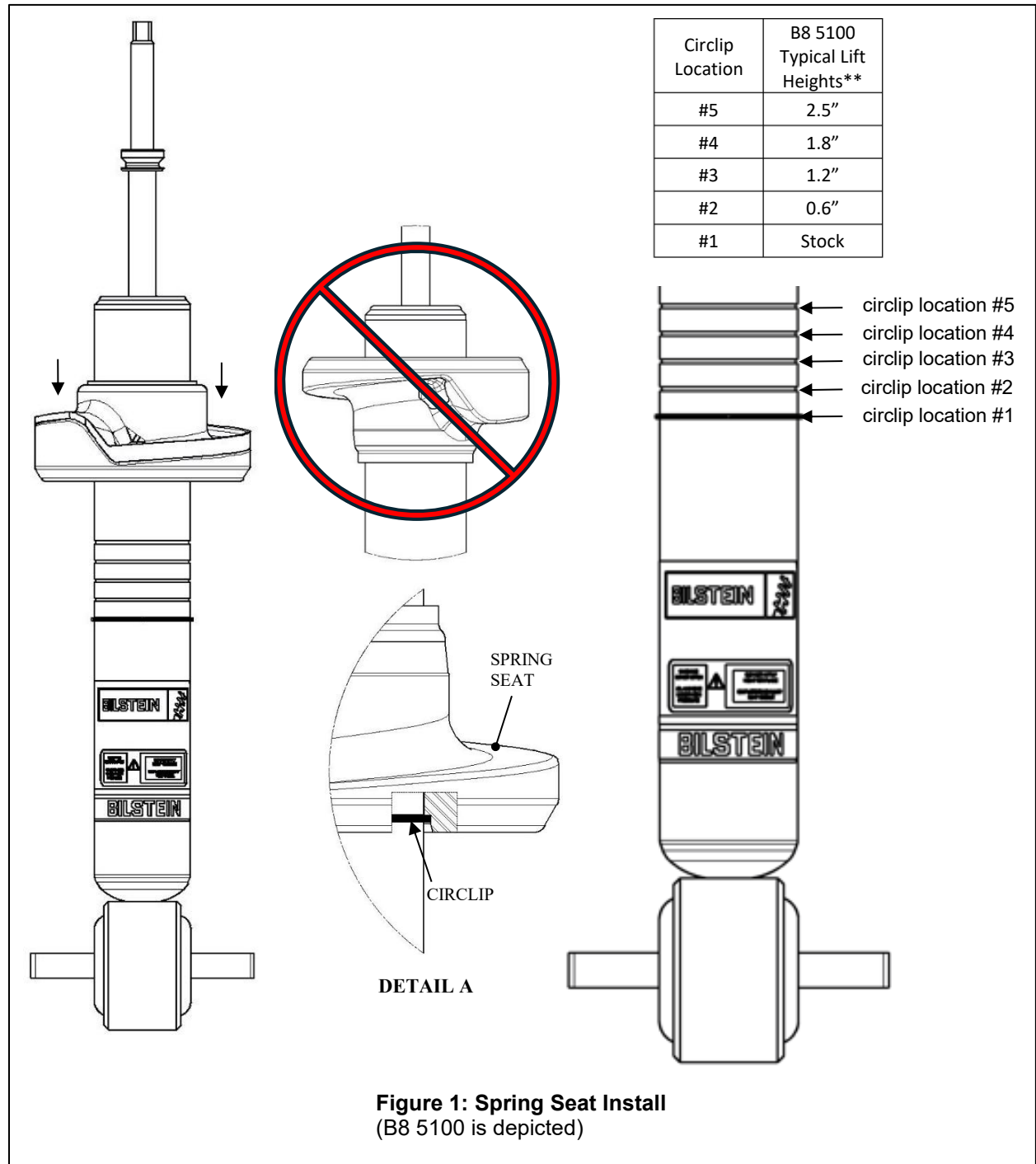

\*\* Lift heights indicated are typical. Actual lift height is influenced by which factory suspension the vehicle is equipped with and its condition; optional equipment and accessories on your vehicle, and other vehicle



modifications such as replacement coil springs, wheel and tire combinations, etc. Modifying/lifting the suspension to your vehicle may raise its center of gravity and may make it more susceptible to loss of control and/or rollover, which may result in death or serious injury. We strongly recommend that you offset the loss of rollover resistance as much as possible by increasing tire track width. Wear seat belts at all times and avoid situations where a side rollover may occur.

**Instructions for disassembly of OE shock absorber module:**

- A. Remove the existing shock and spring unit from the vehicle following all procedures in the vehicle manufacturer's service manual.
- B. Note the clocking of the lower T bar mount relative to the studs on the upper mount (important for reassembly and installation).
- C. Using an appropriate spring compressor, compress the spring until it can be rotated freely by hand. Then, disassemble the shock and spring unit.

**Instructions for assembly of Bilstein B6 4600 or B8 5100 shock absorber module:**

B6 4600: Skip steps D-F.

B8 5100: Skip steps D-E if using circlip locations #1 - #2. If you're using circlip location #3-5, continue to step D. Trimming the OE dust boot is only necessary if circlip location #3-5 is being used.

- D. Remove the OE dust boot and OE rubber isolator/ spring adapter from the top mount plate.
- E. Using scissors, carefully cut the OE dust boot along the dotted line shown below in Figure 2:

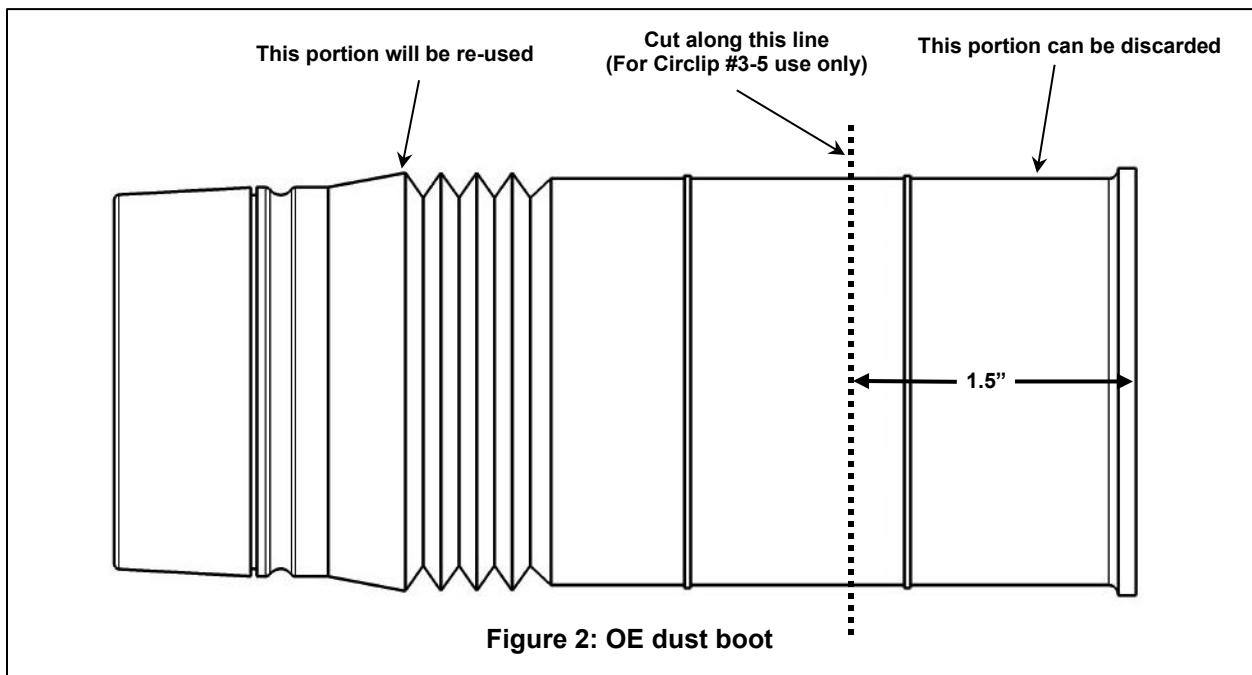



**[Refer to Figure 1 on page 2 for steps F-G]**

- F. Select desired lift height by seating the circlip in the appropriate circlip location.
- G. Install the supplied spring seat on to the new Bilstein shock. Install the spring seat in the direction shown only. The circlip must fit completely in the groove inside spring seat (see DETAIL A, in Figure 1 on page 2). Improper installation will cause permanent damage to the shock.
- H. Using an appropriate spring compressor, compress the OE spring and assemble it with the new Bilstein shock.

**[Refer to Figure 3 on page 5 for steps I-P]**

- I. Temporarily remove the supplied rod adapter from the Bilstein shock. Then, install the OE dust boot & jounce bumper assembly, the supplied rod adapter, OE rubber isolator/ spring adapter, and OE top mount plate over the threaded stem on the new Bilstein shock and on top of the spring, as shown in Figure 3 on page 5.
- J. Rotate the OE spring until the end of the top coil is seated into the ramp of the OE rubber isolator/ spring adapter.
- K. Rotate the shock so the lower T bar mount is aligned with the upper mount studs as noted in step B.
- L. Install the supplied new locknut and tighten to 45 N·m (34 lb·ft). Use a 7mm wrench to keep the piston rod from rotating while torquing the lock nut.

**\*\*\*\*DO NOT USE AN IMPACT WRENCH TO TIGHTEN THE LOCK NUT! \*\*\*\***

- M. Release the spring compressor while ensuring that the end of the top coil remains seated in the OE rubber isolator/ spring adapter.
- N. Install the assembly on to the vehicle and tighten all fasteners to the vehicle manufacturer's specifications- with exception to the lower T bar bolts. Install the supplied lower T bar bolts down through the T bar and control arm. Then install the supplied flange lock nuts on to the T-Bar bolts and tighten the lock nuts to 90 N·m (66 lb·ft). Do not re-use the original lock nuts.
- O. Check wheel alignment. If necessary, adjust to the vehicle manufacturer's specifications. This completes the installation.

# E-WM05-0010009AA MOUNTING INSTRUCTION

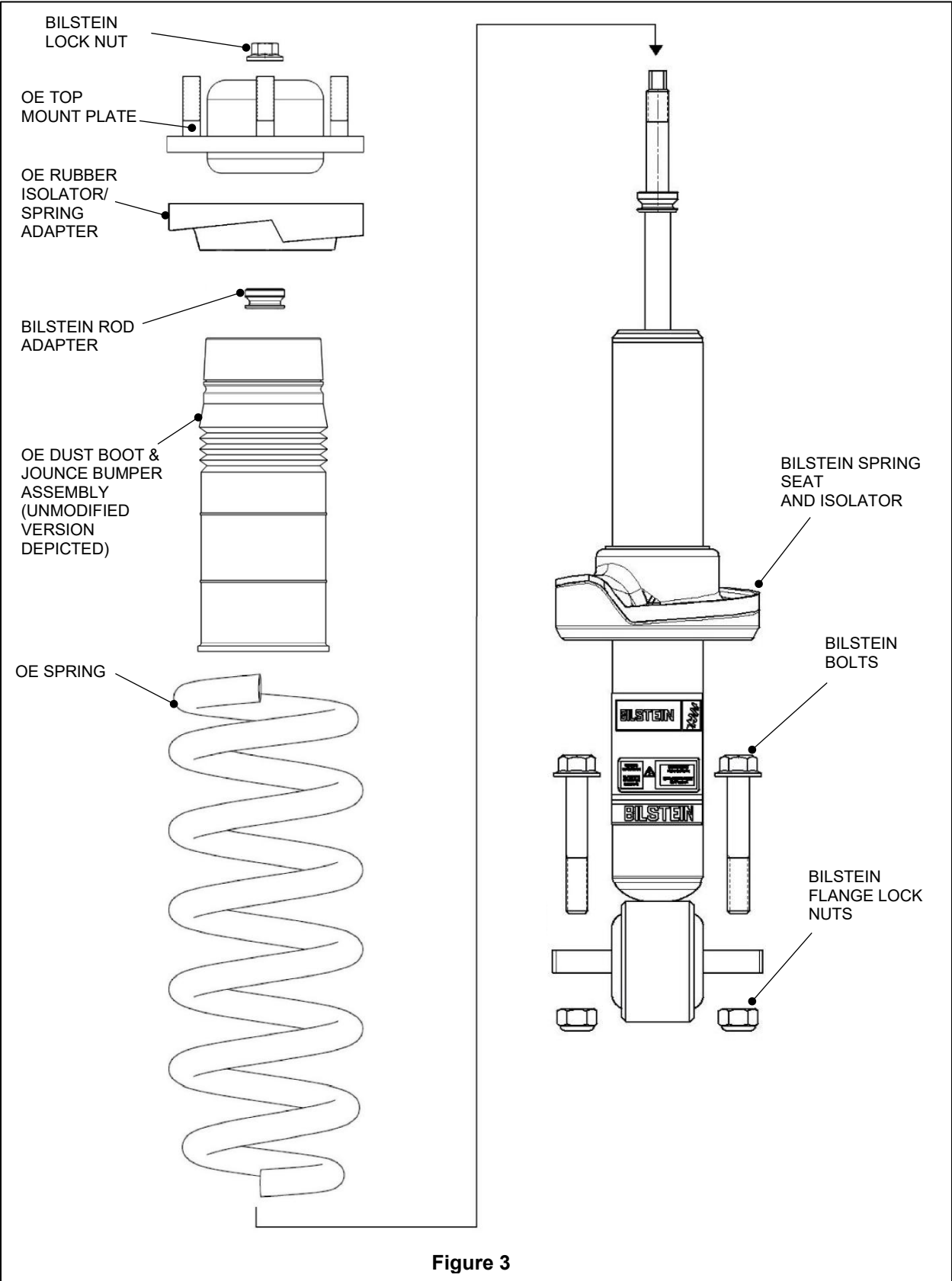

Figure 3