

**D660-0099**



**DINAN**

**FREEFLOW EXHAUST; G01/G02 X3/X4 M40i**

**INSTALLATION**

**06252026**



---

2018-24 G01 X3 M40i  
2019-25 G02 X4 M40i

Notes:

These instructions were written on a North American specification G01 X3 M40i, but other models like the G02 X4 M40i are similar.

When disassembling the car, be sure to keep all fasteners so they can be reused. It is recommended that you get some kind of compartmented tray to organize the fasteners, such as a fishing tackle box or several large ice cube trays. Fasteners that are not reused for reinstallation are noted in the instructions. If a fastener is listed with an additional tightening sequence (such as an angle after a torque specification), it is a torque-to-yield fastener and is recommended to be replaced.

All directions used in this manual (right, left, front, etc.) are based on if you were sitting in the drivers seat of the car.

These instructions assume that you have basic mechanical skills and several varieties of basic hand tools in order to install the kit. If you have any questions about the install, feel free to contact your Dinan representative.



1) Place the vehicle on a lift or securely on jackstands.

2) Remove the ten 10mm screws from the panel between the bottom of the rear bumper and the exhaust heat shield, and then remove the panel from the car.

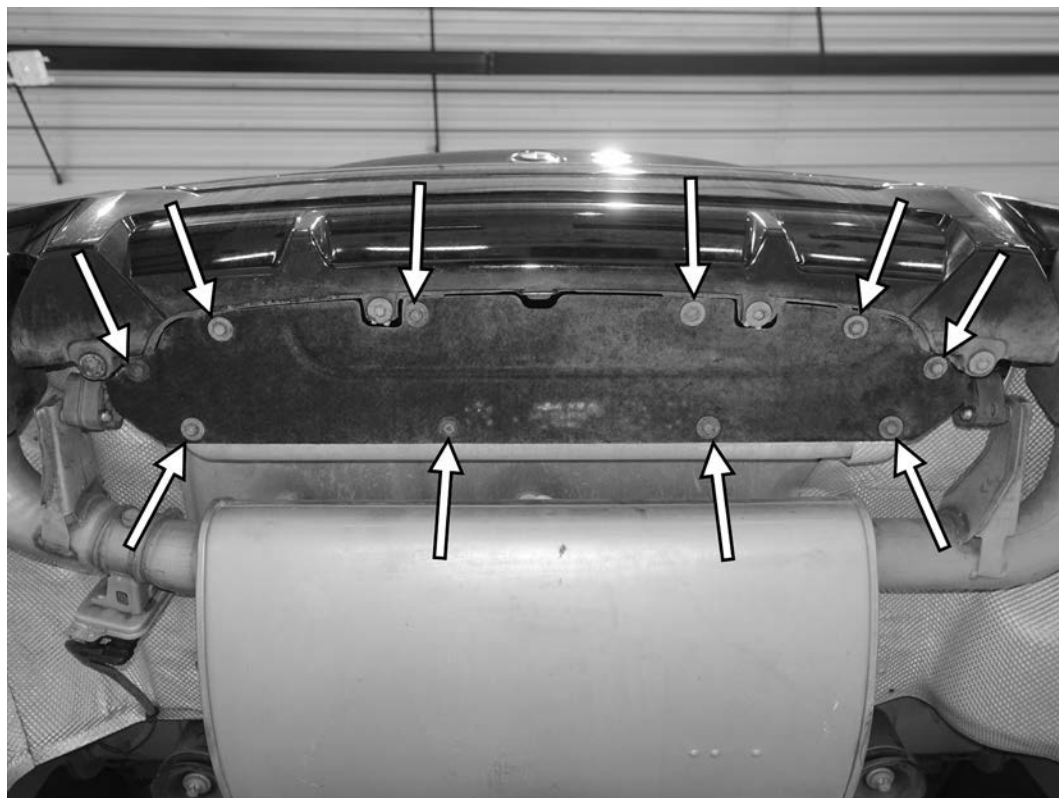

D660-0099



3) From the front side of the rear wheel well, remove the two 10mm screws holding the rear wheel well liner and middle underbody panels. Repeat this step on the left side of the car.

4) Remove the twelve 10mm screws holding the right rear underbody panel to the bottom of the car. Remove the middle screws last so the panel does not fall down. Then, after noting how the panel interacts with the panel just forward of it, slide the panel back and remove it from the car. Repeat this step on the left rear underbody panel.

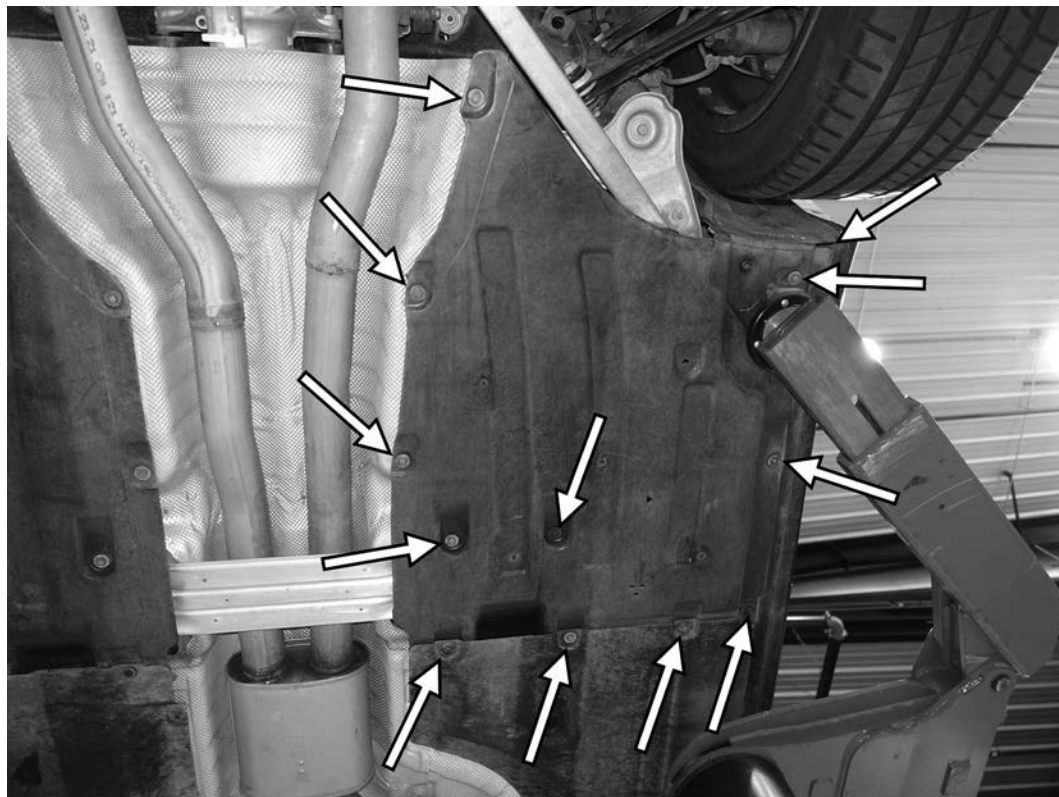

**D660-0099**

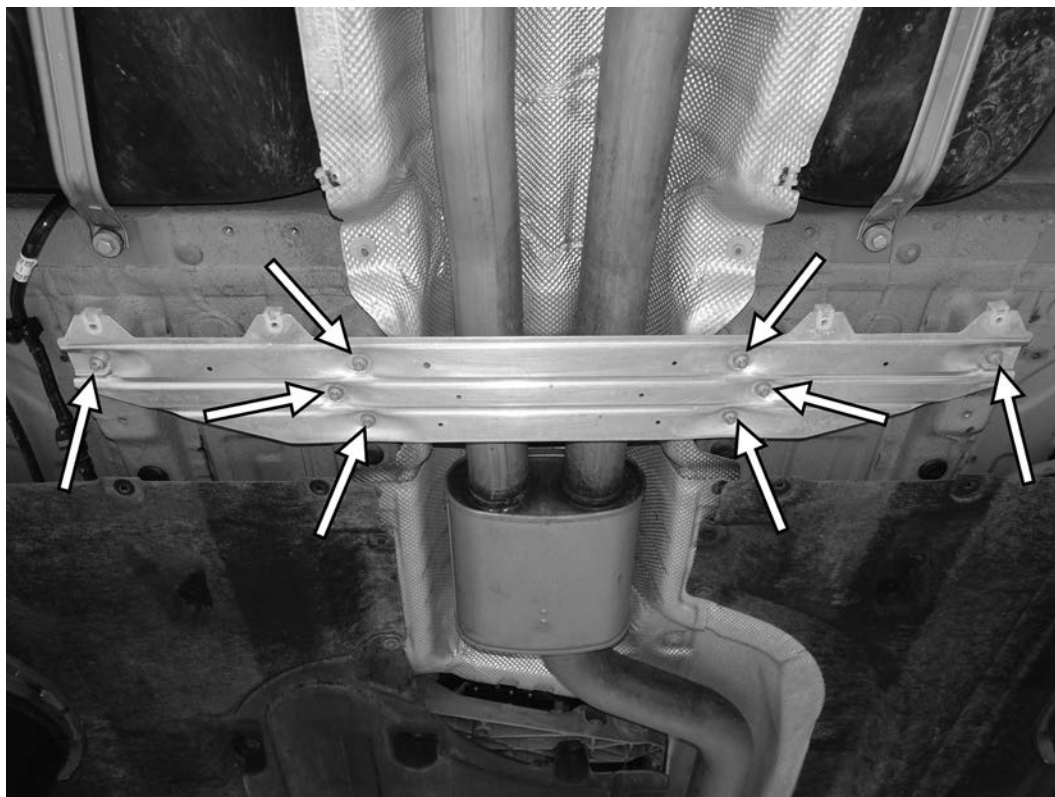

5) Remove the eight E10 external torx screws from the crossbrace at the center of the car. Remove the crossbrace from the car.

6) Loosen, but do not fully remove, the two rearmost 13mm screws holding the chassis stiffening brace to the vertical bracket behind the subframe.

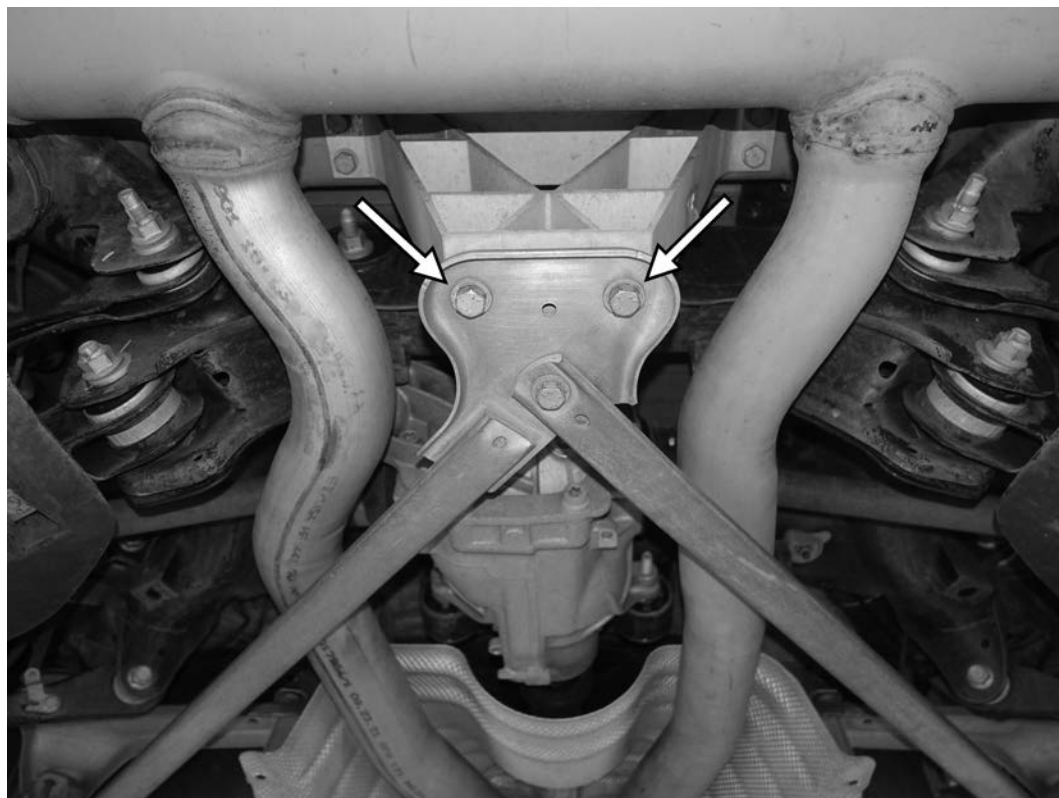

**D660-0099**

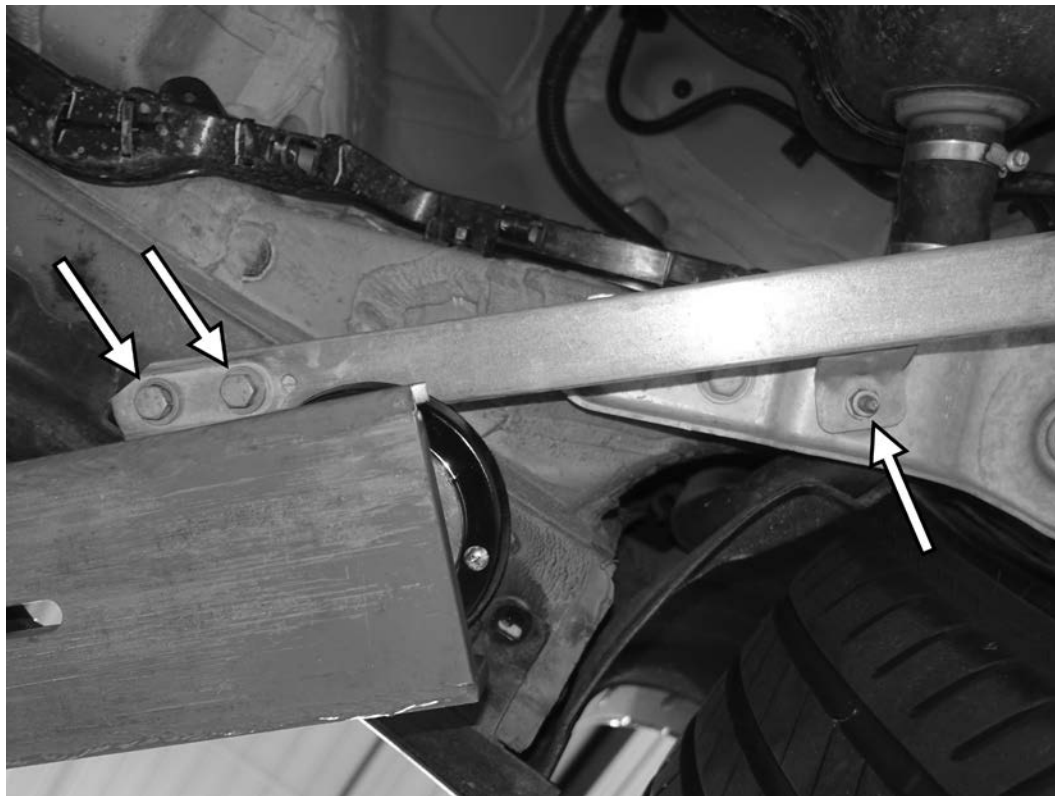

7) Remove the two 13mm screws from the front side of the chassis stiffening brace, and then removed the one 13mm nut from the middle bracket on the braces. Repeat these steps on the right side side of the car. Remove the two rear 13mm screws previously loosened from the rear vertical brace, and remove the stiffening braces from the car.

8) Disconnect the electrical connector to the factory exhaust valve motor, located on the left side of the exhaust by the rear muffler.



**D660-0099**

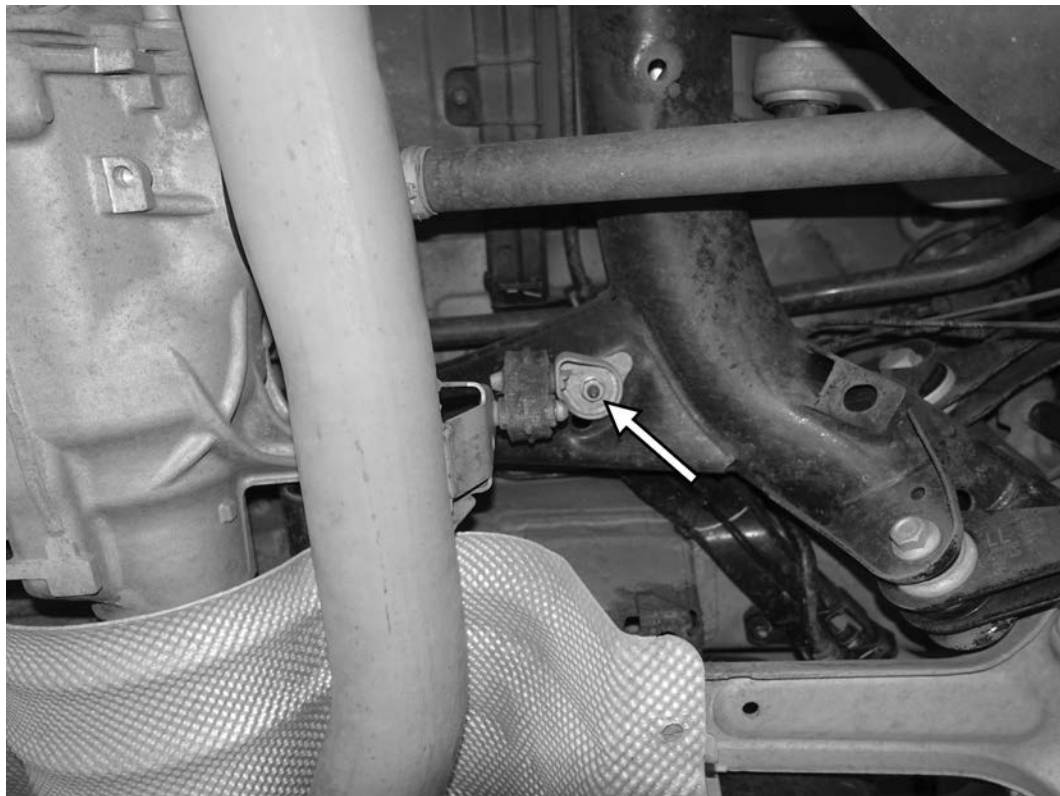

9) Remove the 13mm nut holding the right middle exhaust hanger to the rear subframe, just in front of the rear axle shafts. Repeat this set on the corresponding hanger on the left side of the car.

10) Loosen, but do not remove the 13mm nut holding the front side of the exhaust to the downpipe of the car.

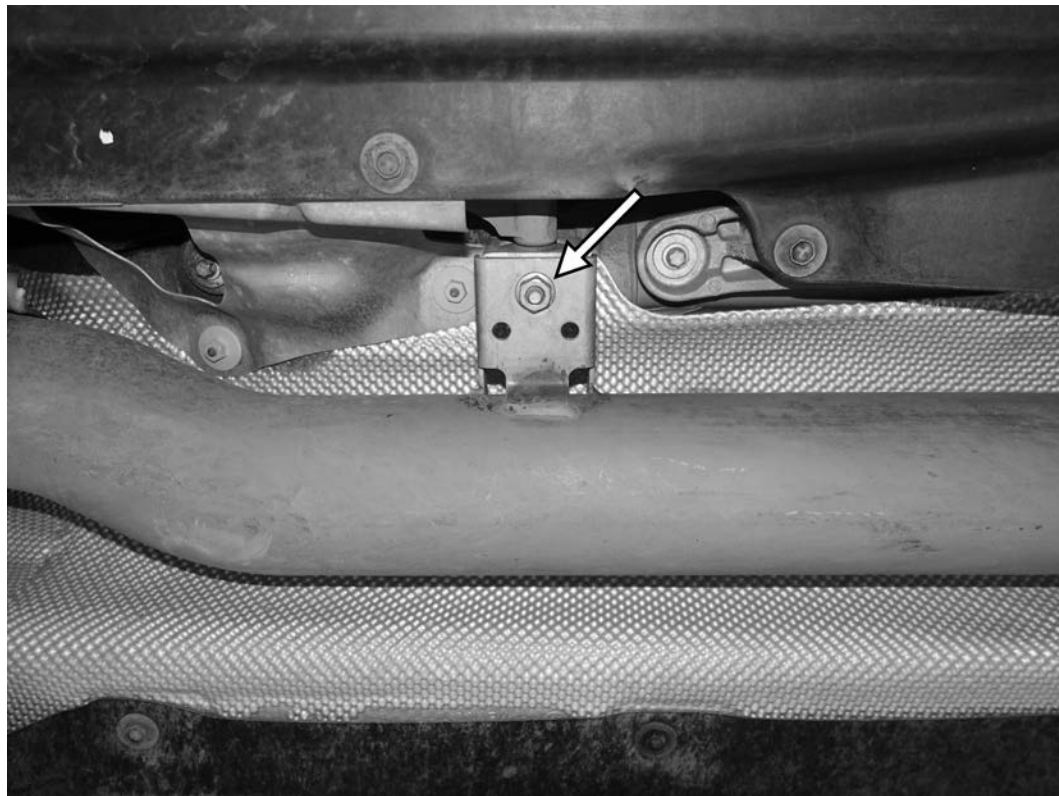

**D660-0099**

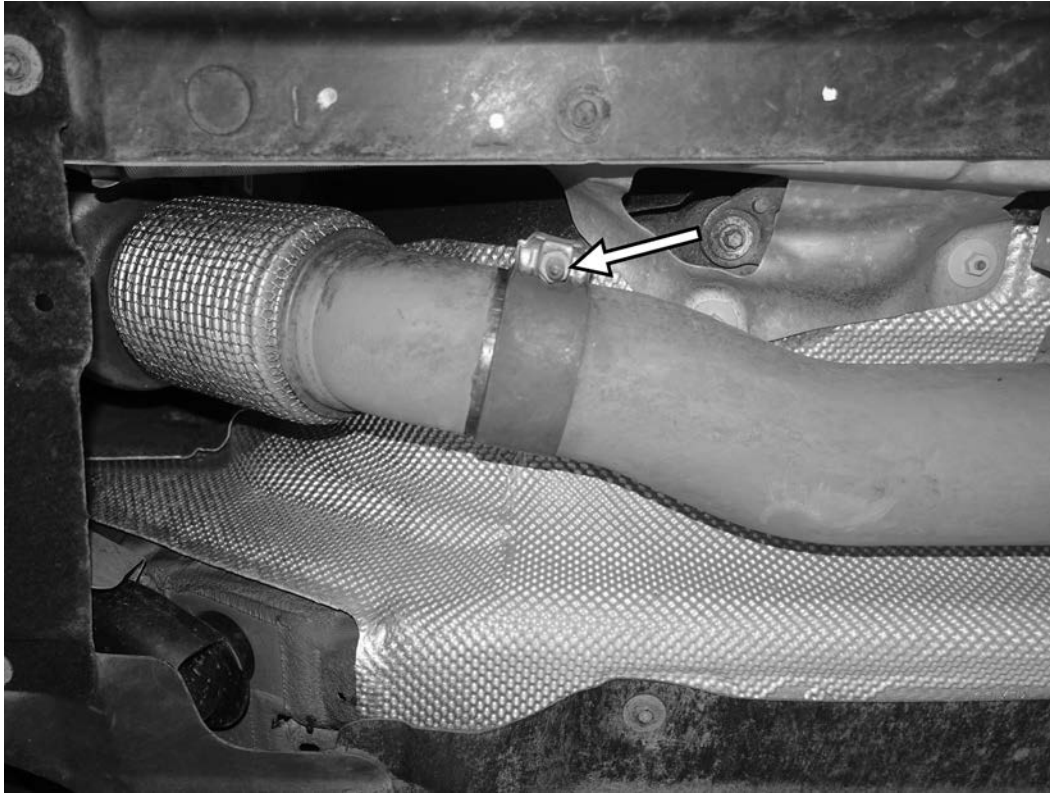

11) Loosen the 13mm nut on the clamp holding the front side of the exhaust to the downpipe. Separate the clamp from the clamp from the exhaust.

12) Support the rear muffler with a jack or an assistant. Remove the two 13mm nuts holding the rear exhaust hanger brackets to the chassis.



**D660-0099**

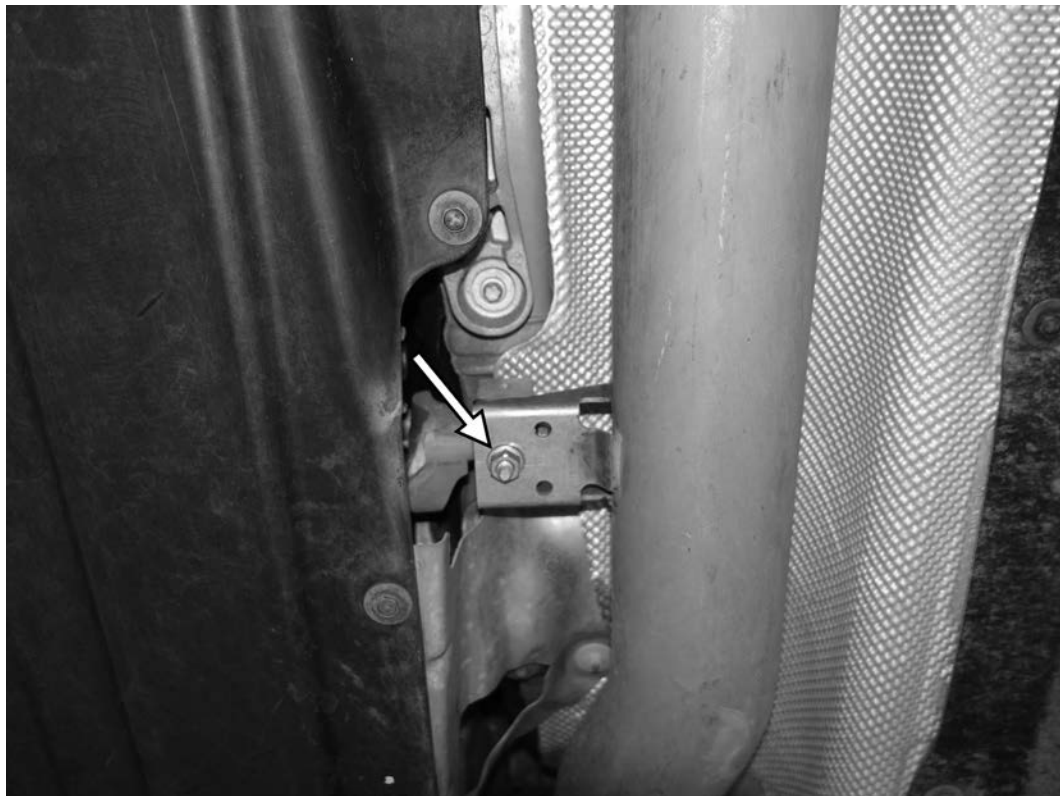

13) With an assistant holding the rear muffler of the car, remove the previously loosened 13mm nut from the front hanger of the exhaust. Separate and lower the exhaust from downpipe, and remove the full exhaust system from the car.

14) Install the front section of the Dinan exhaust pipe to the stock downpipe with the supplied clamp with the smallest diameter of the three supplied. Loosely install the factory 13mm nut to the front factory hanger. Tighten the 15mm nut on the clamp enough to where the exhaust can still be manipulated, but not fully tightened.



**D660-0099**

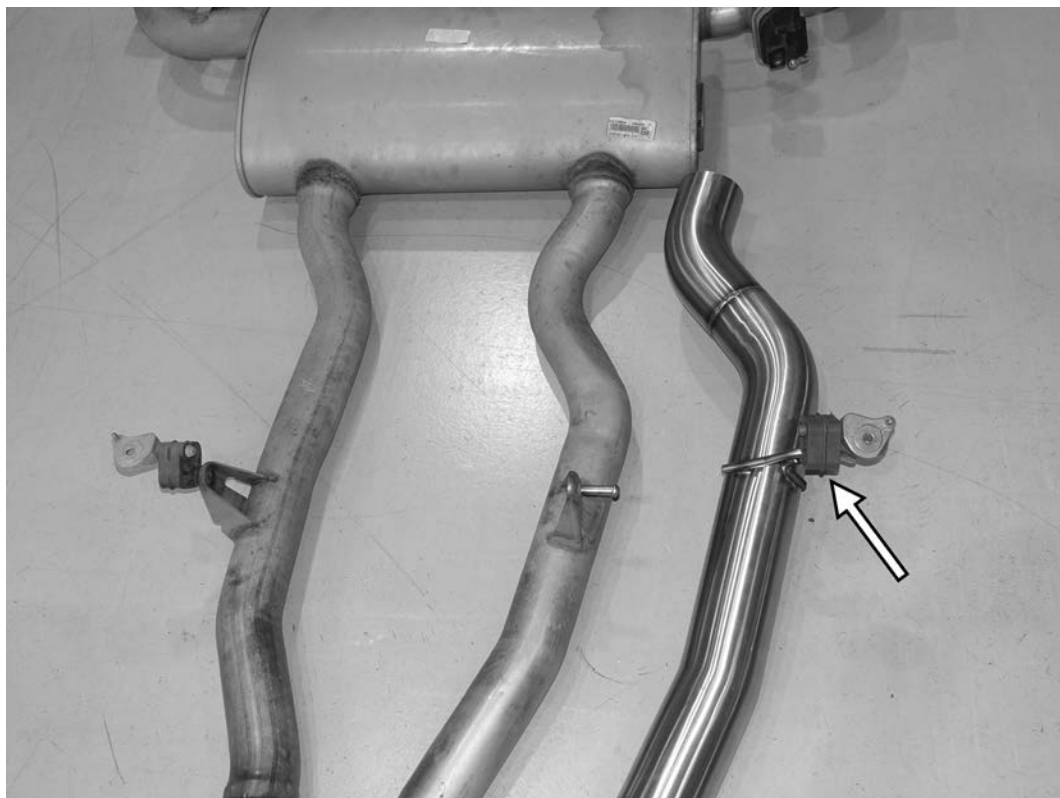

15) Place the Dinan exhaust mid-section next to the left side of the factory exhaust. Swap the factory exhaust hanger from the left side of the factory exhaust to the hanger on the Dinan midsection.

16) With one of the two bigger supplied clamps, install the Dinan mid-section to the back of the Dinan front section. Install the 13mm nut to secure the factory hanger to the chassis. Tighten the 15mm nut on the clamp enough to where the exhaust can still be manipulated, but not fully tightened.

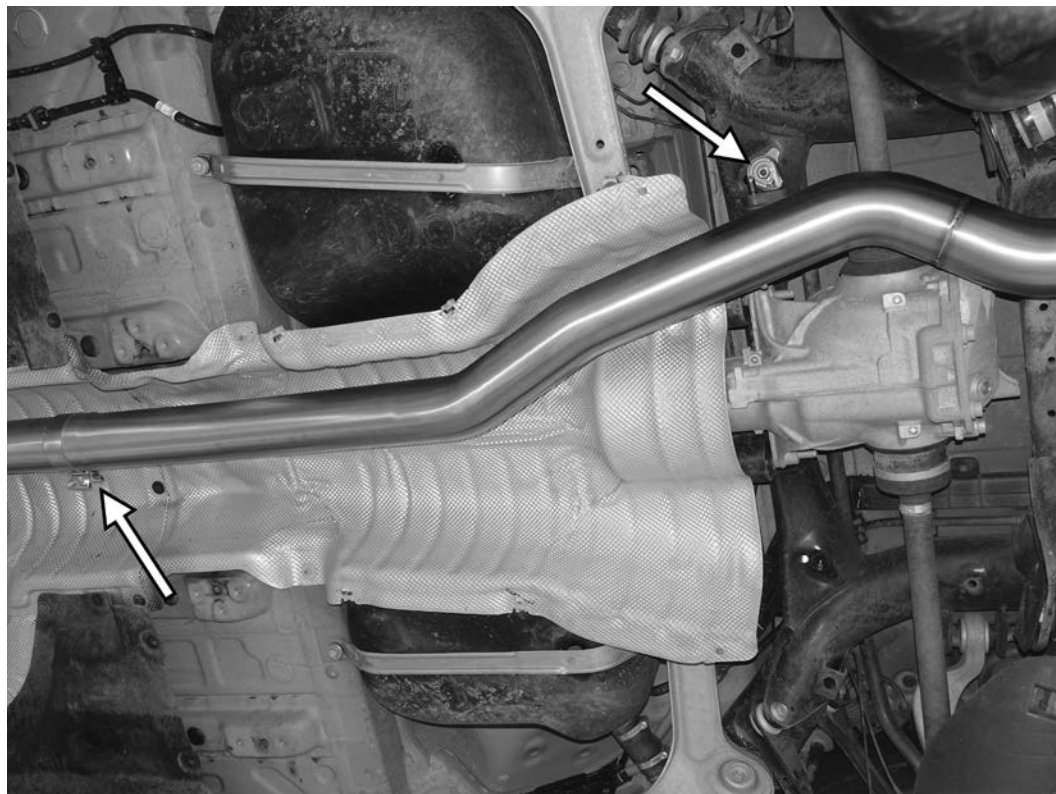

**D660-0099**

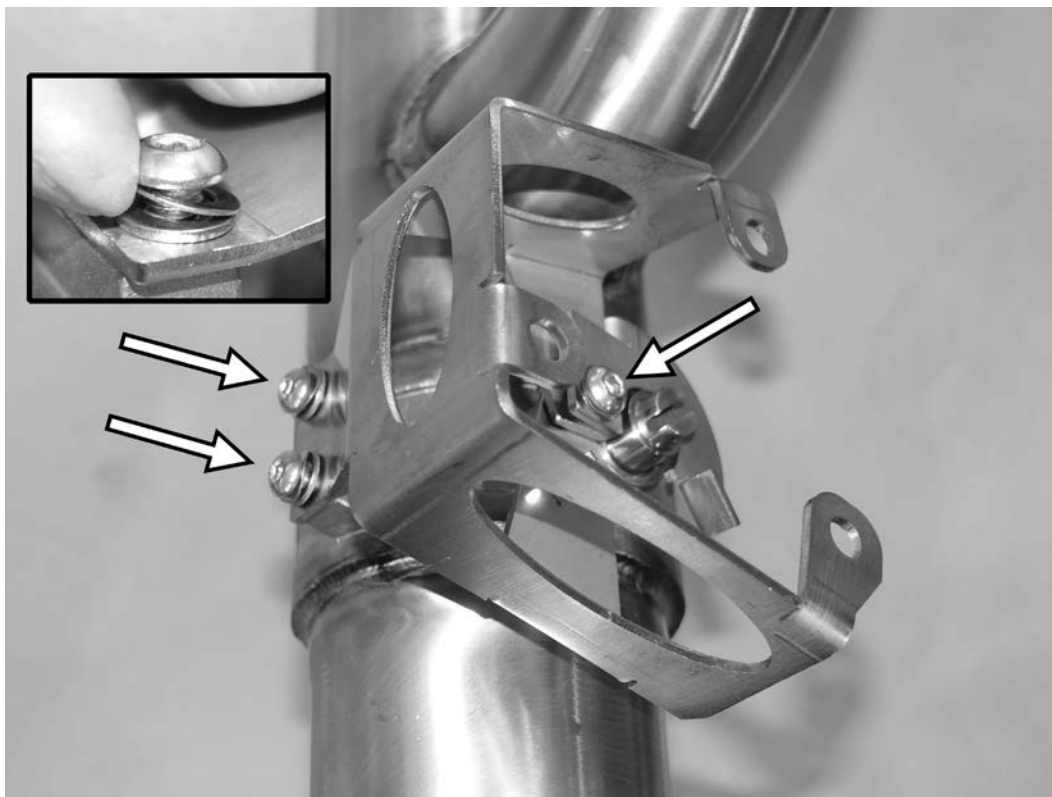

17) Install the bracket to the Dinan exhaust valve with the three 4mm allen screws, three flat washers, three spring washers, and three flat washers. The flat washer will be closest to the bracket, then the spring washer, then the screw. Tighten the 4mm allen screws to 14Nm (10 ft-lbs).

18) Swap the factory rubber hanger assemblies over from the stock rear muffler to the Dinan rear muffler.

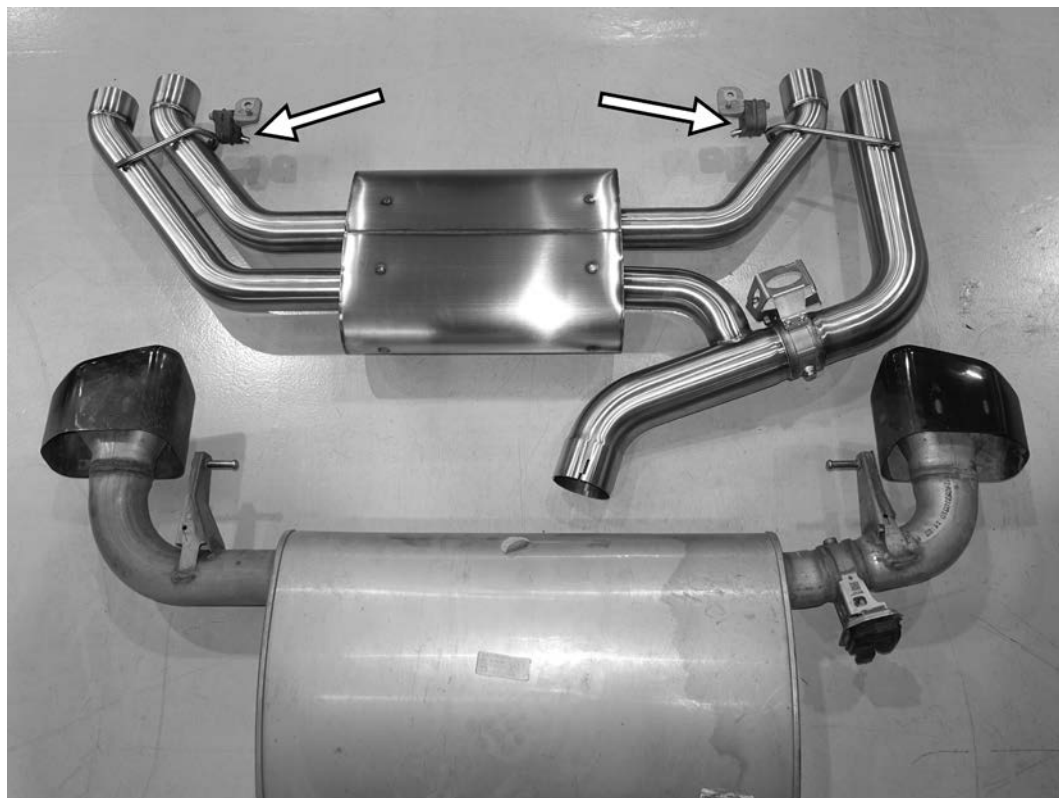

**D660-0099**

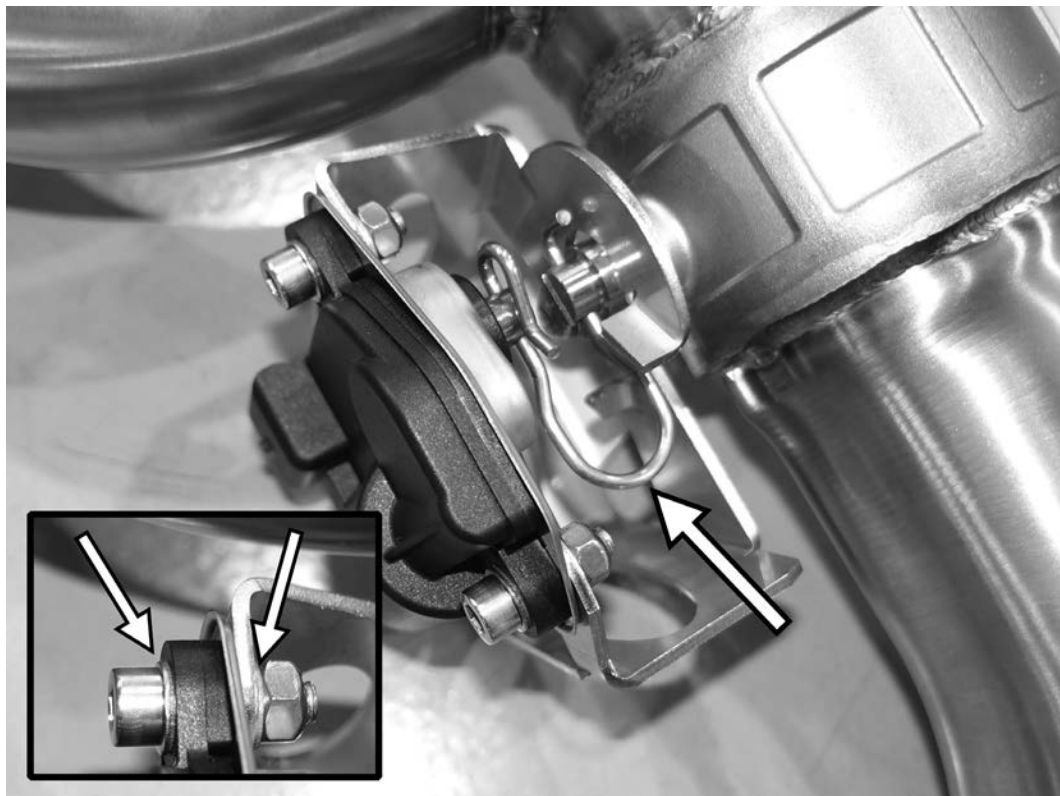

19) For pre-facelift cars (2018-19), reuse your factory exhaust valve motor. For post-facelift cars (2020+), use the actuator included in the Dinan exhaust. Place the exhaust valve motor with mounting base attached near the exhaust valve. Install the u-shaped clip between the slot in the motor and the slot in the valve as shown. To make assembly easier, you may use a diagnostic service tool to rotate the valve motor to the installation position. NEVER attempt to rotate the valve motor by hand! Secure the motor to the bracket with the three 5mm allen screws, six flat washers, and three 10mm nuts. A flat washer goes on both sides of the motor assembly.

20) In order to run the quad tip exhaust, you will need to clearance the right heat shield near where the outer exhaust tip routes (darkened in the photo). It may be necessary to temporarily mount the Dinan rear muffler assembly to see where this is. Use a small hammer to manipulate the heat shield. There should be about 6-8mm of clearance between the exhaust and the exhaust pipe. This step is only needed on the right side of the car.

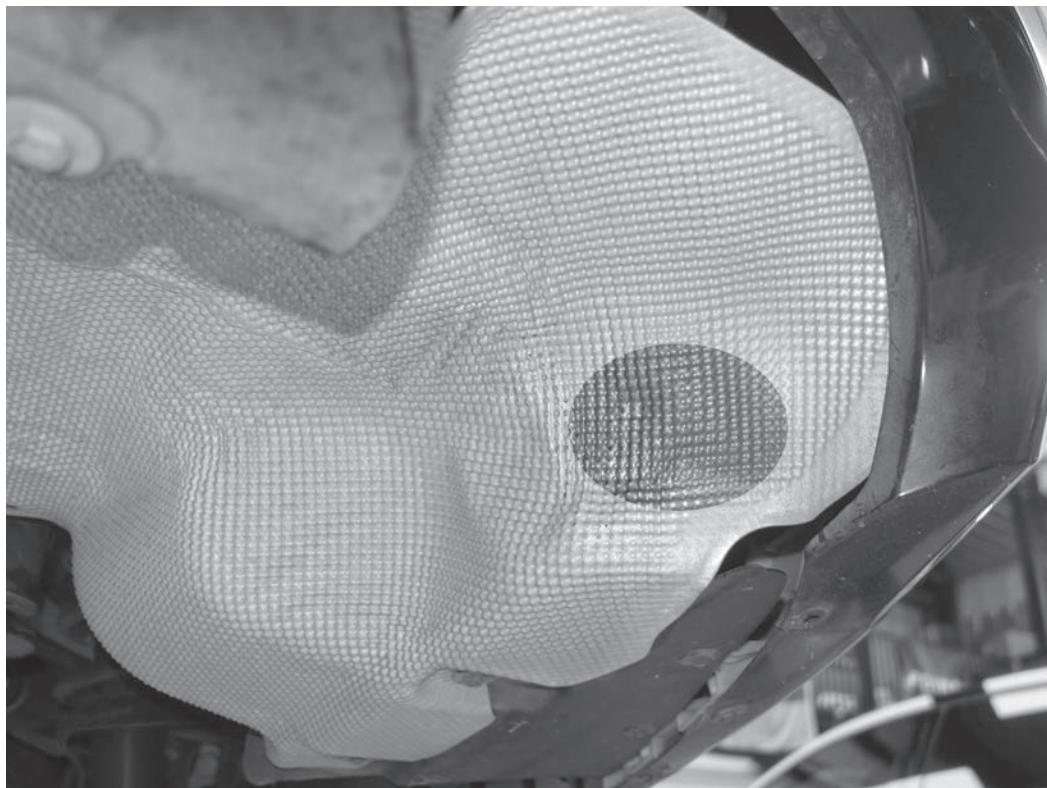



21) Install the rear muffler with the second of the two bigger clamps and the two 13mm nuts that held the factory rear exhaust hangers in place. The system should not be fully tightened yet, but should be secure enough to stay in the same location.

22) Reconnect the electrical connector to the exhaust valve motor. Make sure the harness is not twisted on itself, and that it does not rest on the exhaust system.



**D660-0099**

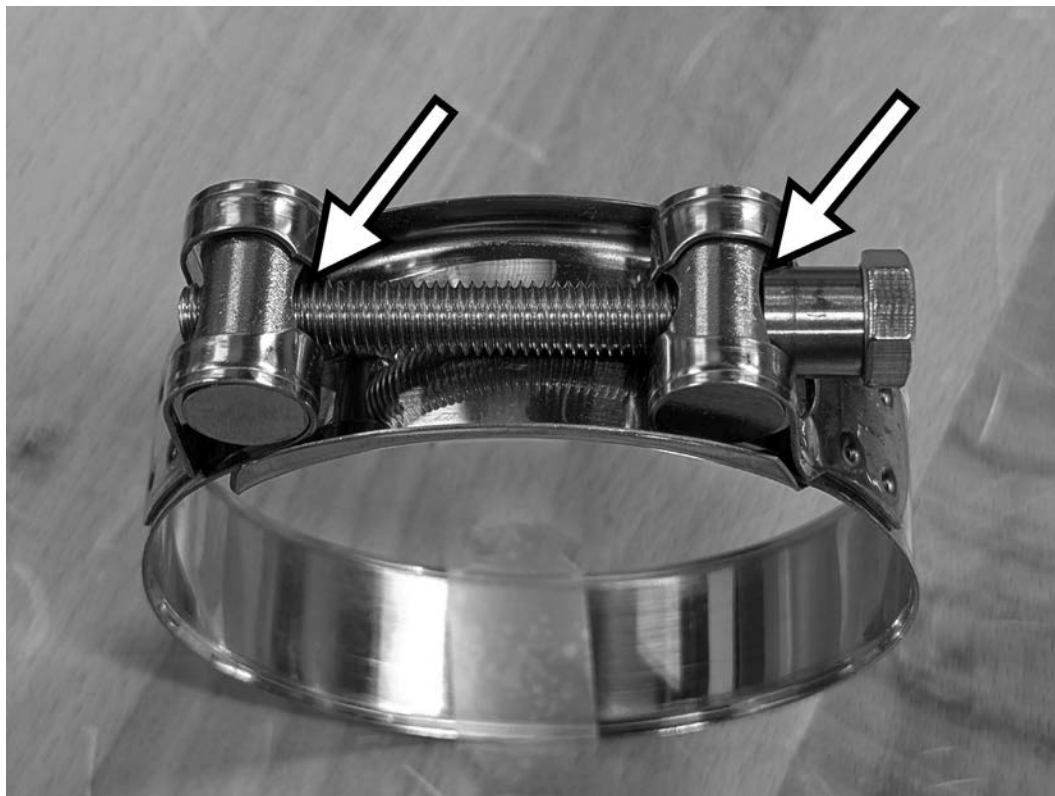

23) To allow for smoother tightening, On all four exhaust tip clamps install a little anti-sieze on the threaded rod of the clamp where the rod passes run through the barrels of the clamp.

24) The outer left exhaust pipe is a larger diameter than the other three. Find the one Dinan exhaust tip that has a slightly larger inlet and install it on the larger exhaust pipe with the one larger exhaust tip clamp. Tighten the tip somewhat, but leave loose enough to be manipulated.



**D660-0099**



25) Install the three remaining smaller exhaust tips on the other outlets of the Dinan rear muffler. Tighten the tips somewhat, but leave them loose enough to be manipulated.

26) For reference, the outer Dinan tips should begin at the top of the Dinan letters of the inner tip. This is not a final adjustment, so do not tighten the clamps on the tips yet.

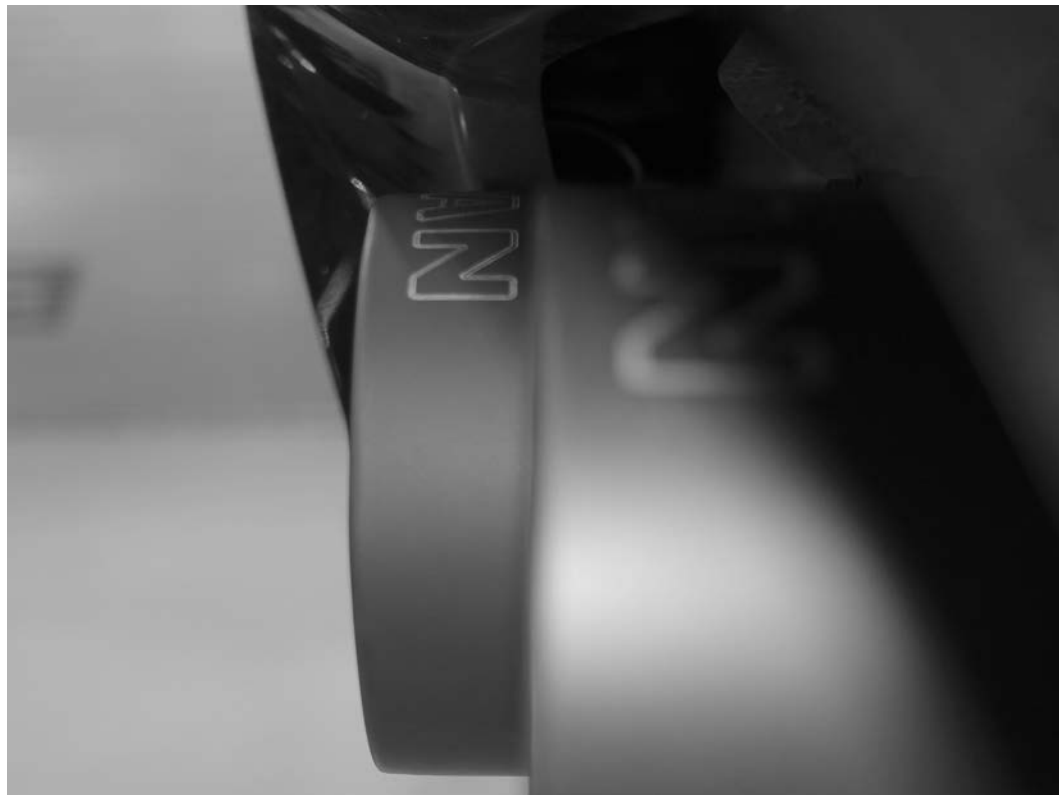

**D660-0099**

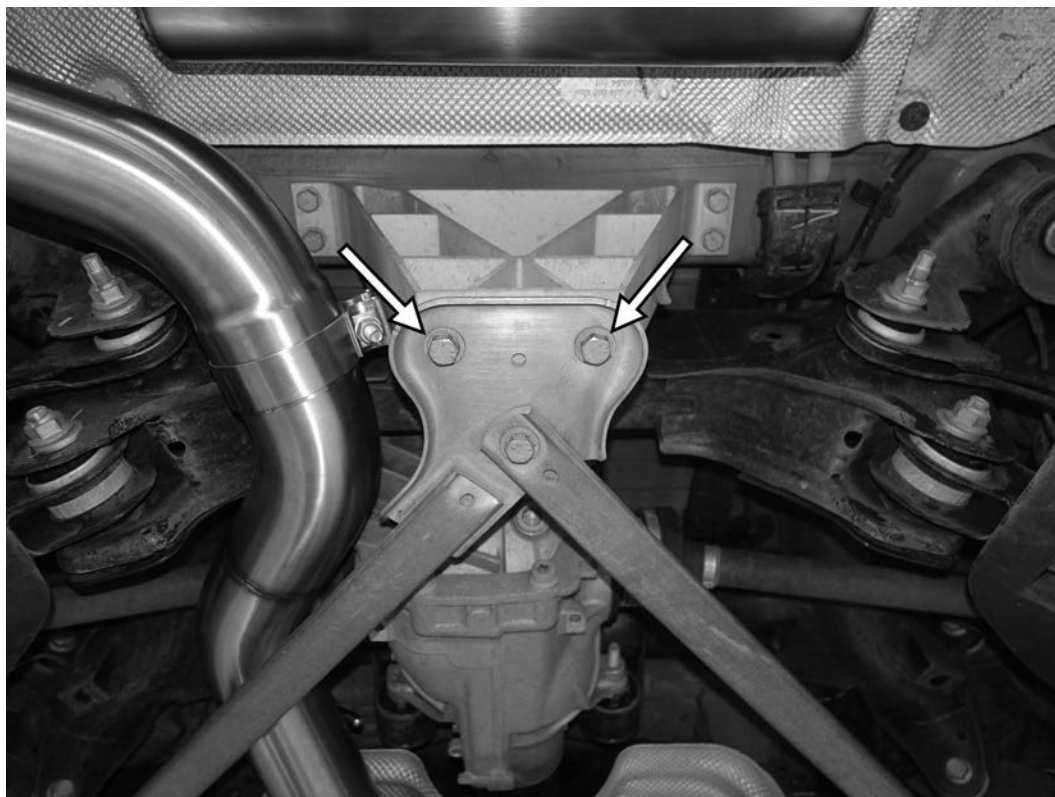

27) Install the chassis stiffening brace to the verticle brace behind the rear subframe with the the two 13mm screws.

28) Install the two 13mm screws from the front side of the chassis stiffening brace, and then install the one 13mm nut from the middle bracket on the braces. Repeat these steps on the right side side of the car. Tighten the six 13mm screws on the chassis stiffening brace to 100Nm (74 ft-lbs). Then tighten the screws an additional 90°. Tighten the two 13mm nuts on the brace to 28Nm (21 ft-lbs). BMW recommends replacing these screws and nuts every time they are used.



**D660-0099**

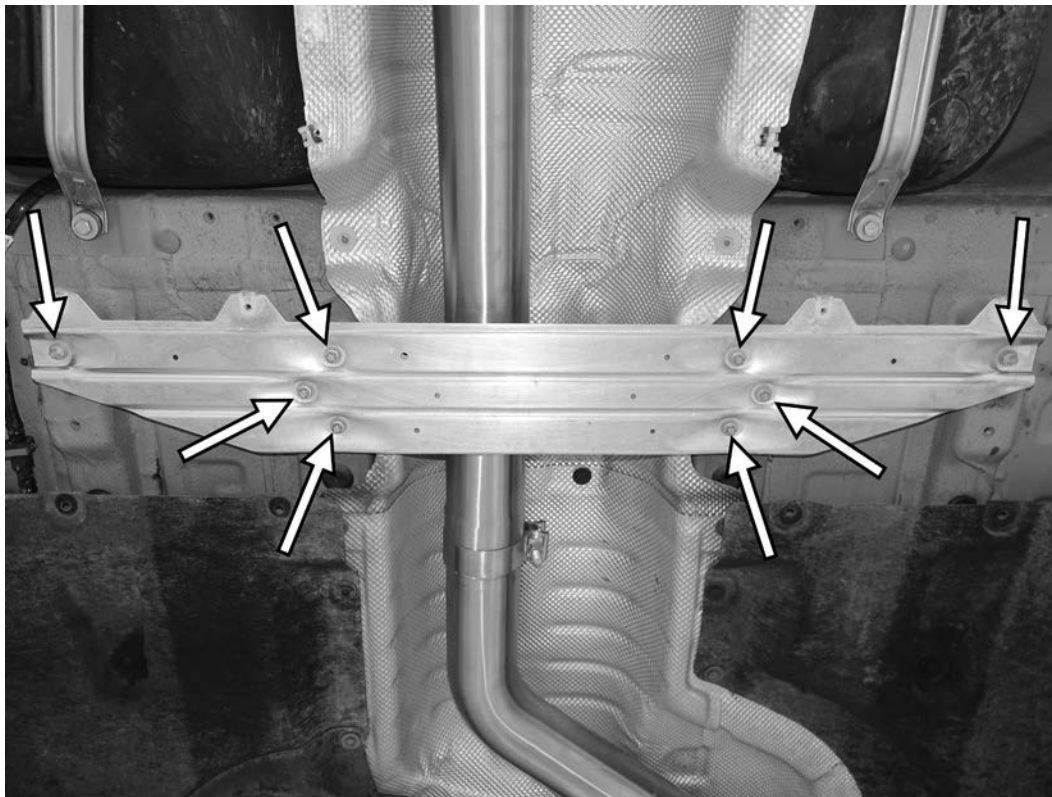

29) Reinstall the crossbrace to the center of the car with ten E10 external torx screws. Tighten the screws to 20Nm (15 ft-lbs).

30) Working from the front of the car to the back, tighten the 13mm nut on the front exhaust hanger to 19Nm (14 ft-lbs). Then, tighten the front clamp to the downpipe to 45Nm (33 ft-lbs).

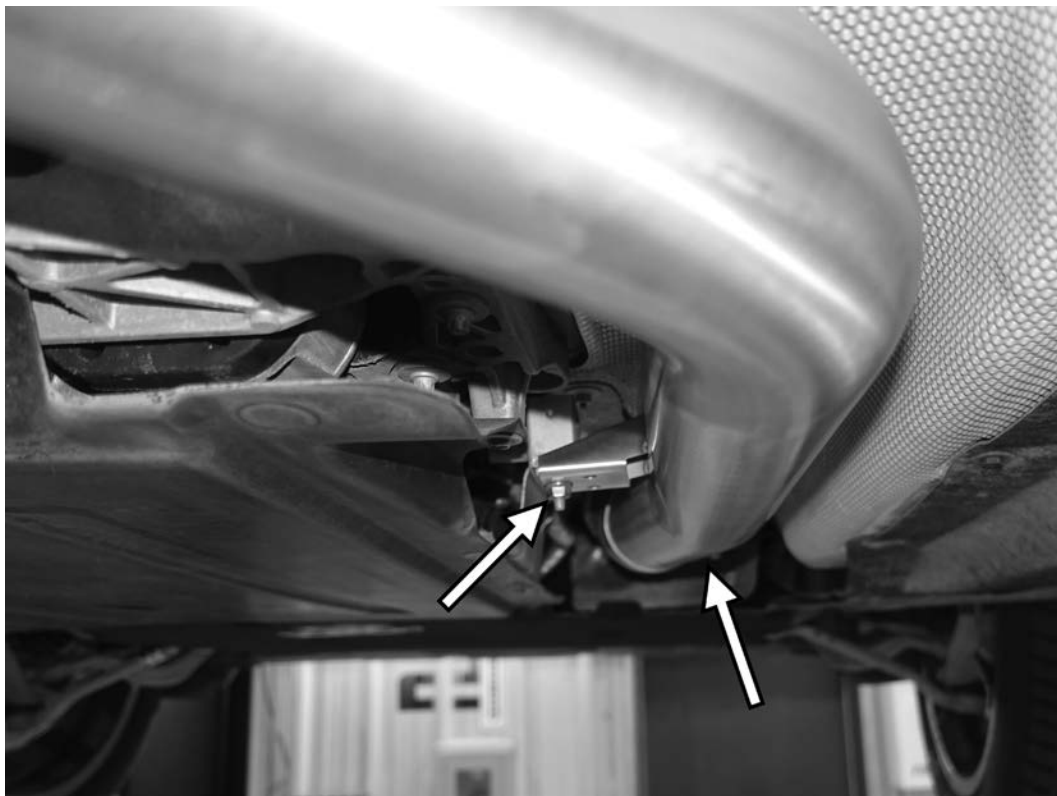

**D660-0099**

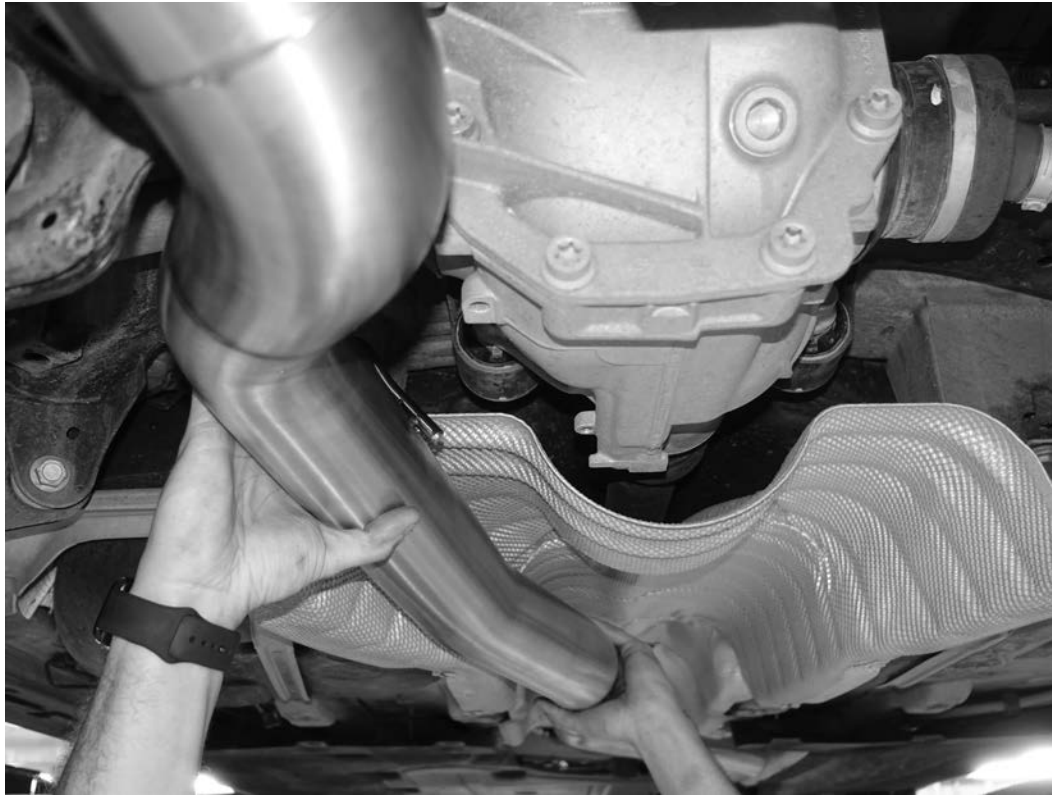

31) Adjust the midsection of the exhaust by rotating it. Make sure there is plenty of clearance between the exhaust and the crossbrace, as well as the chassis stiffening brace. Note how moving the midsection also changes the location of the rear muffler and exhaust tips. Tighten the 13mm nut on the factory hanger to the midsection to 19Nm (14 ft-lbs). Once adjusted, tighten the clamp on the front of the midsection to 45 Nm (33 ft-lbs). Then tighten the clamp on the back of the midsection to 45Nm (33 ft-lbs).

32) Once adjusted, fully tighten the two 13mm nuts on the rear factory hangers on the back of the Dinan rear muffler. Tighten the nuts to 19Nm (14 ft-lbs). BMW recommends replacing these nuts every time they are used.



**D660-0099**

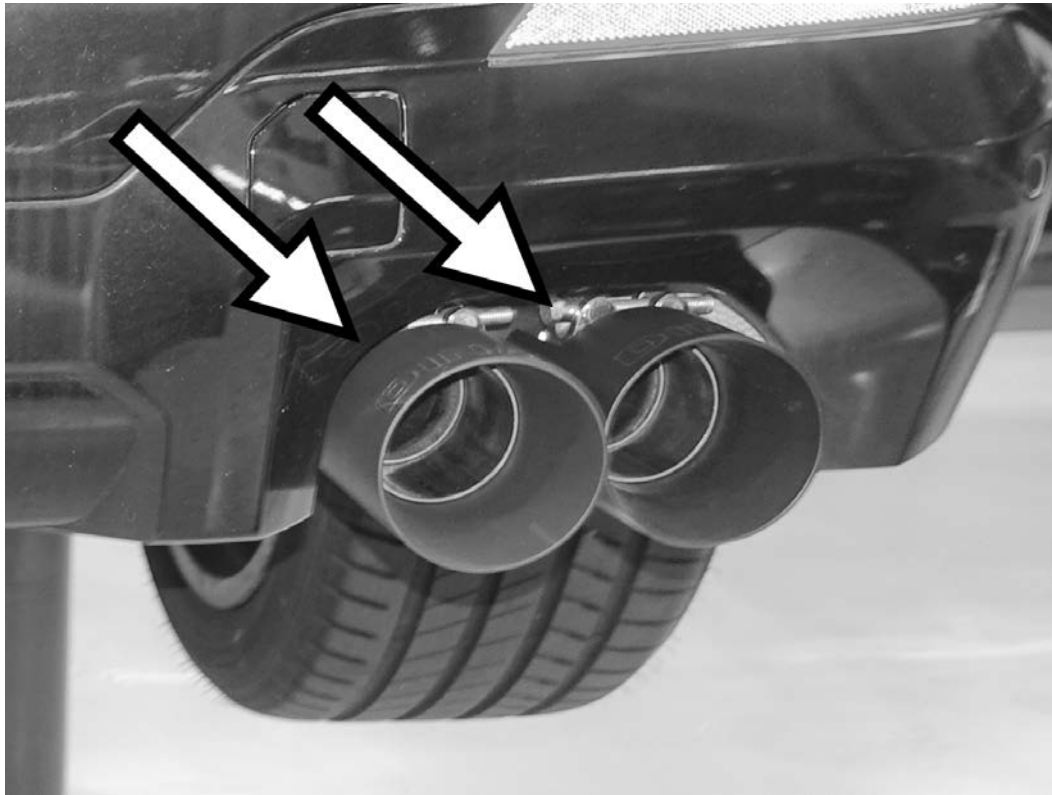

33) Finalize the position of the exhaust tips, and then tighten the 13mm nuts on all four exhaust tip clamps.

34) Reinstall the panel that goes between the bottom of the rear bumper and the exhaust heat shield. Secure the panel with the ten 10mm screws, and tighten the screws to 2.6Nm (23 in-lbs).

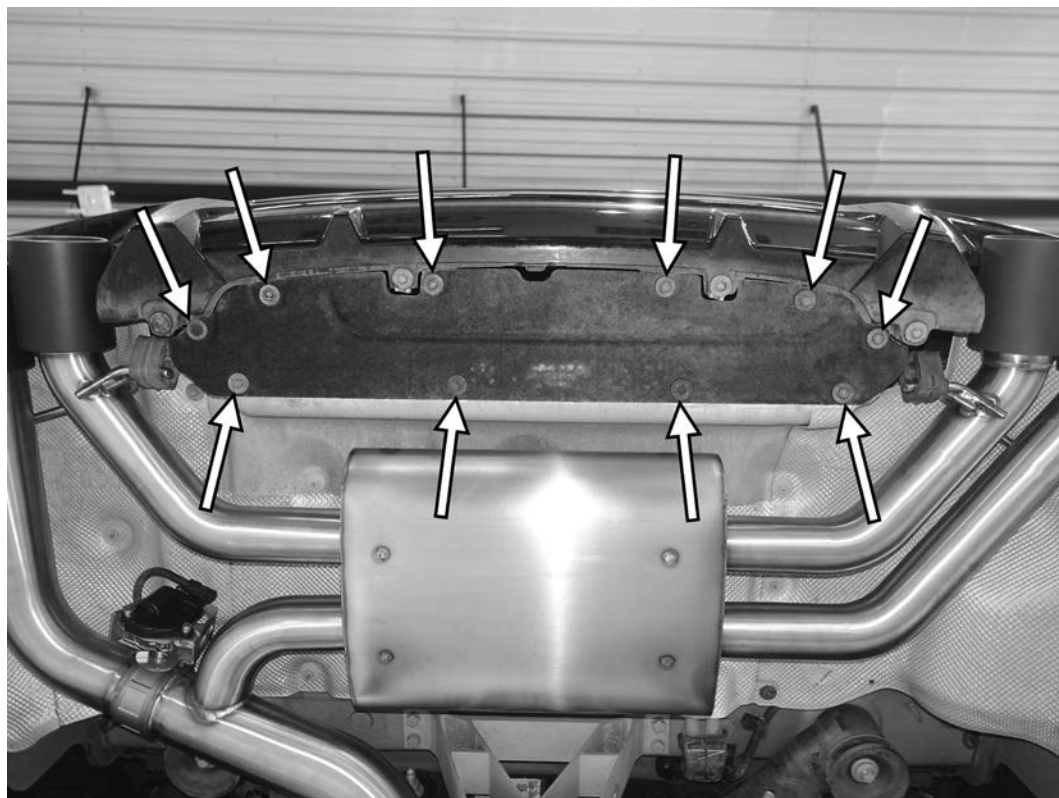

**D660-0099**

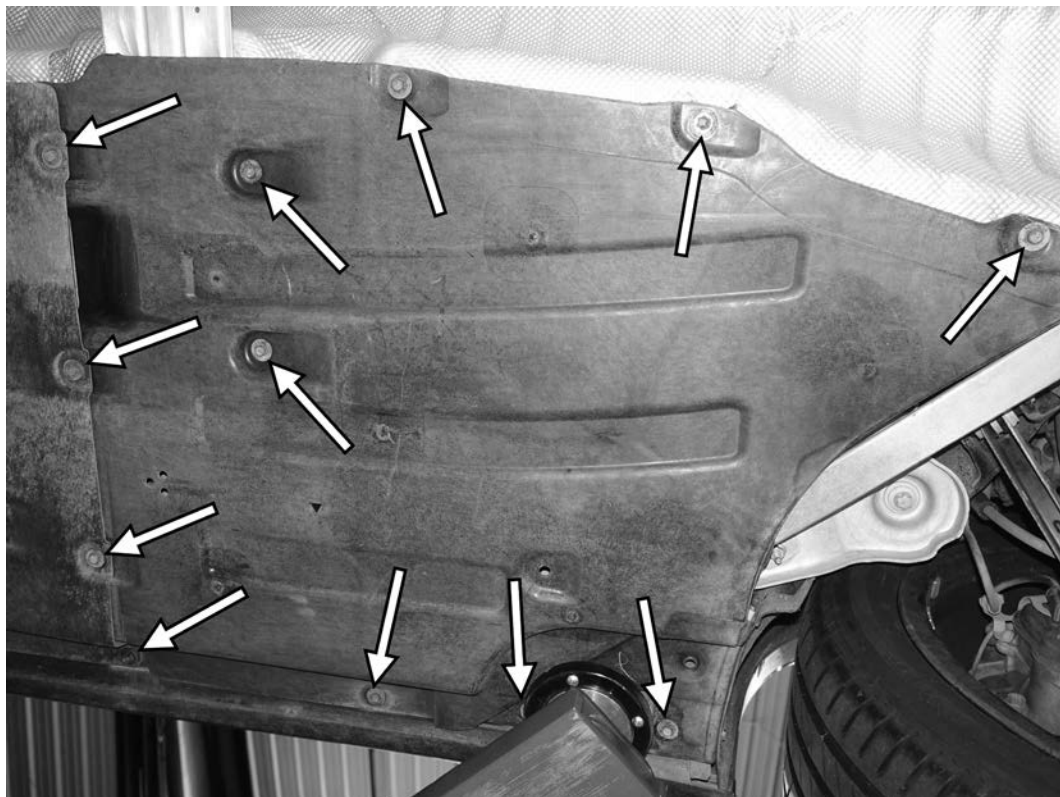

35) Reinstall the right rear underbody panel, making sure it interacts with the panel in front of it as it did stock. Install the twelve 10mm fasteners holding the panel on to 2.6Nm (23 in-lbs). Repeat this process on the other side of the car.

36) Reinstall the two 10mm screws holding the underbody panel and the wheel well liner together. Tighten these to 2.6Nm (23 in-lbs). Repeat this process on the other side of the car.



**D660-0099**





**D660-0099**

**dinancars.com**