

Fuel Pressure Regulator DWR1000c (6-1002-FRB, 6-1002-FRT)



The *DWR1000c* compact regulator is engineered to support EFI engines producing between 250HP and 2000HP. This regulator features the optimum balance of fitment versatility, premium construction, and precision performance. It is available in your choice of black or titanium finish.

- Precision performance and versatility of up to 1,000lph
- Supports up to 2000hp on Ethanol
- Supports up to 2500hp on Gasoline
- -6AN ORB inlets, -6AN ORB outlet
- Compatible with all fuels including methanol and ethanol
- 2 psi per turn precision ball bearing adjustment
- 3 Year Comprehensive Warranty

Dimensions

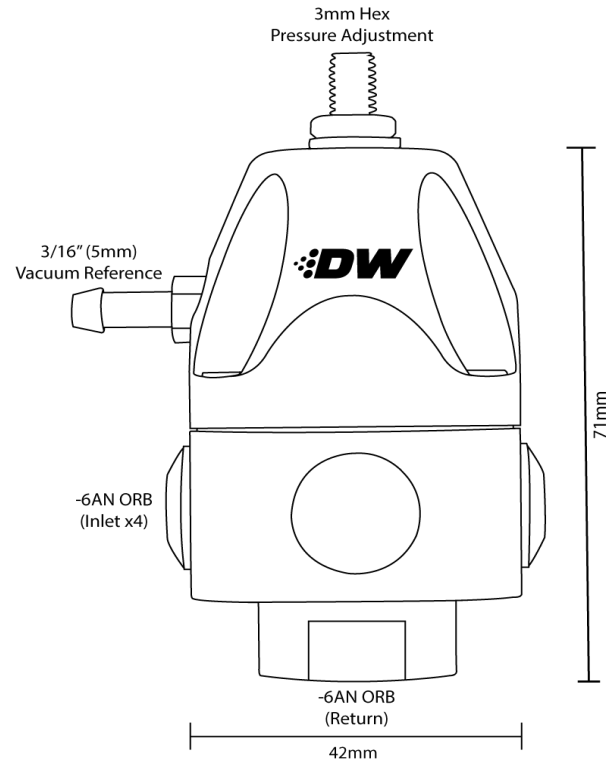

Specifications

Weight	6.9 oz (196 g)
External Materials	Anodized T6061
Hardware/Brackets	300 Stainless Steel
Tension Spring	Stainless Spring Steel
Diaphragm	35mm Fiber-Viton
Pressure Range	30-120psi
Flow Rating	1000 LPH
HP Rating	2000 HP
Gauge Port Fitting	1/8" NPT
Inlet Ports	Quad -6AN ORB (Sides)
Outlet Ports	Single -6AN ORB (Bottom)
Vac/Boost Ref. Port	1/16" NPT
Vac/Boost Ref Barb	3/16"

THIS PRODUCT MAY BE USED SOLELY ON VEHICLES USED IN SANCTIONED COMPETITION WHICH MAY NEVER BE USED UPON A PUBLIC ROAD OR HIGHWAY, UNLESS PERMITTED BY SPECIFIC REGULATORY EXEMPTION