

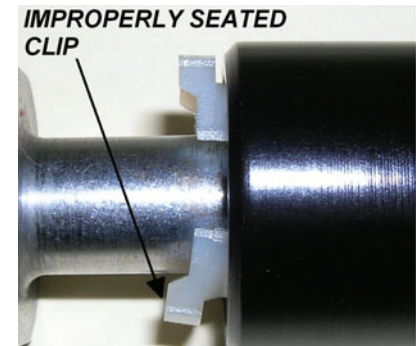

**Russell EFI Fitting**  
**Part #640850, 640853, 640860, 640863 & 640730**  
**INSTALLATION INSTRUCTIONS**

Please study this procedure carefully before assembling your new Russell EFI Fitting. If you have any questions, please call our **Technical Hotline at: 1-800-416-8628**, 7:00 am - 5:00 pm, Pacific Standard Time, Monday through Friday.

1. Clean and inspect the mating male SAE quick-disconnect tube for damage such as burrs, nicks, and other features that can be detrimental for a proper seal. Repair or replace any damaged components before continuing with the install. Remove and install the included Russell quick-disconnect fitting clip onto the male SAE quick-disconnect tube with the inner prongs of the clip securely installed onto the lip of the male tube.
2. Lightly lubricate the male tube where the o-ring seals of the Russell fitting will make contact. Slide the Russell EFI quick-disconnect fitting onto the male SAE quick-disconnect tube until the outer prongs of the Russell quick-disconnect fitting clip are engaged onto the Russell fitting body. Ensure that the Russell quick disconnect fitting clip is properly engaging the Russell fitting body by pulling on the connection and inspecting the clip.
3. Pressure test the connection prior to operation.

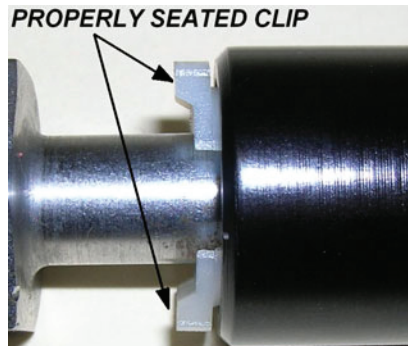
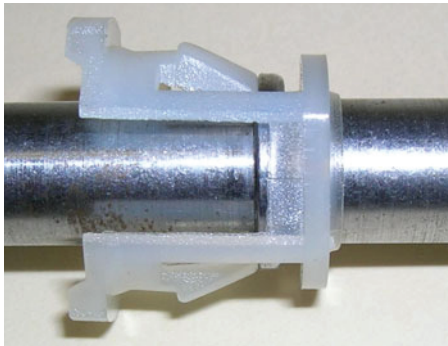

©2011 Edelbrock LLC  
Rev. 4/11 - AJ/mc

**Edelbrock LLC, 2700 California Street, Torrance, CA 90503**  
**Toll-Free Tech Line: 1-800-416-8628, Sales/Office Line: 310-781-2222**

Part #640850  
Brochure #63-640850



**Russell EFI Fitting**  
**Part #640850, 640853, 640860, 640863 & 640730**  
**INSTALLATION INSTRUCTIONS**

Please study this procedure carefully before assembling your new Russell EFI Fitting. If you have any questions, please call our **Technical Hotline at: 1-800-416-8628**, 7:00 am - 5:00 pm, Pacific Standard Time, Monday through Friday.

1. Clean and inspect the mating male SAE quick-disconnect tube for damage such as burrs, nicks, and other features that can be detrimental for a proper seal. Repair or replace any damaged components before continuing with the install. Remove and install the included Russell quick-disconnect fitting clip onto the male SAE quick-disconnect tube with the inner prongs of the clip securely installed onto the lip of the male tube.
2. Lightly lubricate the male tube where the o-ring seals of the Russell fitting will make contact. Slide the Russell EFI quick-disconnect fitting onto the male SAE quick-disconnect tube until the outer prongs of the Russell quick-disconnect fitting clip are engaged onto the Russell fitting body. Ensure that the Russell quick disconnect fitting clip is properly engaging the Russell fitting body by pulling on the connection and inspecting the clip.
3. Pressure test the connection prior to operation.

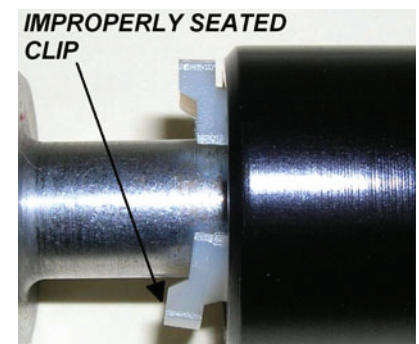
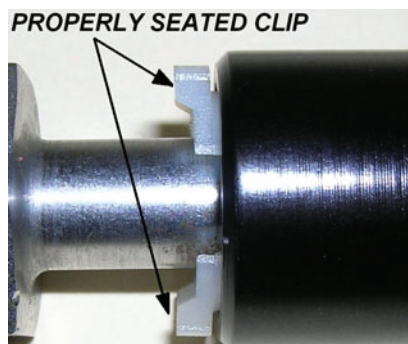
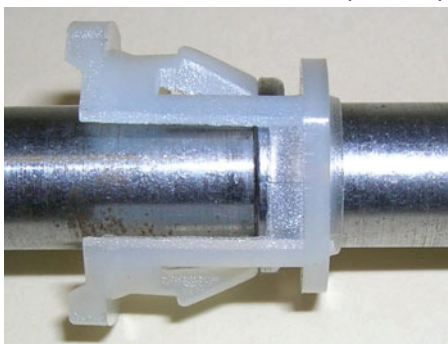

©2011 Edelbrock LLC  
Rev. 4/11 - AJ/mc

**Edelbrock LLC, 2700 California Street, Torrance, CA 90503**  
**Toll-Free Tech Line: 1-800-416-8628, Sales/Office Line: 310-781-2222**

Part #640850  
Brochure #63-640850