



INSTALLATION GUIDE: AWE EXHAUST SUITE FOR THE SUBARU WRX (VB)

For up-to-date fitment information, please visit the product page on [AWE-Tuning.com](https://www.awe-tuning.com).

THIS GUIDE IS INTENDED FOR THE FOLLOWING PART NUMBERS:

- 3015-42979 AWE Touring Edition Exhaust for VB Subaru WRX - Chrome Silver Tips
- 3015-43979 AWE Touring Edition Exhaust for VB Subaru WRX - Diamond Black Tips
- 3020-42979 AWE Track Edition Exhaust for VB Subaru WRX - Chrome Silver Tips
- 3020-43979 AWE Track Edition Exhaust for VB Subaru WRX - Diamond Black Tips
- 3015-49424 AWE Touring Edition Axleback Exhaust for VB Subaru WRX - Vapor Blue Tips
- 3015-49979 AWE Touring Edition Catback Exhaust for VB Subaru WRX - Vapor Blue Tips
- 3020-49424 AWE Track Edition Axleback Exhaust for VB Subaru WRX - Vapor Blue Tips
- 3020-49979 AWE Track Edition Catback Exhaust for VB Subaru WRX - Vapor Blue Tips

Welcome to the AWE family, and congratulations on your purchase of the AWE Exhaust for the Subaru WRX VB.

Exquisite build quality and craftsmanship, coupled with industry leading performance, distinguish this exhaust system from all others.

*For up to the minute fitment information, be sure to visit the AWE website. As always, AWE Performance Specialists are standing by for any questions, [right here](#).

PARTS LIST (SUBARU WRX VB SYSTEMS)



Inspect **ALL** parts prior to disassembly of vehicle; If damaged or **MISSING**, please contact the place of purchase immediately.

Symbol	Part Number	Description	QTY
	E96	AWE Flanged inlet section	1
	E97	AWE Resonator Section	1
	A35	AWE Axle pipe section	1
	A38	AWE Driver side track rear section	1
	A39	AWE Passenger side track rear section	1
	A36	AWE Driver side touring rear section	1
	A37	AWE Passenger side touring rear section	1
A >>	180300	AWE Band Clamp: 3"	4
B >>	3910-41010	Hardware Kit for Integrated Clamp Style Exhaust Tips	2
C >>	180010	4.00" OD x 2.50" ID, Slash Cut, Chrome Silver, AWE Tuning Logo, Integrated Clamp	4
	180011	4.00" OD x 2.50" ID, Slash Cut, Diamond Black, AWE Tuning Logo, Integrated Clamp	4
	180016	4.00" OD x 2.50" ID, Slash Cut, Vapor Blue, AWE Logo, Integrated Clamp	4

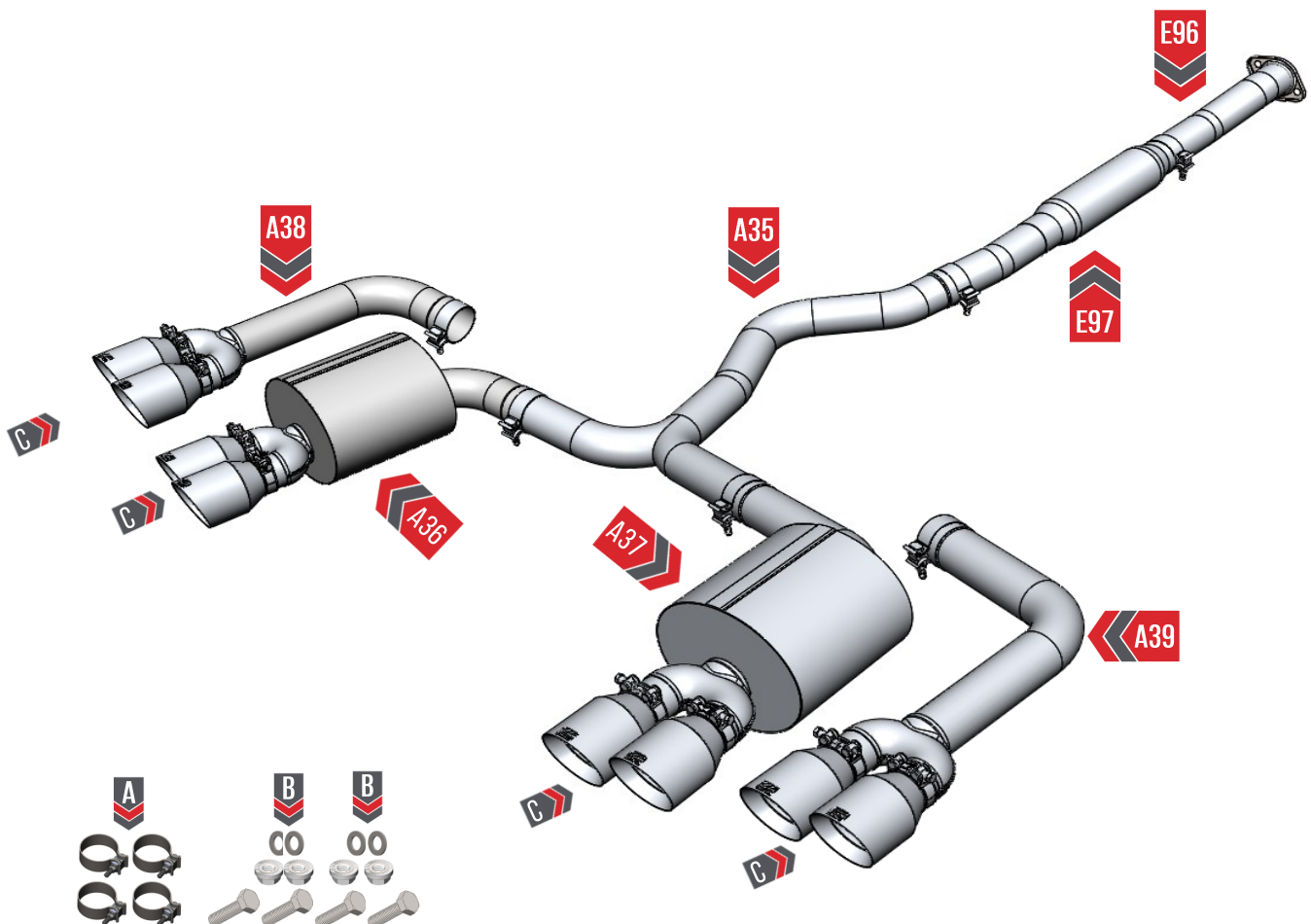



NOTE: Always refer to the manufacturer's service manual for precise torque specifications on all OEM fasteners.



CAUTION: The exhaust may be **VERY HOT** — allow adequate time for the system to cool down before disassembly. Severe burns and injury will occur if skin comes into contact with a hot exhaust system.

STEP 1



Note: Soak all bolts and rubber hangers in penetrating oil before starting any work.

Start by removing the OE dual exit exhaust by following the steps, shown in **Figure 1**.

1. To begin, you will loosen the OE flange located at **(A)**. Set the OE hardware aside as it will be re-used.
2. Remove the 5 OE rubber hangers from the exhaust shown at **(B)**.
3. With the OE exhaust no longer attached to the vehicle, remove the complete exhaust.

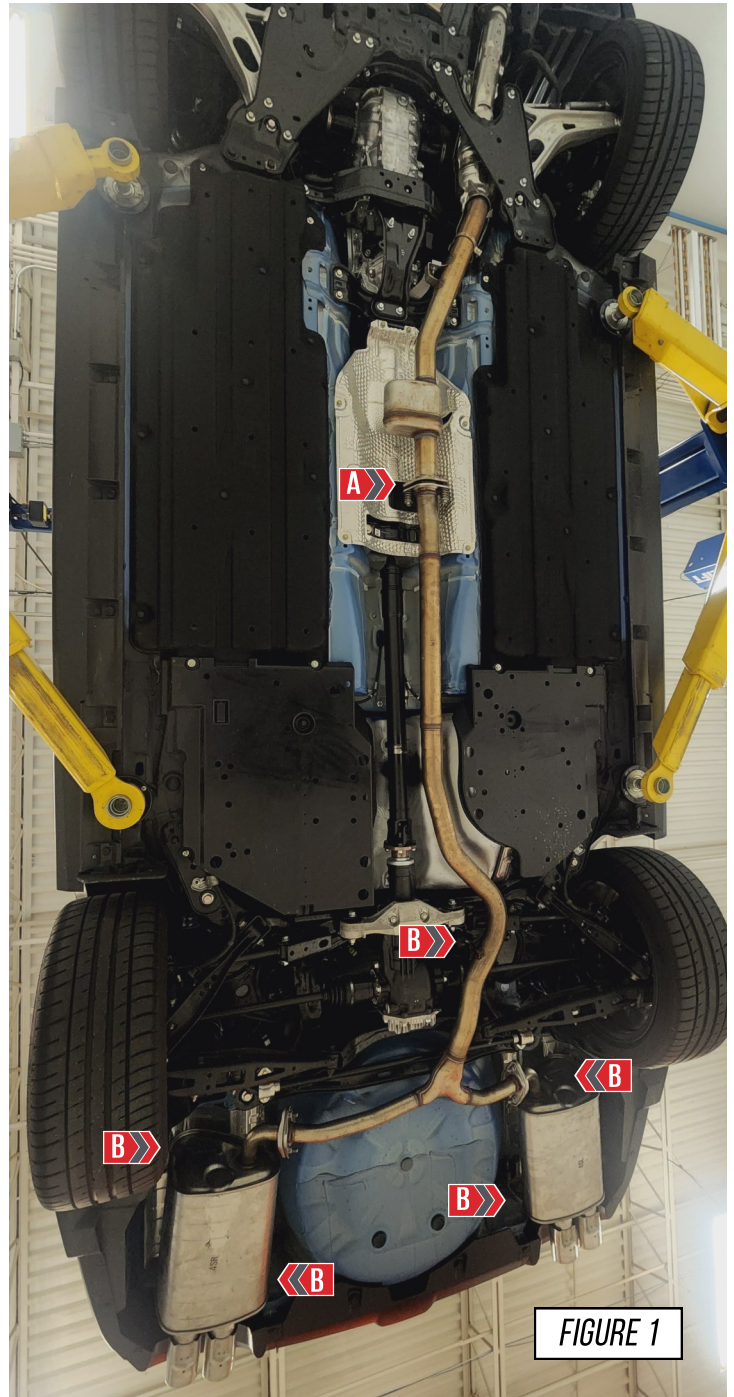
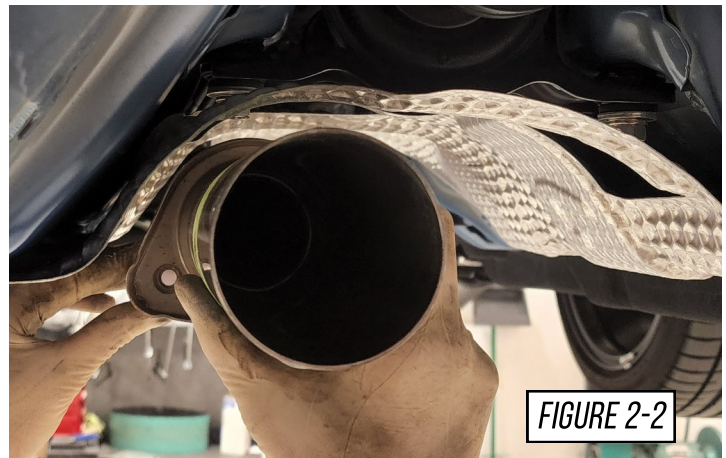

FIGURE 1

STEP 2

Using the OE gasket, install your AWE inlet section (**E96**), as shown in **Figure 2-1**. To ensure you have installed the inlet section correctly it should be angled slightly up, as shown in **Figure 2-2**
Note: Incorrect orientation of the inlet can have a negative effect on fitment as a whole.



STEP 3

Re-using the OE flange hardware tighten down the inlet section on the gasket. Tighten the bolts evenly until the shoulder is touching the flange as shown in **Figure 3**.



Note: If you do not tighten the bolts down evenly you risk damaging the gasket.

Note: Replacement flange hardware is **NOT** provided with this system.

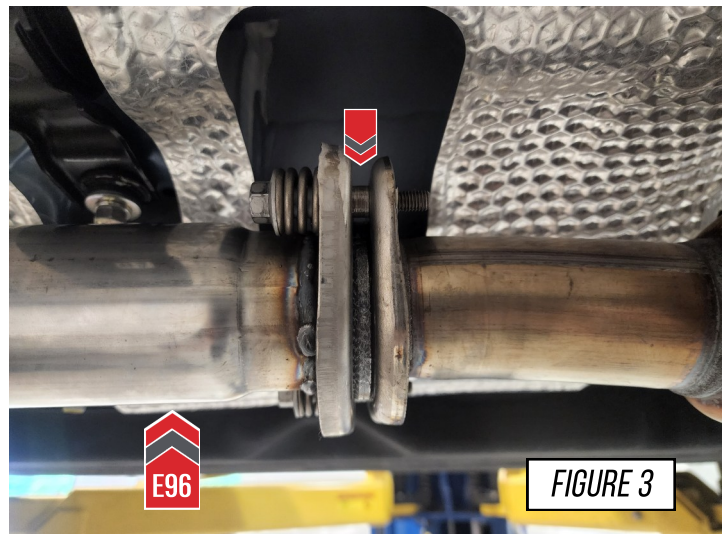

STEP 4

Using a provided clamp install your AWE resonator section (**E97**), as shown in **Figure 4**. To do this slide the clamp over the inlet section (**E96**) and bottom out the slip fit. Slide the clamp over the slip fit and snug the clamp. Do not tighten the clamp fully at this time.

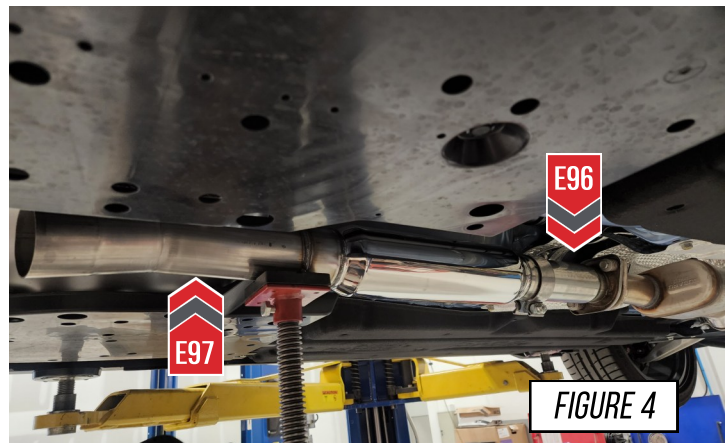

STEP 5

Install your AWE axle pipe section (**A35**), slide a clamp onto the rear side of the resonator section (**E97**). Next bottom out the axle tube on the resonator section, as shown in **Figure 5-1**. Next install the hanger bar into the OE hanger (**A**) as shown in **Figure 5-2**. Snug down the clamp over the slip fit but do not fully tighten it at this time.



FIGURE 5-1

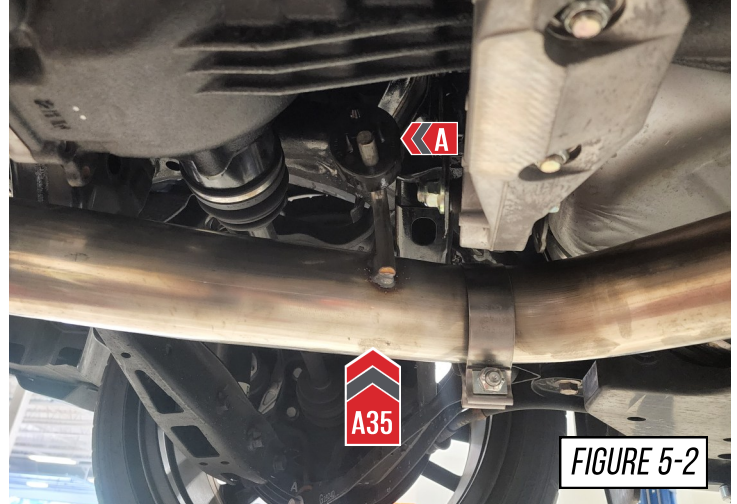

FIGURE 5-2

STEP 6

It is crucial to install each section and exhaust band clamps correctly to prevent loose joints, exhaust leaks and rattles.

Arrow A shows the expanded pipe and the preinstalled exhaust clamp being brought up to the corresponding pipe.

Arrow B shows the overlapping pipe installed correctly over the corresponding pipe.

Arrow C shows the exhaust band clamp being brought to the edge of the expanded pipe.



NOTES:

- **Do not** fully torque any exhaust clamp until the entire exhaust has been installed and adjusted.
- Torque specification is a **minimum** of 60 ft/lbs

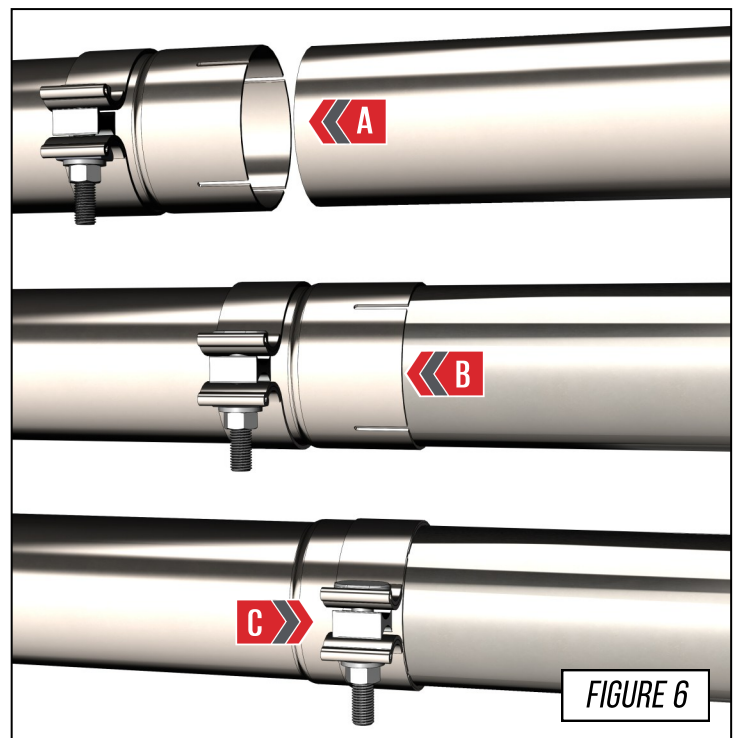
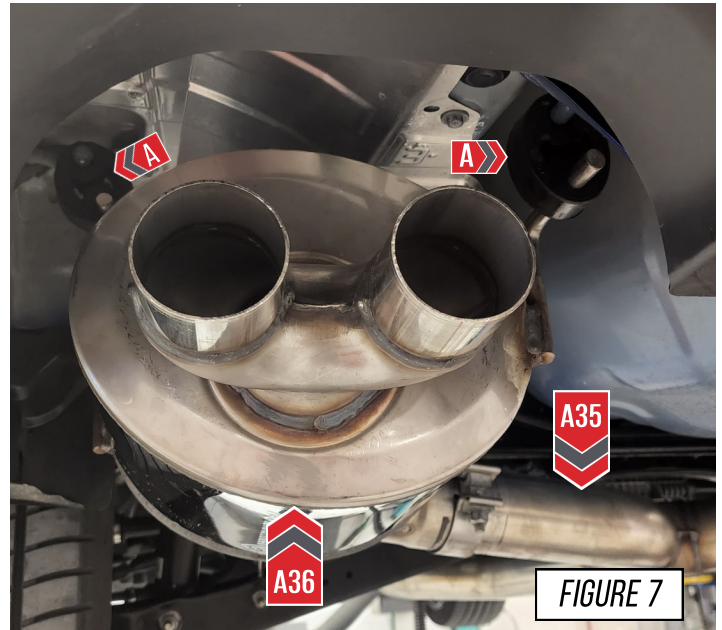

FIGURE 6

STEP 7

Install your AWE driver side rear section (**A36**) touring or (**A38**) track.

First slide the hanger bars into the OE hangers, as shown at (**A**) in **Figure 7**. Next slide a clamp over the driver side outlet of the axle tube (**A35**). Bottom out the rear section on the axle tube and snug the clamp over the slip fit. Do not fully tighten the clamp at this time.



STEP 8

Install your AWE passenger side rear section (**A37**) touring or (**A39**) track.

First slide the hanger bars into the OE hangers, as shown at (**A**) in **Figure 8**. Next slide a clamp over the passenger side outlet of the axle tube (**A35**). Bottom out the rear section on the axle tube and snug the clamp over the slip fit. Do not fully tighten the clamp at this time.

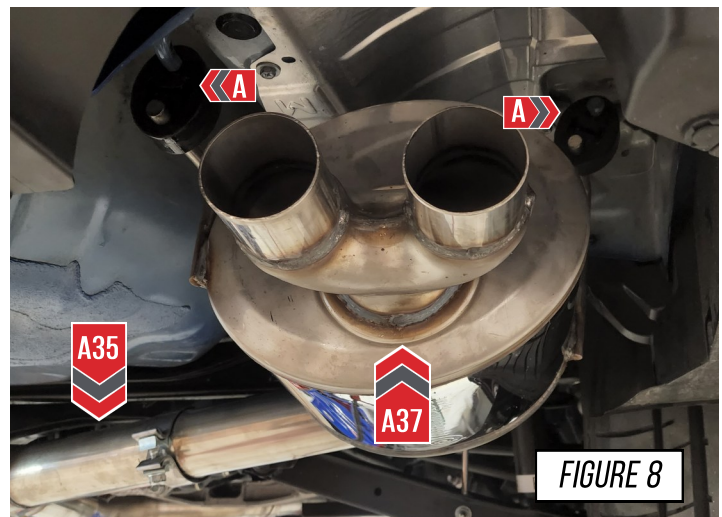

STEP 9

Gather your four AWE exhaust tips, slide them on to the tip outlet sections and orient them so the AWE logo is facing up. Using the provided integrated clamp hardware kit snug the tips down but do not fully tighten to allow for final adjustments.



STEP 10

To install the exhaust tips with integrated clamps, first, attach the exhaust tip in the proper orientation onto the exhaust outlet tube.

Insert one of the carriage bolts from the hardware kit (**3910-41010**) through the tab on the exhaust tip and thread on one of the corresponding nuts.

Using anti-seize on the bolt threads will help installation and prevent breakage of hardware.

 If exhaust system only has 2 exhaust tips while the integrated clamp kit has enough hardware for our 4 tip exhaust systems. You will have 2 sets of hardware left over that will not be used.

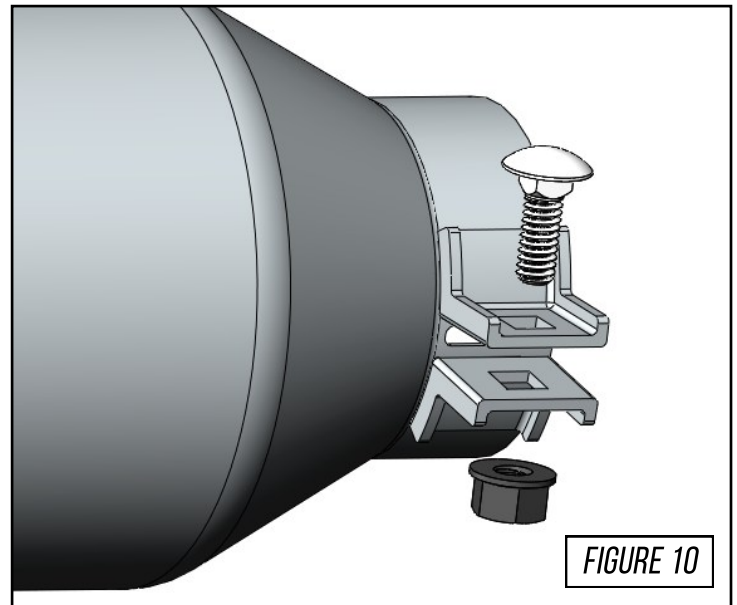

STEP 11

Make your final adjustments to the tips to ensure they are in a position you like. Once the desired positioning is achieved work from the front of the car to the back, tightening all the clamps fully and ensuring there is proper clearance of the chassis and braces.

It is now recommended to drive the car to allow the exhaust to heat cycle after all clamps and tips are fully tightened.



At this point the exhaust will be **very hot**, allow to cool before work continues.

Check the tips for correct alignment, adjust as needed.



Don't forget to see the next page for any troubleshooting needs!



FIGURE 11

ENJOY!



TROUBLESHOOTING

Issue	Solution
Exhaust is not fitting correctly	Most fitment issues are due to improperly adjusted exhaust. This includes tip fitments and rattling due to chassis contact. Check out our fitment guide for more installation tips. If your exhaust system sits too low, check and ensure that your inlet section (E96) is oriented correctly, and you may need to rotate your resonator section (E97).
Incorrect or missing parts	Double check the parts list for your system and compare them with what you received. Fill out our contact form, found below and let us know what parts you need.

CARE

Once installed properly, your AWE exhaust will provide years of trouble-free performance.

The exhaust volume and sound will settle with usage; 800-1,000 miles is required to break-in new exhaust systems.

Also, please note that the rear **180Technology®** resonator has a small drain hole to allow condensation to escape. Water drops from this area are normal.

Diamond Black and Chrome Silver Tip Care: Periodic cleaning of exhaust tips is necessary to maintain proper finish, especially in areas prone to road salt and caustic deicing solutions. Use a mild soap and water solution or car wax to clean the finish. Avoid using abrasive polishes, as they can scratch the finish.

Vapor Blue Tip Care: AWE's Vapor Blue tips must be treated with extra care, or the Vapor Blue finish will wear off prematurely. Do not use any harsh or abrasive polishes. AWE Vapor Blue tips do not come with a warranty, so polish lightly!

Any questions or comments,
please do not hesitate to contact us:

AWE
[CONTACT FORM](#)

WARRANTY

Up-to-date warranty information is found [HERE](#).