

APPLICATION
Toyota Tundra
(Non Resin Bumpers only)

MODEL YEAR
2014-2021

PART NUMBER
75309-01A

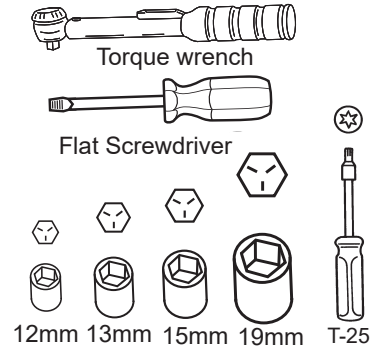
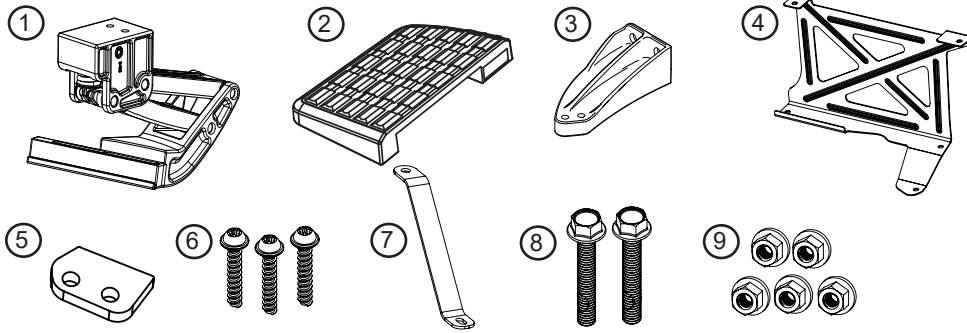

Secure linkage in vice and tighten bolts. Do not Torque. Allow steel bracket to rotate freely.

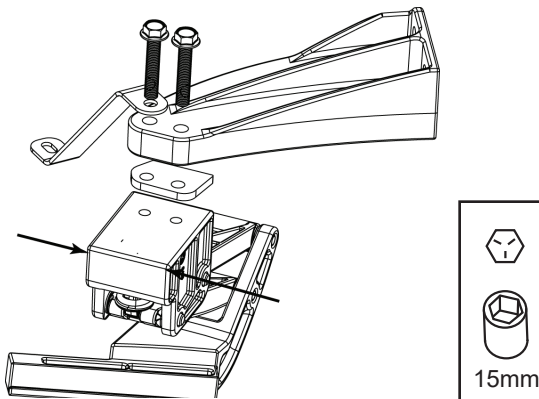

1

Remove corner bumper cap and use flat blade screwdriver to pry loose. Use caution when removing tabs.

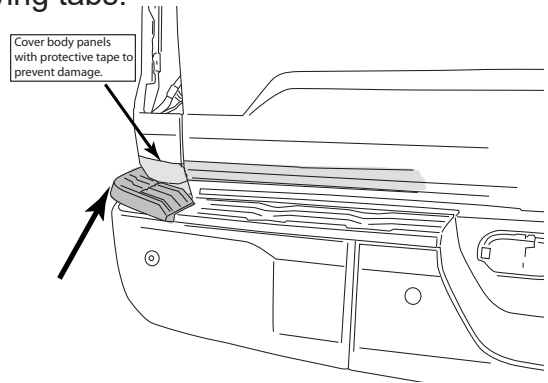

2

Remove license plate light by rotating and pulling out. Squeeze metal tabs holding trailer hitch plug and remove.

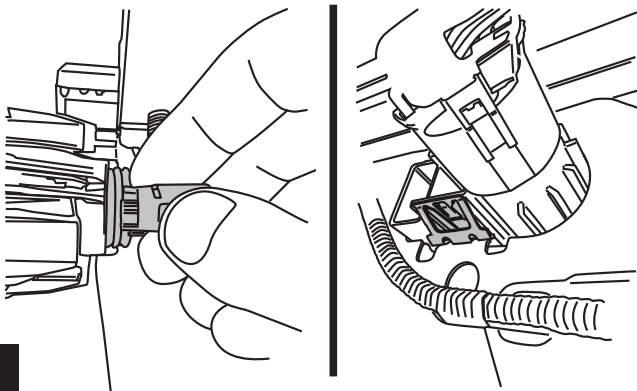

3

Remove plastic plug holding bumper cap onto lower portion of bumper. Remove license plate and plug behind holding bumper cap in place.

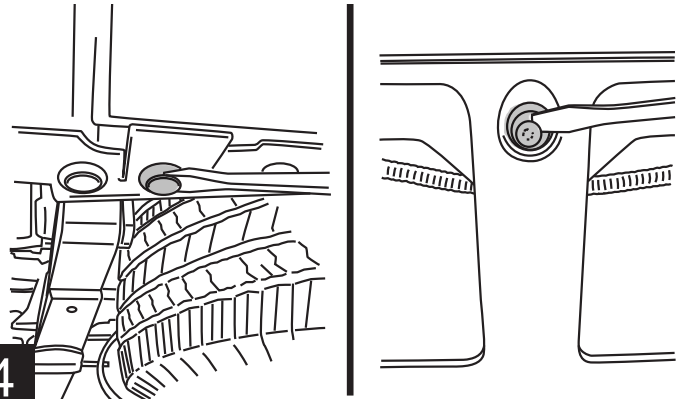

4

REALTRUCK TECH SUPPORT 1-888-983-2204 (Press 2) Monday - Friday, 7:00 AM - 5:00 PM PST

Designed and manufactured by AMP Research®. Patent Number 6,830,257; 6,641,158; 6,834,875; 6,938,909; 6,942,233; 7,007,961; 7,055,839; 7,163,221; 7,367,574; 7,380,807; 7,398,985; 7,413,204; 7,487,986. Other US and Worldwide patents pending. Made in Mexico © 2024 AMP Research
Three-year limited warranty. Professional installation is recommended.

Remove bumper cap from bumper. Use flat blade screwdriver or long pliers from underside of bumper and fold or squeeze tabs inward.

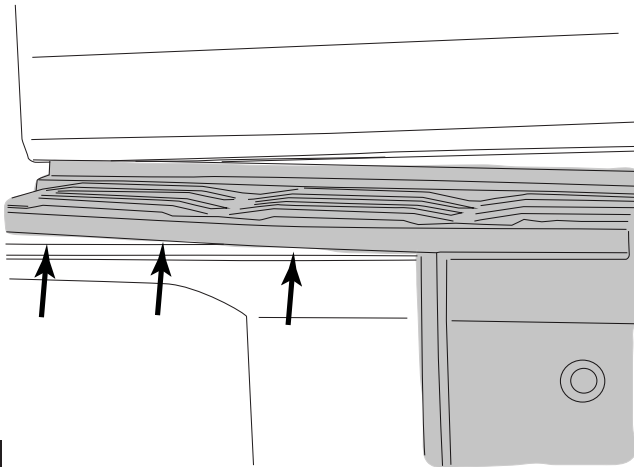

5

Loosen and remove three lower bolts that secure bumper corner bracket in place.

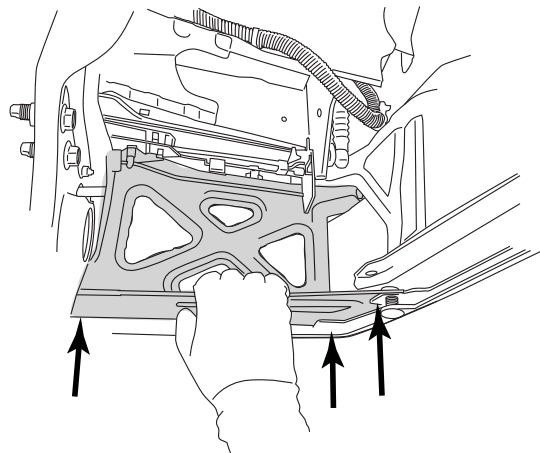

6



Lift bumper cap away and loosen and remove 2 upper bolts holding Re enforcement bracket in place.

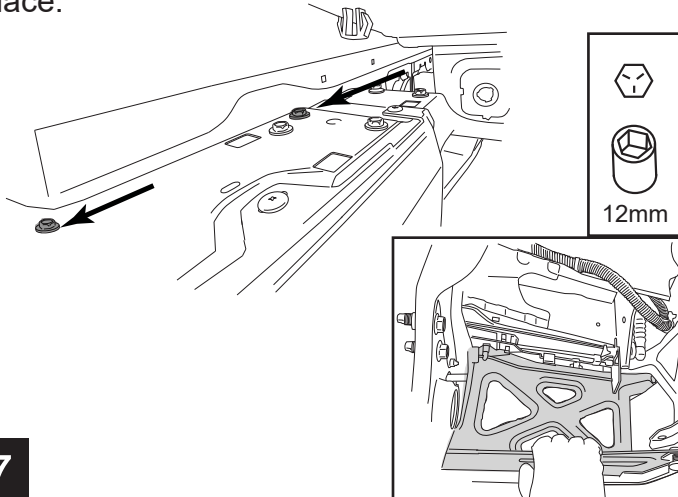

7

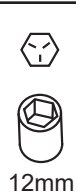

Replace Re enforcement bracket. Reinstall bolts from step 6 and 7. Use provided nuts to secure bracket in place. Replace bumper components from steps 2-5.

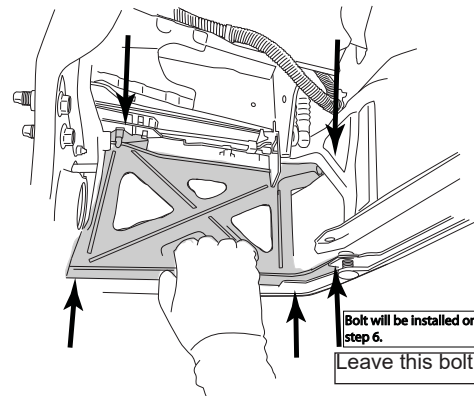

8

Bolt will be installed on step 6.
Leave this bolt out until step 10.

Driver Side bumper mount.

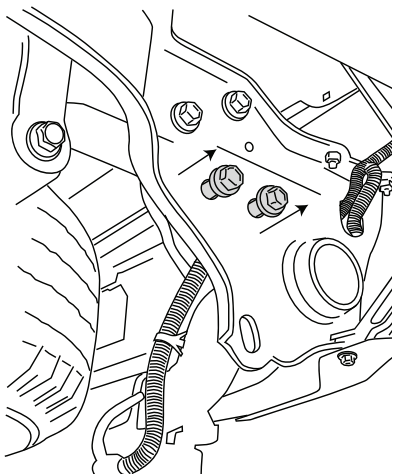

9



Install mounting bracket using factory fasteners. Torque fasteners to 90ft-lbs/125Nm. Align bumper support bracket to mounting hole in Re enforcement bracket. Torque nuts to 33ft-lbs/44Nm.

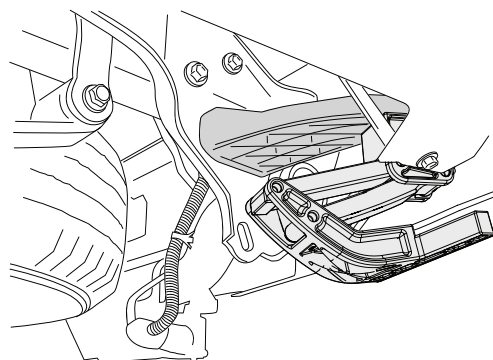

10



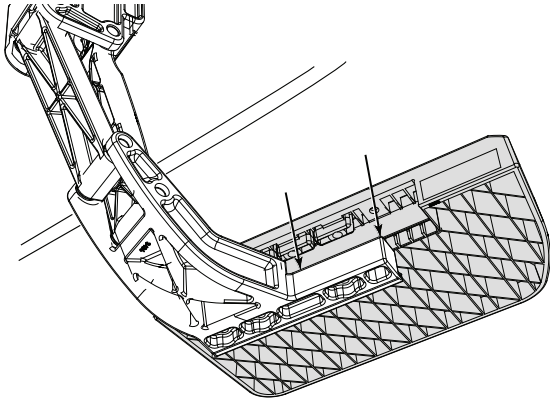

11

Insert PT Screws into corresponding holes and torque to 6 ft-lbs / 8 N.m.

NOTE: Overtightening may damage step pad.

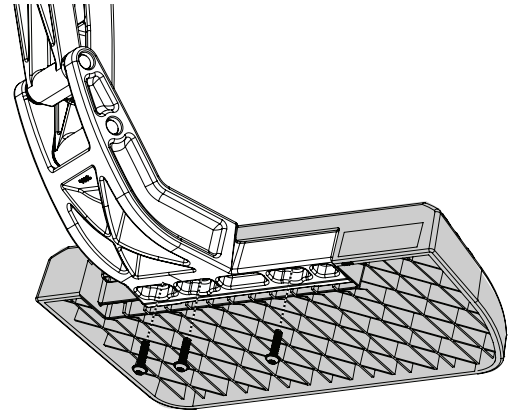

12

T-25

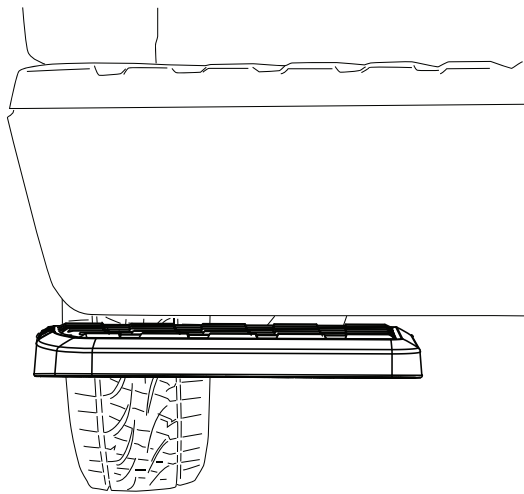

13

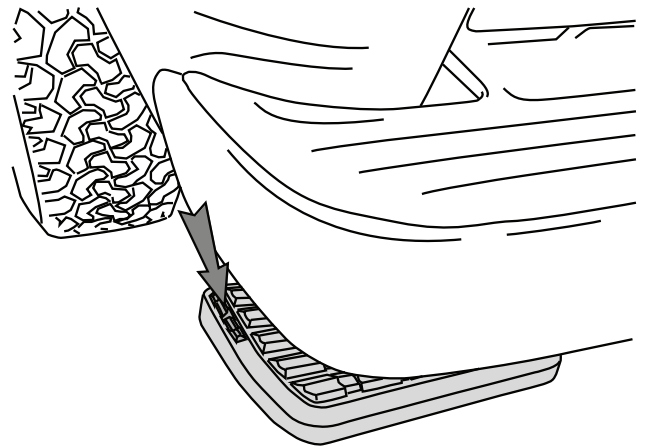

14

AMERICAN DESIGNED & ENGINEERED

Thank you for your recent Realtruck Purchase.

**REGISTER YOUR PRODUCT TODAY FOR
FASTER SERVICE & PRODUCT UPDATES**

Please visit:

www.amp-research.com/productregistration
or scan the QR Code



Product Registration Benefits:

- Ensure we have your purchase receipt and product info in our system which is required for warranty
- Faster and easier access to customer service and tech support in the unlikely event you need warranty or product support
- Registration helps us keep you up to date on product information and offers

To view other Realtruck products that may be offered for your vehicle.

Please visit: www.realtruck.com



Congratulations on the purchase of your AMP Research BedStep®

Here's what you should know...

OPERATION

- The AMP Research BedStep® is foot operated and deploys and retracts with a nudge of your foot.
- To deploy, press down using your left foot, on the forward outside corner of the step pad.
- To retract, gently kick the underside of the step pad.
- Max Load Capacity: 300lbs.
- Always use appropriate hand holds when stepping up to or down from your truck's cargo bed.

MAINTENANCE TIPS

The step pad surface and linkage arms can be washed with mild soap and water using a soft brush or sponge to dislodge any mud, dirt or accumulated road grime. Rinse with fresh water.

To prevent slipping, avoid applying waxes, lubricants or protectants like Armor All® to the step surface.

ATTENTION!

BEDSTEP SHOULD ALWAYS BE STOWED IN THE RETRACTED POSITION WHEN DRIVING.

LIMITED WARRANTY

REALTRUCK warrants product to be free from defects in material and workmanship, for terms specified below, provided there has been normal use and proper maintenance. All remedies under this warranty are limited to the repair or replacement of any item found by the factory to be defective within the time period specified.

If you have a warranty claim, first you must call our factory at the number below for instructions. You must retain proof of purchase and submit a copy with any items returned for warranty work. Upon completion of warranty work, if any, we will return the repaired or replaced item or items to you freight prepaid. Damage to our products caused by accidents, fire, vandalism, negligence, misinstallation, misuse, acts by mother nature, or by defective parts not manufactured by us, is not covered under this warranty.

THE WARRANTY TIME PERIOD IS AS FOLLOWS: THREE YEARS FROM DATE OF PURCHASE.

ANY IMPLIED WARRANTIES OF MERCHANTABILITY AND/OR FITNESS FOR A PARTICULAR PURPOSE CREATED HEREBY ARE LIMITED IN DURATION TO THE SAME DURATION AND SCOPE AS THE EXPRESS WRITTEN WARRANTY. OUR COMPANY SHALL NOT BE LIABLE FOR ANY INCIDENTAL OR CONSEQUENTIAL DAMAGE.

Some states do not allow limitations on how long an implied warranty lasts, or the exclusion or limitation of incidental or consequential damages, so the above limitations or exclusions may not apply to you. This warranty gives you specific legal rights, and you may also have other rights that vary from state to state.

FOR WARRANTY ISSUES WITH THIS PRODUCT PLEASE CALL REALTRUCK CUSTOMER SERVICE 1-888-983-2204

WARNING

Be sure to read and precisely follow the provided instructions when installing this product. Failure to do so could place the vehicle occupants in a potentially dangerous situation. After installing or reinstalling, re-check to insure that the product is properly installed.