



245 Series Twin Disc Clutch Installation Instructions

All assemblies should be balanced to the flywheel you are replacing. Twin-Disc 245 Series assemblies are not pre-balanced from the factory.

Break-in/Seat-in Procedure:

- It is very important to properly break in your clutch to ensure that the clutch will perform as advertised.
- Absolutely **NO CHASSIS DYNO** of any kind during the break-in process.
- We recommend 500 miles of normal stop and go city miles or 1200 clutch cycles, this does not mean 500 miles on the freeway.
- No full throttle spirited driving during the break-in procedure, any glazing of the friction material will greatly reduce the holding capacity of the clutch.
- No excessive slipping of the clutch during the break-in procedure.
- After the 500 mile break-in readjust your clutch (mechanical linkage).

When performance driving, all traction control devices must be turned off or clutch slippage will occur.

1) Inspect clutch assembly before disassembly. See Figure. 1. Note alignment marks.

Figure 1

2) Unbolt pressure plate by removing six nuts. **Note alignment mark (white paint) on pressure plate, floater and flywheel. These must be in same position when re-assembling components.**

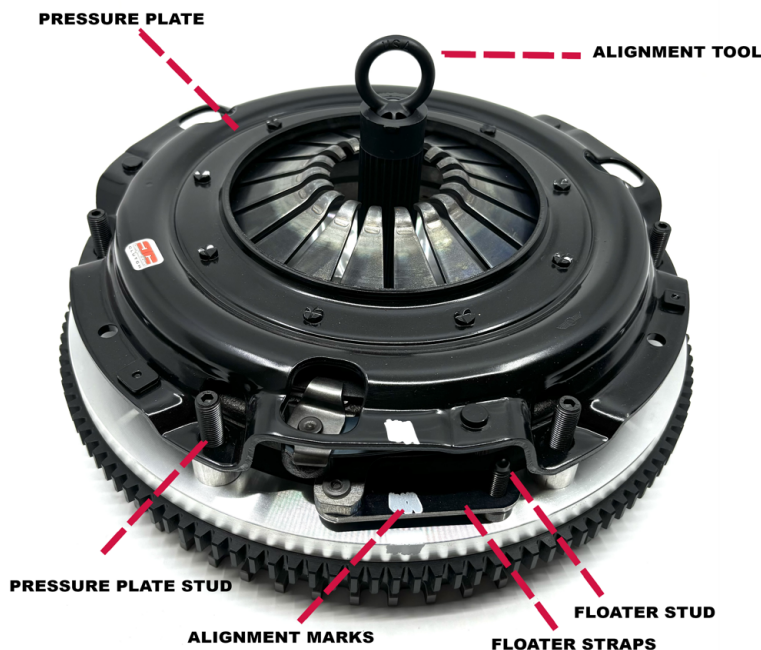

3) Remove top disc and alignment tool. Notice “Flywheel Side” on the disc center. See Figure 2

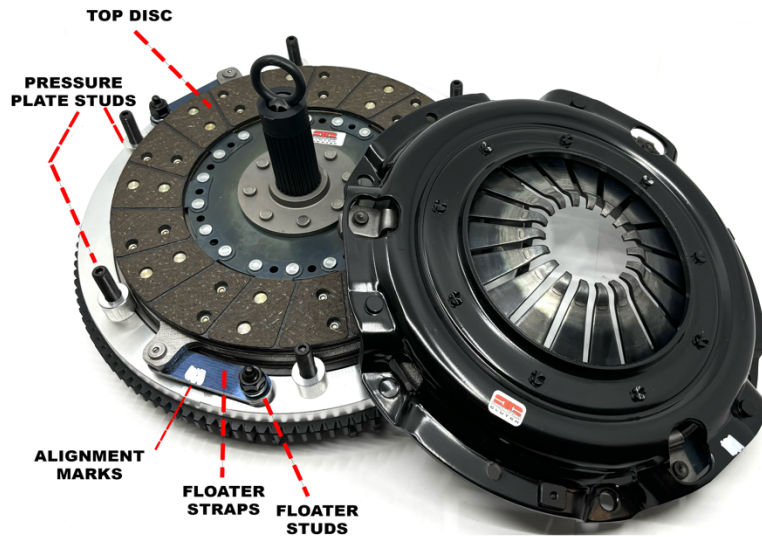

Figure 2

- 4) Remove the three nuts and lock washers that hold the floater straps onto the flywheel. Remove the floater assembly. Note the straps on the floater are on the flywheel side. There are six large studs and three small studs in the flywheel. There is a series of stands and shims on these studs. Do not mix these parts. Install nuts onto studs to prevent the stands and shims from falling off the studs during flywheel installation!
- 5) Remove the bottom disc. Also note “Flywheel Side” on the disc center. See Figure 3

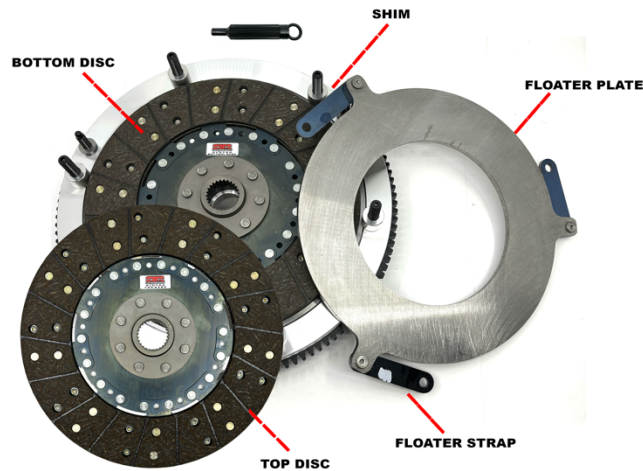

Figure 3

- 6) Inspect the crankshaft at this time. Remove any dirt from the crank and clean the pilot hole. A wire brush can be used. Inspect the pilot bushing, if worn or damaged replace it at this time. Install flywheel onto crank using high quality crank bolts. Torque bolts to factory specifications.
- 7) Remove the three small nuts from the floater studs and lock washers. Be sure the shims do not fall off the studs.
- 8) Install the bottom disc with the sticker on the flywheel side towards the engine. Install the floater onto the studs. Be sure to note the alignment marks. Floater straps must be on flywheel side. Install the three nuts and tighten to 25 ft. lbs. Check disc clearance at this time. Insert the pilot tool and rotate the disc. There should be a slight amount of front to back movement. If there is more than .025" clearance the floater will push the top disc into the pressure plate, resulting in no clutch release. If the clearance is less than .020" the bottom disc will drag on the flywheel and the floater resulting in no clutch release. If there is too much or too little clearance you may have dropped some of the shims or placed them on the wrong stud. Call the factory tech line before you proceed further. If all is correct re-tighten the three floater nuts on each stud to 25 ft. lbs. **Do not use Loctite on these nuts!**



- 9) Install top disc. Be sure the "Flywheel Side" sticker on the disc is to the engine. Insert and rotate the pilot tool all the way into the pilot bushing to align both discs. Remove the nuts and flat washers from the six large studs. Do not allow the stands or shims to fall off the studs.
- 10) Install the pressure plate onto the six studs. Be certain to note the alignment marks. Install washers, lock washers and then nuts onto the studs and tighten to 35 ft. lbs. **Do not use Loctite on these six pressure plate studs!**
- 11) Complete the bell housing, transmission and driveline installation.

Important Clutch Installation Hints

The following check list is a reminder of the necessary inspection points and precautions required to insure a trouble-free clutch installation.

Installation / Do's

- 1) Determine cause of original clutch failure. Cause of first clutch failure (if not wear) MUST be found and corrected. If oil is present on clutch plate, cause of leak MUST be corrected before installation of new clutch unit.
- 2) Check splines on transmission input shaft for signs of abnormal wear or twisting. Slide new disc on spline by hand gently to check fit. Disc should move FREELY on splines.
- 3) Remove ALL oil or grease from friction surfaces on flywheel and cover assembly. Surfaces MUST be clean and dry. Also clean input shaft spline with a wire brush. Lubricate with dry graphite spray if needed.
- 4) To insure proper operation, friction surface of flywheel MUST be resurfaced. Check dowel pins, they must be smooth and straight.
- 5) If throw-out bearing is worn, replace it, better now than later.
- 6) Closely inspect pilot bearing or bushing for excessive wear to avoid transmission shaft misalignment. Replace it if any doubts.
- 7) Use clutch alignment tool to insure disc and cover are properly aligned with pilot bearing.
- 8) If using an aftermarket scatter shield/bell housing, checking center hole run-out is highly recommended.
- 9) Be sure all special type bolts, if any, are replaced in their proper locations.
- 10) Torque all clutch cover bolts evenly, to factory recommended spec, using a progressive "criss-cross" tightening pattern.
- 11) Before completing installation, inspect all clutch linkage parts (fork, clevis, pins, etc.) for signs of wear and replace ALL worn pieces. Grease all pivot points in linkage system.
- 12) Adjust clutch pedal "free play" to correct specifications. Throw-out bearing should not be tight against clutch fingers. 1/8" – 1/4" is recommended, except cable linkage.

Installation / Don'ts

- 1) Don't let any grease or oil contact ANY friction Surface.
- 2) Don't use an impact (air gun) to tighten cover bolts.
- 3) Don't let transmission weight rest on input shaft during installation.

Torque Specs

5/16-18 Grade 8	25 Ft/Lbs
3/8-16 Grade 8	35 Ft/Lbs
7/16-20 Grade 8	65 Ft/Lbs
1/2-20 Grade 8	75 Ft/Lbs

Limited Warranty

Competition Clutch, products are warranted to be free from defects in material and workmanship for the period of ninety (90) days, from the date of purchase. Competition does not warrant or make any representations concerning its products when not installed and or used strictly in accordance with the manufacturer's instructions for such; installation and operation, and in accordance with good installation and maintenance practices of the automotive industry. Products purchased used do not carry a warranty. This warranty is to the original purchaser and is non-transferable.

Competition Clutch will not be held liable for the labor charges and other intangible or consequent losses that might be claimed as a result of the failure of any part, nor shall it be liable for damages or injury to persons or property resulting from the misuse or improper installation of any part subject to this warranty. No merchandise may be returned for any reason unless prior return merchandise authorization number (RMA) has been obtained from Competition. An RMA number may be obtained via www.competitionclutch.com or by calling Competition directly.

Competition Clutch reserves the right to examine all parts returned for warranty claim to determine whether or not any such part has failed because of a defect in material or workmanship. Competition's obligation under this warranty shall be limited to repairing, replacing or crediting, at its option, any part found to be defective. All products returned to Competition for warranty inspection must be prepaid by the customer under this warranty.

In a racing environment, the type of stress placed on automotive parts can vary dramatically by the type of use, driving style, track preparation, differing tire style and other variables that are out of Competition's control. For this reason, any parts used in a racing environment shall be void of any warranty either expressed or implied.

There are no other warranties, either expressed or implied including, but not limited to, warranty of merchantability, and warranty of fitness for a particular purpose which extend beyond those set forth in the preceding paragraphs. This warranty shall be interpreted and applied in accordance with California law.

For any changes or updated versions of the warrant described above, please refer to www.competitionclutch.com before installation of product.

I00125