

## Specifications

Part #:	54901U	54903U	54901U-904	54903U-904
Deck Height:	9.750"	9.240"	9.750"	9.240"
Bore Size:	4.120"	4.120"	4.120"	4.120"
Bore Finish:	Bored	Bored	Bored	Bored
Liner Length:	6.38"	5.87"	6.38"	5.87"
Cyl. Wall Thickness:	.925"	.925"	.925"	.925"
Weight:	124 lbs.	115 lbs.	124 lbs.	115 lbs.
Deck Thickness:	.750"	.500"	.750"	.500"
	*Ra: 0.4 µm +0.25/-0.15 µm			
	<b>See Illustration A for deck height measurements.</b>			
Material:	A357-T6 Aluminum			
Liner O.D.:	4.305"			
Parent Bore Thickness:	.200"			
Stroke:	Tall Deck – 4.600" (may require final notching of liners for rod clearance) Standard Deck – 4.250" (may require final notching of liners for rod clearance)			
Camshaft Position:	Raised .388"/9.86mm (requires 2 extra links in timing chain)			
Cam Thrust Plate:	RHS #549102 included with block			
Rear Cover:	RHS #549101 included with block			
Cam Bearing:	Durabond Babbit Bearing – installed and microfinished for 55mm cam			
Lifter Bores:	Machined for .842" lifter (material to use 1.060" bushing for key lifter) or .904" lifter if -904 block			
Lifers Style:	Requires tie bar style lifer (will not accommodate OE trays)			
Main Bearing Bore:	2.751" +/- .0003" (69.88 mm +/- .009)			
Main Caps:	8620 Billet			
Main Studs:	ARP 2000 7/16"-20 x 5.150" x 7/16"-14			
Main Bolts:	ARP 8740 3/8"-16 x 1.250"			
Oil System:	Priority Main Oiling with -12 AN provisions front and rear			
Oil Pan:	Stock bolt pattern, pan will depend on stroke/rod clearance requirements			
	<b>See Illustration B.</b>			
Head Studs:	6-Bolt LSX Pattern- M11 x 2.0 & M8 x 1.25			
Freeze Plugs:	Threaded -12 AN (included with block)			

## Features

- Standard and 9.750" Tall Deck
- Long Arm Friendly – Engineered to Clear 4.600" Stroke with 2.100" Rod Pin and 60mm Cam
- Priority Main Oiling – Dry Sump Friendly, Front & Rear -12 AN Fittings Feeds and OEM Feed
- Raised Cam Centerline – Accommodates Up to a 60mm Cam with 4.600" stroke
- 6-Head Bolt Design with Full Water Jacket Around Cylinders
- Chilled Main Bearing Bulkheads
- Improved Bay-to-Bay Breathing

## Tech Notes

<b>Heads:</b>	Any LS head with stock or GM LSX 6 bolt pattern	
<b>Crankshaft:</b>	4.600" Stroke should have 3.52" cheek radius max.	
<b>Cranks Sensor:</b>	Stock Gen III/Gen IV depending on controller (will require plugging if not used)	
<b>Cam Sensor:</b>	All blocks are machined for Gen III cam sensors. However, the standard deck blocks will require a spacer to accommodate the raised cam; tall deck is a drop-in application. Gen IV will require modifying the front cover to reposition the sensor for the raised cam. <b>End user must verify Camshaft sensor to sprocket location before final assembly</b>	
<b>Knock Sensor:</b>	Machined for Gen III & Gen IV knock sensors	
<b>Valley Cover:</b>	Gen III or Gen IV valley cover	
<b>Front Cover:</b>	Gen III & Gen IV covers will fit. Gen IV-style cover will require modification of cam sensor location to accommodate the raised cam or purchase of COMP #5496/5497. (Aftermarket and distributor drive covers will require modification for raised cam.)	
<b>Timing Chain &amp; Sprockets:</b>	Raised cam will require chain with 2 extra links. Single roller will clear front cover, oil pump and the block. Double roller will require spacing of oil pump and checking clearance of the front cover. Specific timing sets available from COMP Cams.	
<b>Valve Train:</b>	Utilize valve train for selected heads with pushrod length sized accordingly for raised cam	
<b>Lifters:</b>	Requires revised dog bone or tie bar lifter design (stock lifter trays will not work)	
<b>Water Pump:</b>	Utilizes stock LS water pump	
<b>Windage Tray:</b>	Long stroke may require shimming of windage tray	
<b>Piston Oil Squirter:</b>	Priority Main oiling system requires only 4 piston squirters with cross over design. Oil hole provision is only a pilot hole and will require drilling into oil galley to activate.	
<b>Engine Mounts:</b>	Machined for Gen III & front engine mounts, provisions for Gen 1 mounts are spot drilled and will require drill and tapping and may break into waterjacket. In the event that these holes break into the water jacket, apply sealant to these fastners. We also recommend installing a flush stud into the Gen III hole adjacent to the Gen 1. Hold to add backup for the bolt. <b>Also provisions for front motorplate race mounts. See Illustration C.</b>	
<b>Block Heater:</b>	The factory block heater will not thread into the hole in the stock location. Modifications will need to be made to thread into the -12AN hole.	
<b>Oil Dipstick:</b>	Provision for stock oil dipstick, this hole will require plugging if not used.	
<b>Oil System:</b>	The RHS priority main oiling system has eliminated the stock "barbell plug" and replaced it with a stepped 1/2"-3/8" NPT plug design to eliminate the restriction created by the "barbell" body using the external -12 feed. <b>See Illustrations D &amp; E.</b>	
<b>Oil Pressure Sensor:</b>	The RHS block is designed to use the Gen IV oil sensor, if using a Gen III cover and the GM or equivalent screw in oil pressure sensor you will need to drill and tap the block. Maximum recommended sensor size is M16 or 3/8 NPT. <b>See Illustration F</b>	
<b>Torque Specifications:</b>		
<b>Main Studs:</b>	95 ft./lbs. Utilizing ARP Ultra Torque Lube	(129 Nm)
	(Torque in 3 equal steps using the standard main cap tightening sequence)	
<b>Main Cross Bolts:</b>	35 ft./lbs. Utilizing ARP Ultra Torque Lube	(48 Nm)
<b>Cam Thrust Plate:</b>	18 ft./lbs.	(25 Nm)
<b>Rear Cover:</b>	18 ft./lbs.	(25 Nm)
<b>Head Stud Torque:</b>	Use fastener manufacturer recommended installation, sequence, torque and lubricant.	

## Suggested Components

Part Type	Brand/Part #	Description
<b>Torque Plate Set:</b>	RHS #549150	LS Torque Plate Set
<b>Main Cap Puller:</b>	RHS #549106	LS Engine Main Cap Puller
<b>Head Gasket:</b>	RHS #549400-L	RHS LS Head Gasket 4.00" Bore-Left
	RHS #549400-R	RHS LS Head Gasket 4.00" Bore-Right
	RHS #549401-L	RHS LS Head Gasket 4.165" Bore-Left
	RHS #549401-R	RHS LS Head Gasket 4.165" Bore-Right
	RHS #549402-L	RHS LS Head Gasket 4.200" Bore-Left
	RHS #549402-R	RHS LS Head Gasket 4.200" Bore-Right
	<a href="#">See Illustration G.</a>	
<b>Timing Set:</b>	RHS #3154	COMP Cams Double Roller Timing Chain Set
	RHS #3173KT	COMP Cams Double Roller Adjustable Timing Chain Set
	RHS#9302	RHS Single Row Replacement Timing Chain (chain only)
	RHS#9132	RHS Double Row Replacement Timing Chain (chain only)
<b>Front Cover:</b>	COMP #5496	Front Timing Cover with Raise Cam Sensor Mount for LS1,2,3, and 6 oil pumps
	COMP #5497	Front Timing Cover with Raise Cam Sensor Mount for LS7 oil pumps
<b>Lifters:</b>	COMP #15956-16	.842" Short Travel Hydraulic Lifter (captured link bar)
	COMP #8956-16	.842" Endure-X Mechanical Roller (drop off link bar type)
	COMP #98956-16	.842" Elite Race Mechanical Roller (captured link bar type)
	COMP #98954-16	.875" Elite Race Mechanical Roller (captured link bar type)
	COMP #98952-16	.904" Elite Race Mechanical Roller (captured link bar type)
<b>Piston Oilers:</b>	RHS #549120	Piston Oiler Set, Includes All Four Oilers and Metering Bolts
<b>Assembly Lube:</b>	COMP #102	COMP Engine Assembly Lube 4 oz. jar
	COMP #104	COMP Engine Assembly Lube 8oz. Jar
	COMP #127	COMP Engine Assembly Lube 16 oz. Tube
	COMP #100-9908	ARP Ultra Lube Torque Lube .5 oz.
<b>Intake Spacer</b>	RHS #549107	LS1 Intake Spacer Kit for 9.750" Deck
<b>Plates:</b>	RHS #549108	LS3 Intake Spacer Kit for 9.750" Deck
	RHS #549109	LS7 Intake Spacer Kit for 9.750" Deck

## Service Items

Part Type	Brand/Part #	Description
<b>Liners:</b>	RHS #54901CL	4.040" Bore Tall Deck Outer Right Liner (Cylinders #2 & #7)
	RHS #54904CL	4.040" Bore Tall Deck Outer Left Liner (Cylinders #1 & #8)
	RHS #54900CL	4.040" Bore Tall Deck Inner Liner
	RHS #54903CL	4.040" Bore Standard Deck Outer Right Liner (Cylinders #2 & #7)
	RHS #54905CL	4.040" Bore Standard Deck Outer Left Liner (Cylinders #1 & #8)
	RHS #54902CL	4.040" Bore Standard Deck Inner Liner
	RHS #54906CLSB	3.840" Bore Standard Deck Outer Right Liner (Cylinders #2 & #7)
	RHS #54907CLSB	3.840" Bore Standard Deck Outer Left Liner (Cylinders #1 & #8)
	RHS #54902CLSB	3.840" Bore Standard Deck Inner Liner
<b>Rear Cover:</b>	RHS #549101	Rear Cover Seal & Fasteners
<b>Cam Thrust</b>	RHS #549102	Brass Cam Thrust Plate 6 Bolts
<b>Plate:</b>	RHS #549204-1	Thrust Plate O-Ring
<b>Cam Bearings:</b>	RHS #549202-1	Replacement Cam Bearing-Finished I.D.
<b>Main Caps:</b>	RHS #549100-1	8620 Billet Main Cap
<b>Main Dowel :</b>	RHS #549201-1	Main Dowel Pin
<b>Main Studs:</b>	RHS #549300-1	Main Cap Stud, Long
	RHS #549301-1	Main Cap Stud, Short
	RHS #549302-1	Main Cap Side Bolt
	RHS #549303-1	Main Cap 12pt Nut
	RHS #549304-1	Main Cap Washer
	RHS #549305-1	Main Cap Side Washer
<b>Transmission</b>	RHS #549205-1	Block-To-Transmission Dowel Pin
<b>Freeze Plugs:</b>	RHS #549203-1	Threaded -12 AN Plug
	RHS #549203-1	O-Ring

Illustration A

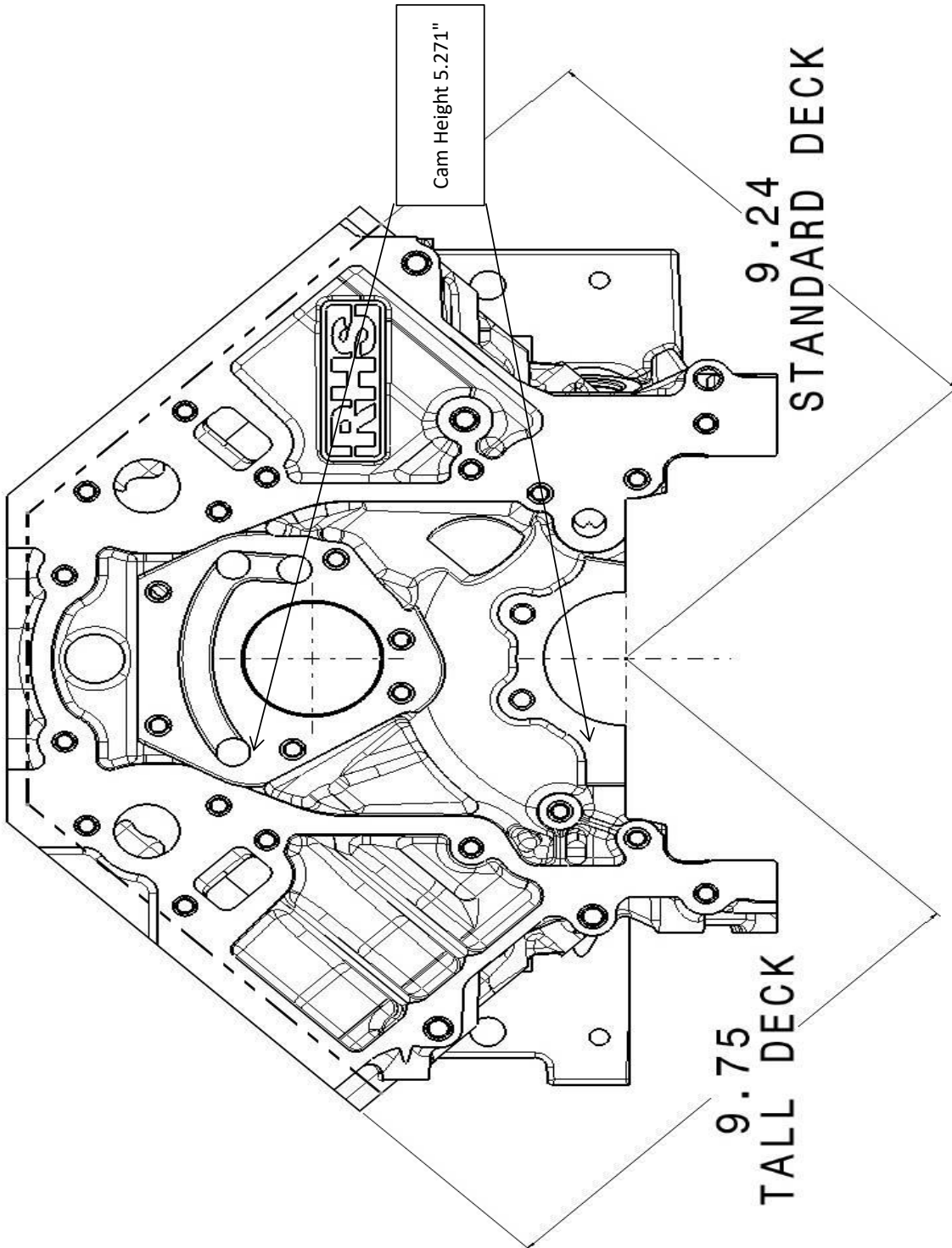

Illustration B

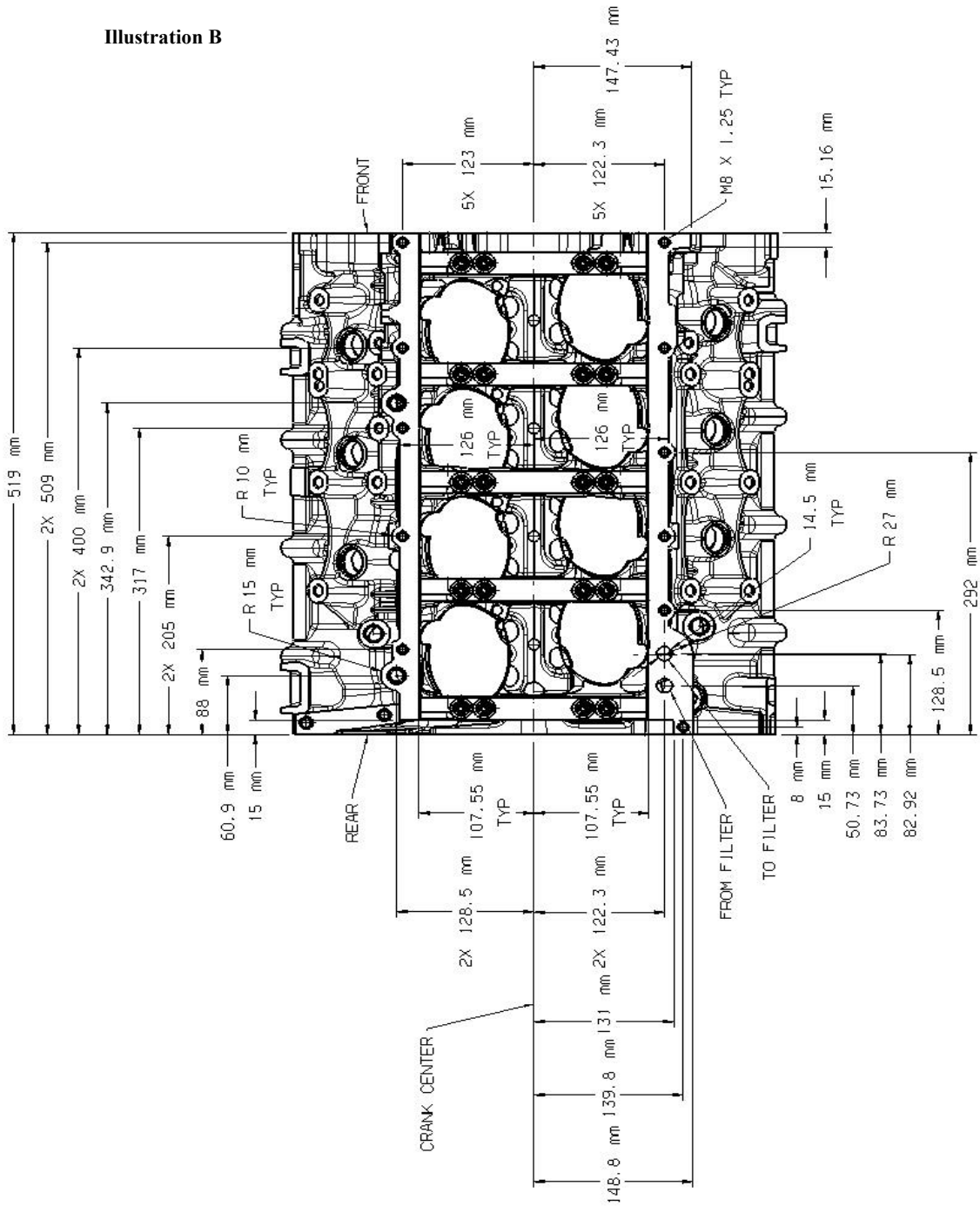
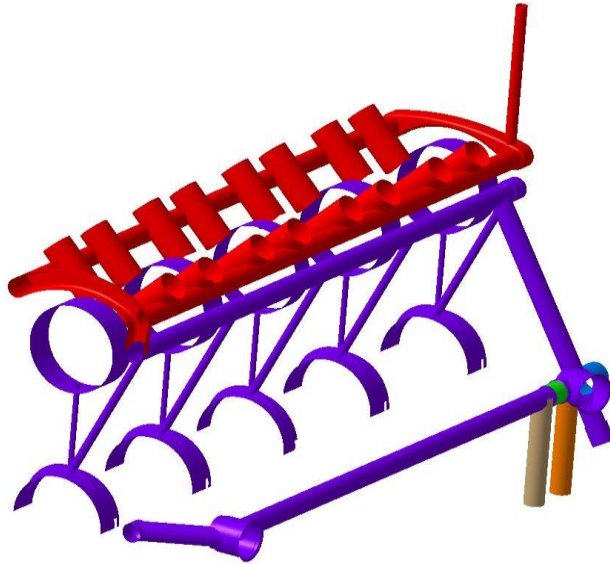



Illustration D



### Barbell plug replaced with NPT plugs

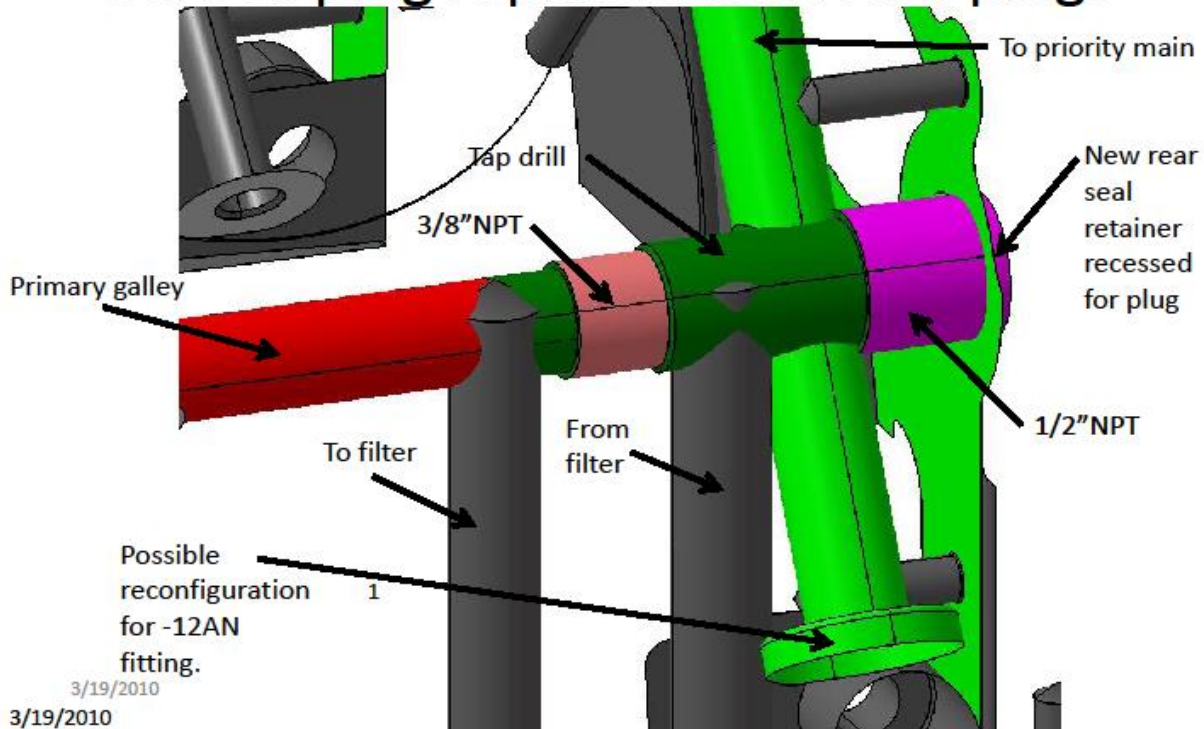
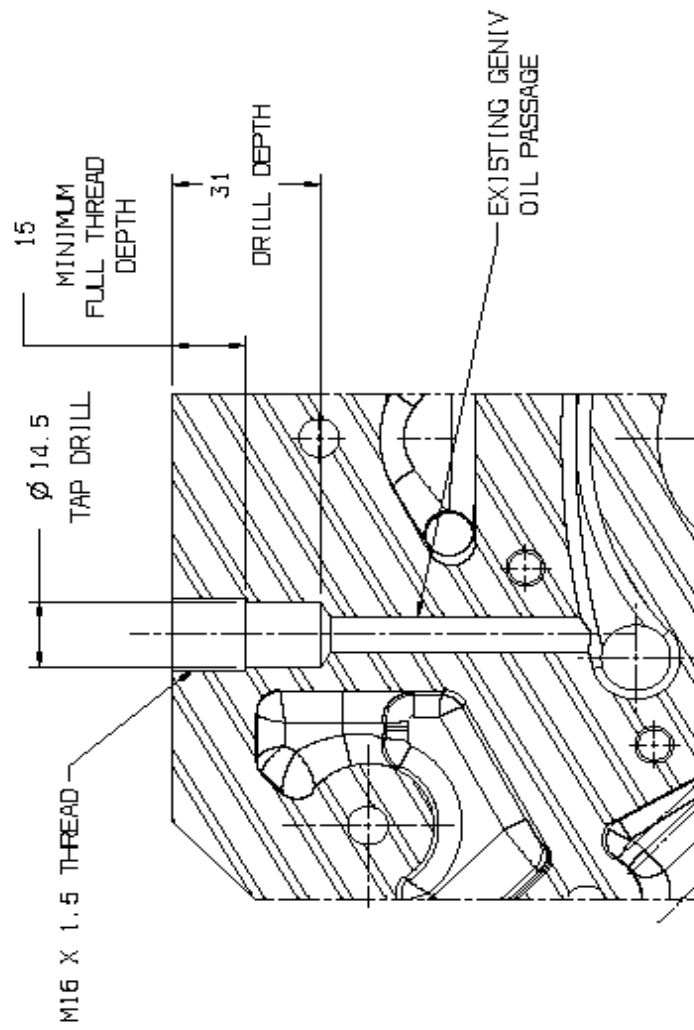
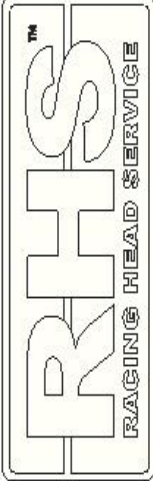

Illustration F

RHS BLOCK - DRILL AND TAP FOR GM12569323 OR EQUIVALENT  
OIL PRESSURE SENSOR FOR USE WITH GENIII VALLEY COVER  
AND M16 METRIC THREADS.





NOTE: ALL DIMENSIONS ARE NOMINAL.

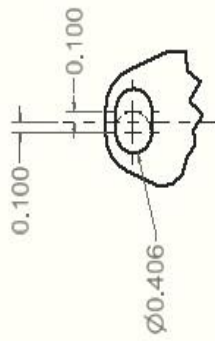

Ø0.387  
4X

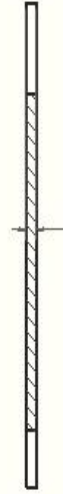
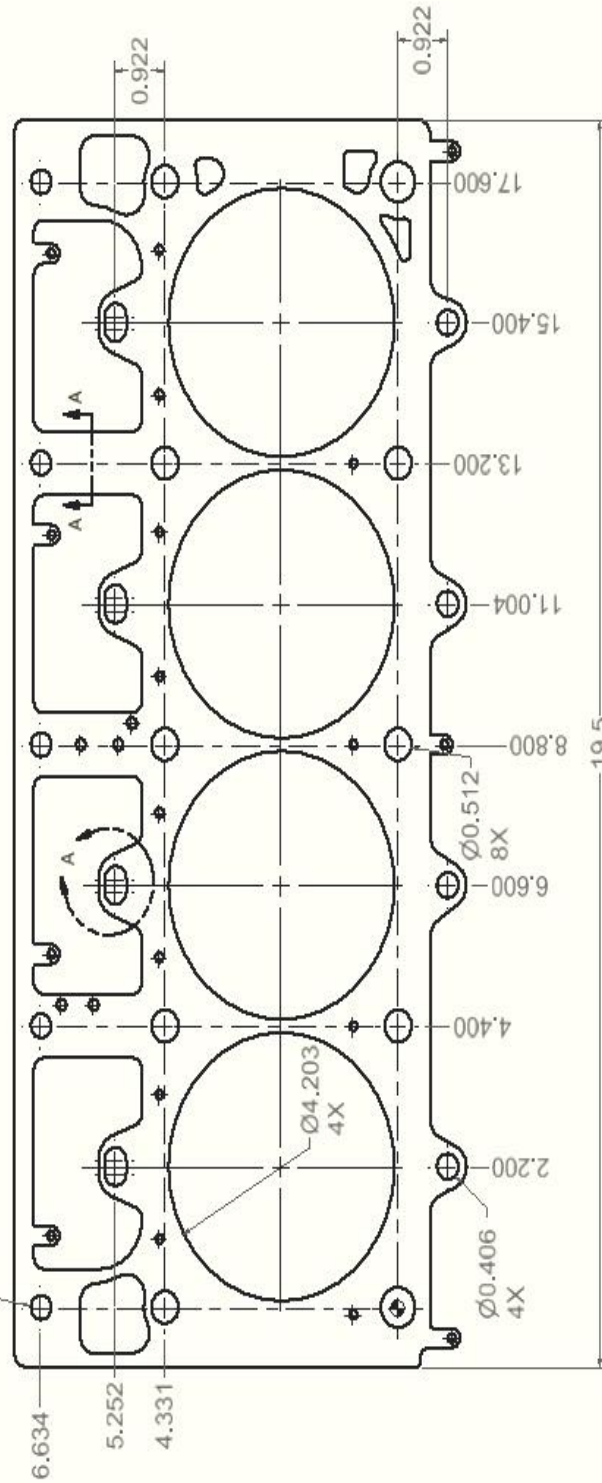

0.036  
COMPRESSED THICKNESS  
WITHOUT STOPPER THICKNESS (0.005)

Illustration G

