



INSTALLATION GUIDE

PART NUMBER: 6525
FLIP KIT
GM 1500 ALL CABS | 2014-2018

300 W. PONTIAC WAY. CLOVIS, CA 93612
PHONE: 800-445-3767 | EMAIL: INFO@BELLTECH.COM

THANK YOU

Thank you for choosing our high quality Belltech product. We have spent a great deal of time developing our line of products so that you will receive maximum performance with minimal difficulty during installation. Soon your vehicle will be on the road looking and feeling much improved.

Please take a moment to read all instructions and warnings prior to installation of your new Belltech product and before operating your vehicle. If you have any questions or concerns regarding any step in the installation process, please do not hesitate to call or email our customer support specialists who are trained to help you through any portion of this process.

Before You Begin:

It is of the utmost importance that you confirm all of the components listed on the parts list is in the kit. You can find this list located on the last page(s) of your instructions. Do not begin installation if any part is missing. Instead, please call our Belltech customer service specialists.

Belltech Customer Support:

Phone: 1-800-445-3767

Email: info@belltech.com

Safety Information:

Warning: Do not work under a vehicle supported only by a jack. Place support stands securely under the vehicle in the manufacturer's specified locations unless otherwise instructed.

Proper use of safety equipment and eye/face/hand protection is absolutely necessary when performing any of the following instructions.

We strive for an exceptional experience for all our valued customers. If for any reason you need assistance with your Belltech products, please do not return the product to the store you purchased from, but rather call our dedicated customer service experts, from 7am to 5pm PST.

We recommend that a qualified mechanic, at a properly equipped facility, perform this installation.

It is very helpful to have an assistant available during installation.

Before Driving Your Vehicle:

It is important to double check all brake hoses, cables, and other components to be sure there is no interference. You must also check for wheel/tire to chassis/body interference. If any issues are found, review your installation instructions to be sure no steps were missed and any problems are corrected.

Make sure your vehicle is aligned immediately following installation.

Check all hardware and torque at intervals for the first 10, 100, and 1000 miles.

Some of Belltech's products are designed to improve your vehicle's off-road performance. Leveling/lifting your vehicle may result in an altered center of gravity. It is crucial to use extreme care when operating your vehicle to prevent rollover and/or loss of control.

Any changes in your vehicle's suspension may result in transformed handleability. Please test drive your vehicle in a remote location so you can become accustomed to the revised driving characteristics.

Perform headlight check and adjustment.

Failure to drive any modified vehicle in a safe manner may result in harm or death.

Never operate your modified vehicle under the influence of drugs, alcohol, or lack of adequate sleep.

Always wear your seatbelt.



DIFFICULTY:

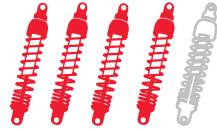

INSTALLATION TIME:

5-6 Hours

RECOMMENDED TOOLS:

- Properly rated floor jack
- 6 Support stands
- Wheel chocks
- Wrench set
- Socket wrench set
- Flat head screw driver
- Safety glasses
- Tape measure
- Die grinder with abrasive cut-off wheel
- Power drill and drill bits
- 3/8"-16 tap and die
- Large C-clamps
- Medium weight ball peen hammer and center punch
- Air powered impact wrench
- Air powered chisel
- Transmission jack
- 1/2" drive torque wrench up to 200 ft lbs.



Installation Note:

- It is suggested to begin this procedure with the vehicle fuel tank on low to reduce the weight needing to be supported on the transmission jack during installation.
- Modification of the OEM exhaust tip may be required to provide adequate clearance when installing this kit.

INSTALLATION PREPARATION:

Before beginning the installation process, measure the hub to fender heights for your vehicle and record them in the "Before" section. After your vehicle has been modified, record the new measurements in the, "After" section. This way, you can compare the resulting height to the original. When taking the measurements, measure vertically from the center of the wheel to the inner edge of the fender.

Before:

LF: _____

RF: _____

LR: _____

RR: _____

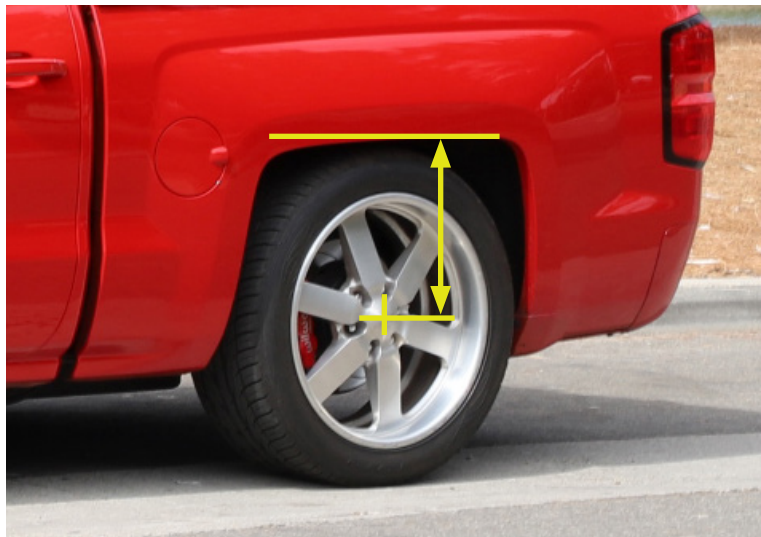

After:

LF: _____

RF: _____

LR: _____

RR: _____

JACKING, SUPPORTING, AND PREPARING THE VEHICLE

1. Park your vehicle on a smooth, level, concrete or seasoned asphalt surface.
2. Block the front wheels of the vehicle using wheel chocks. Make sure the vehicle's transmission is in "PARK" (automatic) or 1st gear (manual).
3. Activate the parking brake.
4. Break loose, but do not spin the wheel lug nuts to ease in removal when the wheels are in the air.
5. Lift the rear of the vehicle off the ground using a properly rated floor jack. Lift the vehicle so the rear tires are approximately 6-8 inches off the ground.
6. Place support stands rated for the vehicles weight. The stands should be positioned, two on each of the frame rails, just forward of the front leaf spring hangers and just below the rear leaf spring shackle hangers. Prior to lowering the vehicle onto stands, make sure the support stands will contact the chassis. It is very important that the vehicle is properly supported to prevent any harm to ones self or to the vehicle.
7. Place a support stand under each side of the axle to support the weight of the axle. Make sure these are only supporting the weight of the axle; allowing the other 4 support stands to support the frame.
8. Lower the vehicle slowly onto the stands.
9. Remove the rear wheels.



Technician reminder:

Never work under a vehicle supported only by a jack. It is necessary to place support stands securely under the vehicle in the manufacturer's specified locations unless otherwise instructed.

TRAILER HITCH REMOVAL

10. If your vehicle is equipped with a trailer hitch, it must be temporarily removed to reduce interference during the installation. This also adds access when mounting the rear shackle hardware.
11. Disconnect the hitch wiring plug, as shown in the image below.



12. Remove the 21mm nuts and bolts from the trailer hitch. There is a total of six, three (3) per side.



13. Lower and detach the trailer hitch from the vehicle. Place the hitch and hardware out of the way.



FUEL TANK REMOVAL



Technician reminder:

To access the front driver side the leaf spring bolt, the fuel tank must be temporarily lowered.

14. Remove and set aside the bolts securing the protective shield that shrouds the fuel tank. There are three mounting bolts on the driver side that are attached to the chassis.



Technician note:

Some 2016 and 2017 model year vehicles may not be equipped with the protective shield. If the shield is not present, proceed Step 16.



15. Lift the opposite side of the protective shield upward to clear the rectangular hooks and detach the protective shield. Set the shield aside and place the three mounting bolts back in their respective holes for safe keeping.



16. Properly support the fuel tank from underneath with a transmission jack or another height adjustable component.
17. Remove the two bolts holding the fuel tank straps that are mounted at each end of the tank. They are located on the driver side between the tank and the chassis. One end of the strap is mounted directly to the chassis; the opposite end is attached by a hook.

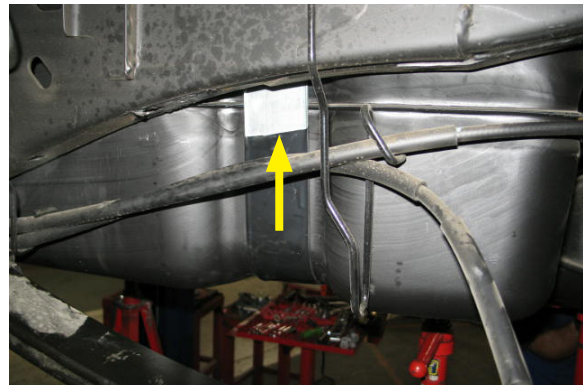

FUEL TANK REMOVAL CONTINUED

18. Pull the straps down from the driver side and unhook the straps from the opposite end to detach the straps from the fuel tank.
19. Behind the fuel door, remove the three bolts that secure the fuel nozzle intake.



20. Slowly lower the fuel tank between 6 to 12 inches, pulling the rubber fuel neck down as the tank travels down. When lowering the tank, ensure there are no hoses or lines that are under tension. Detach hoses and lines if necessary to ensure the lines are not damaged.



Technician warning:

WARNING: Use caution when working around an open fuel source. It is highly recommended to temporarily cover or plug the opening on the fuel tank.

REAR SUSPENSION REMOVAL

21. Support the axle using a floor jack so that it can be raised and lowered. Additionally, support the rear axle near the rear U-joint to keep the axle from rotating.

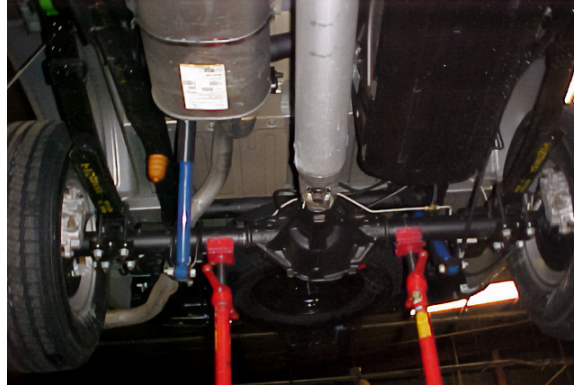

22. Remove the upper and lower 18mm nuts and 15mm bolts to detach the rear shock assemblies from the vehicle.

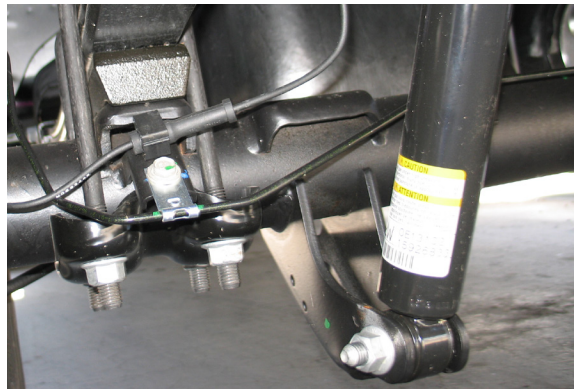

23. Remove the 21mm U-bolt nuts, lower plate, and U-bolts to detach the rear axle from the leaf springs.



24. Use the floor jack to lower the rear axle just enough to remove the original leaf spring blocks from the axle. The blocks will not be used in the Belltech kit.

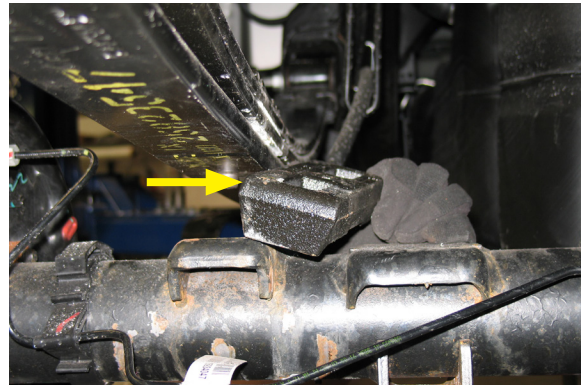

REAR SUSPENSION REMOVAL CONTINUED

25. Use the floor jack to raise the rear axle just enough to remove the load from the shackles. Break loose but do not remove the rear leaf spring mount bolts and the shackle mount bolts.



Technician warning:

Leaf springs may be under significant tension and can store substantial energy. Exercise extreme caution during the following steps to avoid personal injury and/or vehicle damage. Take care to prevent damage to brake hoses and the driveline while relocating the rear axle assembly.

26. At the front end of the leaf springs remove the 21mm nuts and bolts from the hangers. With the fuel tank lowered on the driver side, there is enough clearance to remove the bolt. Once the hardware is removed, the leaf springs will rest on top the axle.

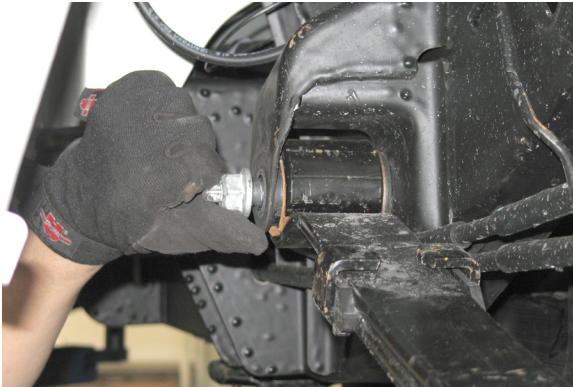

27. At the rear end of the leaf springs remove the 21mm nuts and bolts from the lower shackle to hanger only.



28. Mark the leaf springs with left, right, front, and rear to confirm their locations when placed back on the vehicle.

29. Detach both leaf springs from the vehicle. If necessary, lower the axle to gain clearance.

30. Remove the 21mm nuts and bolts from the shackles to leaf springs to detach the shackles. Note the direction of the bolt head as the bolt will need to be placed the same direction.



REAR SUSPENSION REMOVAL CONTINUED

31. The leaf spring center bolts must be inverted. Use a pair of C-clamps to hold the spring pack while the spring is modified.



32. Use vise-grip locking pliers to hold the round head of the center bolt and remove the 1/2" nuts.



33. Remove and discard the U-bolt support plate. Assemble the leaf spring with the center bolt inverted, round bolt head at the top.

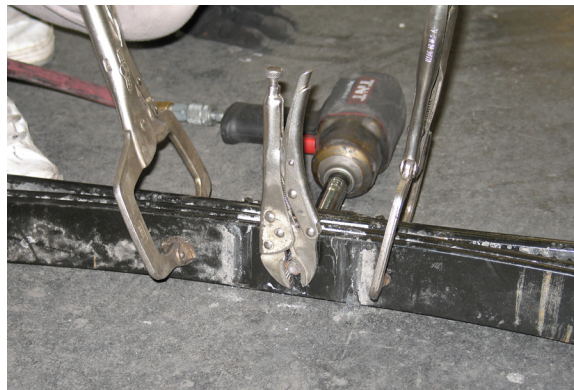

34. Locate the speed sensor and brake line bracket beneath the rear axle spring pad and remove the lines from the bracket. Using a cutting tool, remove the bracket from the axle. Grind smooth all cut areas, clean the surfaces, and apply spray paint to prevent corrosion. The new Belltech axle saddles include an integrated bracket for reattaching the lines.

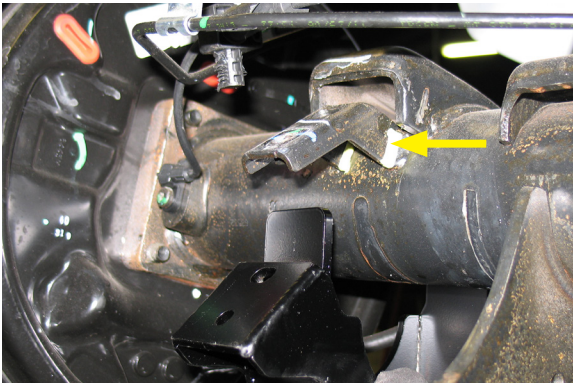

REAR SUSPENSION REMOVAL CONTINUED

35. The original bump stop mount must be removed from the chassis. Using an abrasive cutting wheel, carefully cut through the welds around the bump stop mount to remove it from the chassis. Do not cut into the chassis itself.



36. After the welds have been cut, use a hammer and chisel to separate and remove the mount from the chassis.



37. Using an abrasive grinder, smooth and clean any remaining excess material left on the chassis after the mount has been removed. Apply black spray paint to all exposed bare metal surfaces to protect against corrosion.

38. Drill a new 5/16" pilot hole for the supplied Belltech bump stop. Position the hole centered over the axle so the bump stop will contact the axle bump pad correctly. Tap the hole using a 3/8"-16 tap.



REAR SUSPENSION REMOVAL CONTINUED

39. The original rear leaf spring hangers must be detached from the chassis. Remove the 15 mm bolt on the rear leaf spring hangers.



40. Use a cut-off wheel or an abrasive cutting tool to cut a slot through the heads of the rivets. There are three each on each rear hanger. The slots must be cut straight through the rivet heads and flush with the surface of the hangers.

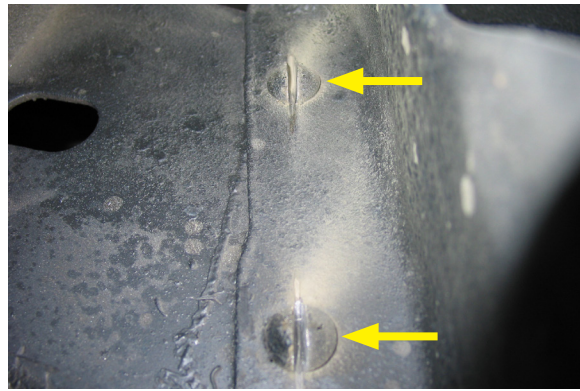
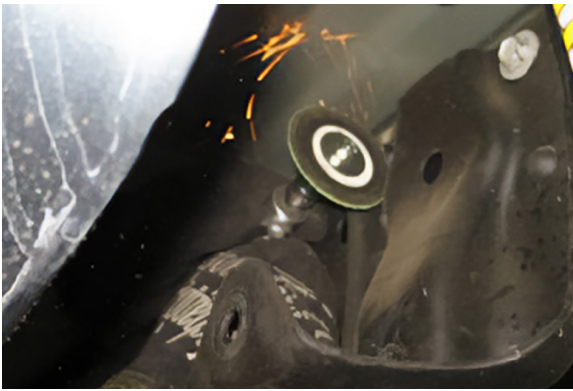

41. With a pneumatic hammer and chisel attachment, remove the rivet heads. Once the rivet heads have been removed, use a punch and hammer or a punch with the air hammer to push the rivets through the chassis. Detach the hangers from the chassis.



Technician note:

If the rivet heads cannot be easily removed with a chisel, the relief cut through the center of the rivet is likely not deep enough. Increasing the depth of the center cut will reduce the effort and time required to remove the rivets. Do not cut completely through the hanger bracket.



REAR SUSPENSION REMOVAL CONTINUED

42. The rear hanger support bracket must also be removed. This is mounted by a small weld to the chassis and mounted with a heavy-duty rivet. Use a cut-off wheel or an abrasive cutting tool to cut a slot through the heads of the rivet. The slot must be cut straight through the rivet head and flush with the surface.



Technician note:

Some models may not be equipped with a rivet at this location. Instead, the component may be secured with small welds that must be removed.

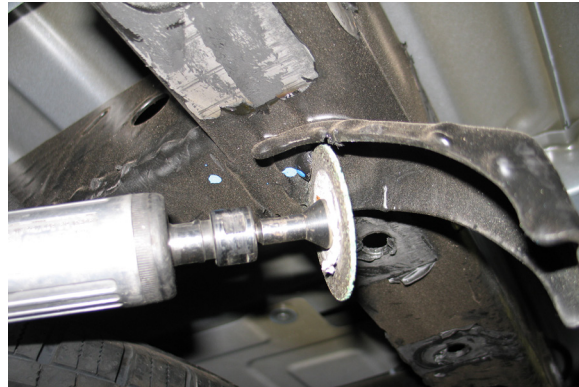

43. Use a hammer, channel-locks, or vice-grips to pull and push the support bracket upwards towards the spare tire. Continue to pull back and forth until it breaks free.



FLIP KIT INSTALLATION

44. Attach the shackles to Belltech hangers, part# 6519-010-99, with the original hardware. The shackle bushing is attached to the hanger as the new hanger will be inverted on the chassis compared to the original hanger. Do not torque yet.

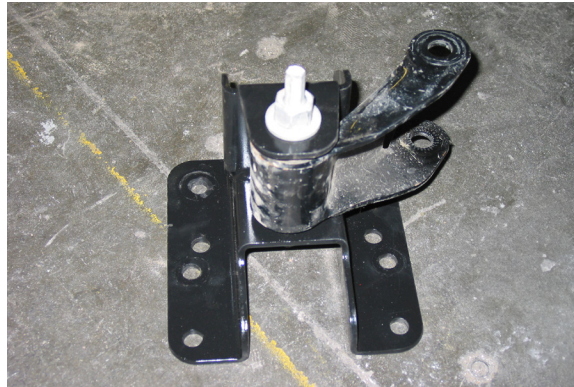

45. The new Belltech hangers have four (4) sets of mounting holes. Using the top hole and the third hole from the top will lower the vehicle 5". Using the second and fourth holes from the top will lower the vehicle 6". The underside bed flange may need to be slightly bent to provide additional clearance when installing the hanger in the 6" position.

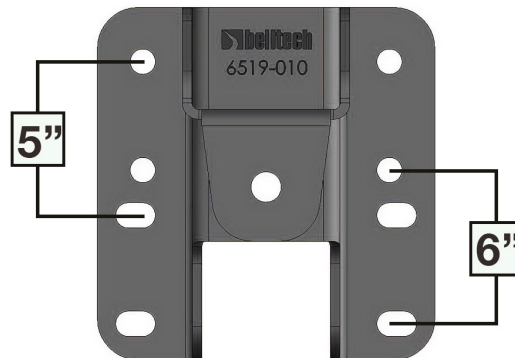

46. Attach the hangers to the chassis with supplied 7/16"-20 x 1-1/4" bolts, 7/16" washers, and 7/16" stover lock nuts. The supplied hardware is fastened at the holes where the rivets used to be. Also use the original 15 mm bolts on the original location on the chassis. Torque the bolts to 60 ft lbs.



FLIP KIT INSTALLATION CONTINUED

47. Begin with the front leaf spring mounts. With the gas tank still slightly lowered, use the original leaf spring mounting hardware from the fuel tank side, passing outward through the frame and the leaf spring eye. Fasten the lock nut hand-tighten only. Do not torque at this time.



48. Swing the rear of the leaf spring upward to the shackle. The leaf spring will now sit underneath the rear axle. Align the rear leaf spring eye with the shackle bolt hole.
49. Fasten the leaf springs to the shackles with the original nuts and bolts and but do not torque yet. The final torque will be done once the vehicle has been lowered to the ground.

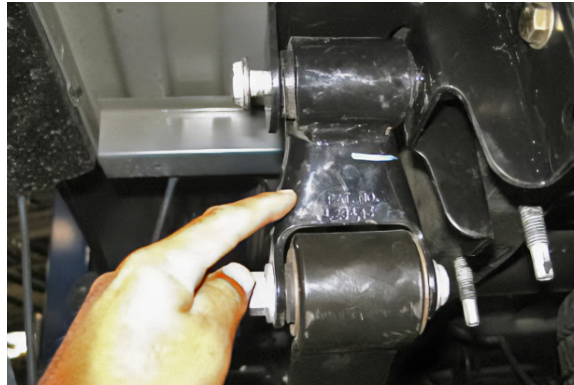

50. Place the Belltech axle saddles, part# 6525-020-99, on top of the leaf springs with the hole over the head of the spring center bolt. The offset hole at the bottom of the axle saddle MUST be oriented toward the front of the vehicle and the integrated bracket for the brake line and speed sensor wire will face the rear of the vehicle.

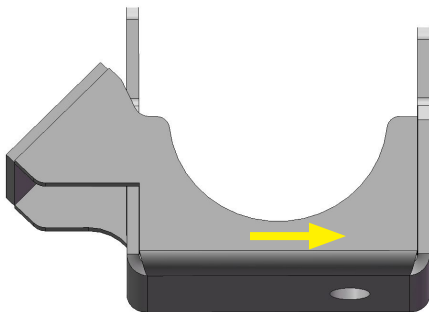

FLIP KIT INSTALLATION CONTINUED

51. Slowly, lower the axle onto the saddles. The ears should fit into the stock spring perches on the axle tubes. Make sure both ears on each saddle are located completely in the perches.

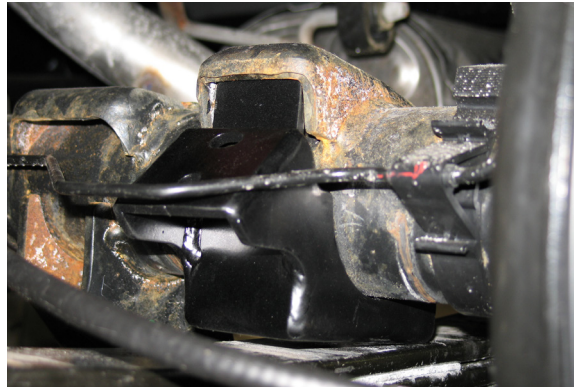

52. Place the supplied U-bolt spring pads, part# 6521-004-99, on top of the axle spring pads. Position the original U-bolts so the horizontal section sits inside the two bent flanges, securing them in place.

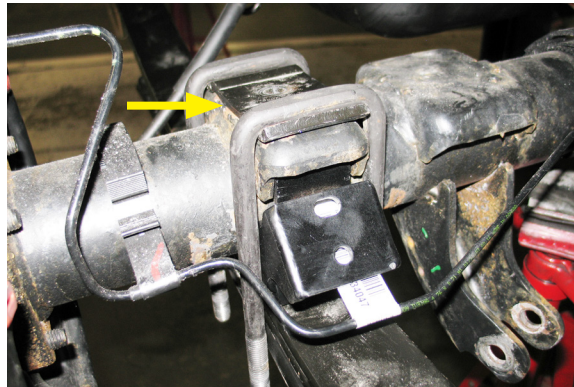

53. Position the supplied U-bolt plates, part# 6525-005-99, from below the leaf springs with the offset hole toward the front of the vehicle. This will allow the U-bolts to pass through the appropriate bolt holes. Fasten the U-bolts with the original nuts. Torque the nuts in a cross pattern using the following sequence: First Pass: 59 ft lbs., Second Pass: Loosen 180 degrees, Third Pass: 59 ft lbs., Final Pass: 120–140 degrees

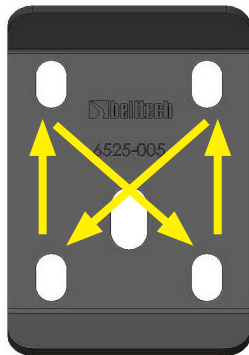

Technician warning:

The axle saddles have been designed to properly position the rear axle pinion shaft relative to the driveline. In combination with the driveline adjustments performed, driveline vibration should be eliminated. If driveline vibration *is* experienced after the installation, take the vehicle to a driveline service shop immediately for angle inspection and necessary adjustments. **DO NOT** drive the vehicle if it exhibits extreme driveline vibration as U-joint wear may occur. Ensure the U-joints are lubricated if deemed necessary.

FLIP KIT INSTALLATION CONTINUED

54. Press the speed sensor wire clip into the upper hole in the integrated saddle bracket. Fasten the brake line onto the lower hole on the bracket with the supplied M8 - 1.25 x 20 mm bolts, M8 flange nuts, and 3/8" washers. Torque to 16 ft lbs.

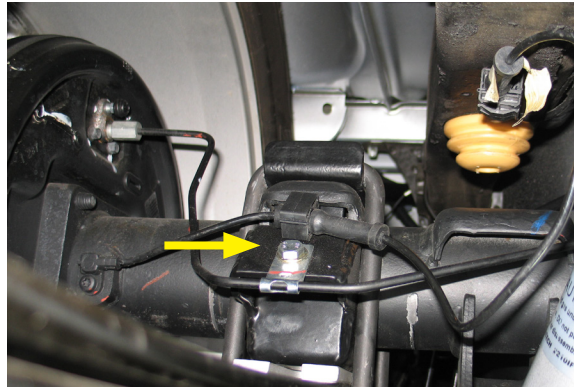

55. Fasten the supplied Belltech bump stops onto the chassis where the new holes were drilled and tapped.



56. Mount the rear shocks with the original hardware. Torque the upper and lower bolts to 70 ft lbs.



Technician note:

We suggest using Belltech Street Performance or Nitro Drop 2 shocks to achieve proper suspension travel with a reduced extended and compressed lengths shock.



FLIP KIT INSTALLATION CONTINUED

57. Raise the fuel tank into its original position. Ensure the rubber fuel neck is repositioned in its original location and no other hoses or lines are pinched/damaged.
58. Fasten the fuel nozzle intake onto the fuel door with the original bolts. Torque to 20 *in lbs*.
59. Attach the fuel tank straps to their original positions. One end hooked in and the other fastened with the original bolts. Torque the bolts to 30 ft lbs.
60. Attach the protective shield in its original position, fasten with the original bolts and torque to 13 ft lbs.
61. **2WD TRANSMISSION SPACER INSTALLATION** - For 2WD models, a transmission spacer is supplied to correct a small driveline vibration. The spacer will be installed between the transmission and the rubber mount.
62. Remove the two 15 mm bolts from the mount to the transmission. Use a floor jack to lift the transmission and place the spacer over the rubber mount, aligned with the bolt holes. Fasten with the supplied the supplied M10 - 1.5 x 35 mm bolts through the mount, spacer, and transmission. Torque to 49 ft lbs.

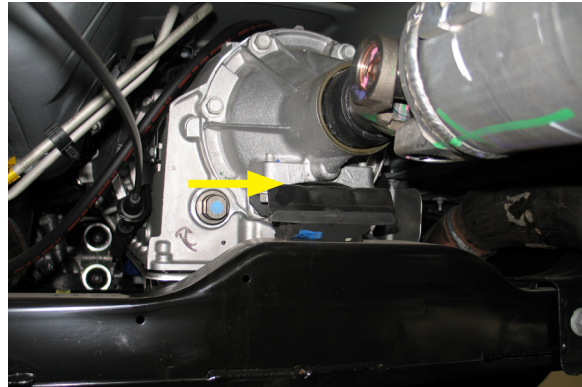
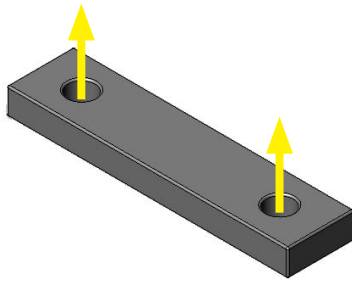

63. **4WD TRANSMISSION SPACER INSTALLATION** - For 4WD models, transmission spacer tubes are supplied. The spacers will be installed between the transmission and the rubber mount.
64. Remove the bolts to detach the transfer case shield from the crossmember.

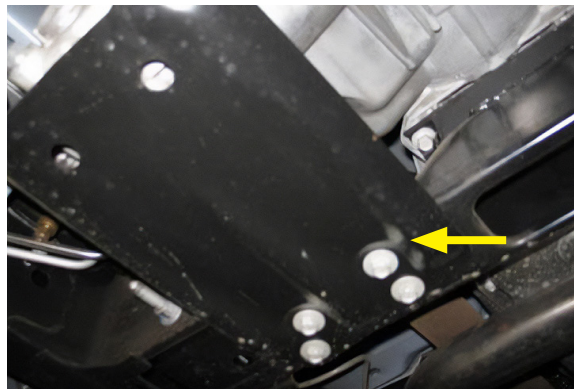

65. Remove the two 15 mm nuts holding the transmission mount to the crossmember.

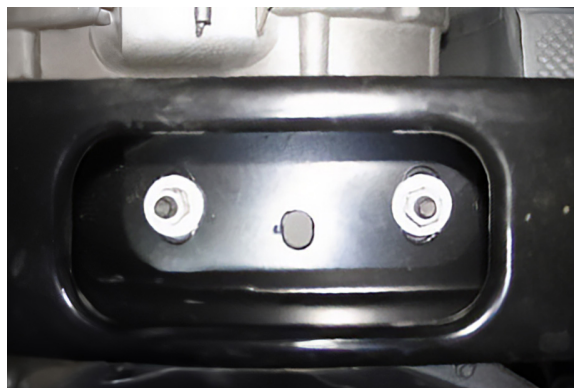

FLIP KIT INSTALLATION CONTINUED

66. Place a floor jack under the transfer case and raise the transmission 1" to gain access to the rubber mount bolts.

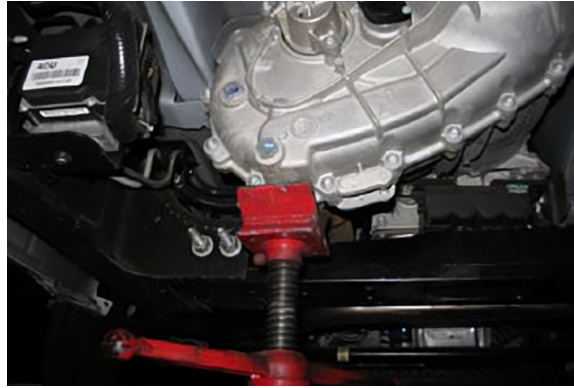

67. Remove the two 15 mm bolts from the mount to the transmission to separate the rubber mount.



68. Place two of the supplied transmission spacers tubes over each bolt hole. Ensure they are aligned with the bolt holes on the mount and transmission.



69. Fasten the mount, spacers, and transmission with the supplied M10 - 1.5 x 50 mm bolts and 7/16" washers.

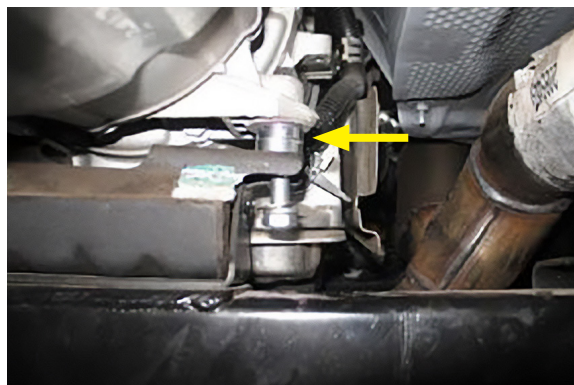

FLIP KIT INSTALLATION CONTINUED

70. Lower the transfer case to attach the transmission mount to the crossmember. Fasten with the original nuts and to torque to 41 ft lbs.
71. Torque the new M10 bolts through the mount, spacers, and transmission to 49 ft lbs.
72. Attach the transfer case shield to the crossmember and fasten with the original bolts.
73. Place the trailer hitch onto the chassis and fasten with the original bolts. Torque the bolts to 92 ft lbs.



74. Connect the hitch wiring plug into its original position and place the spare tire into the original position.



75. Mount the wheels and tighten the lug nuts.
76. Lift the vehicle and remove the support stands.
77. Carefully lower the vehicle onto the flat ground.
78. Torque the front leaf spring bolts to 125 ft lbs. plus 48 degrees and the rear shackle nuts to 85 ft lbs. plus 90 degrees

FINALIZING THE INSTALLATION

79. Torque the lug nuts to 140 ft lbs.
80. Check that all components and fasteners have been properly installed and torqued.
81. Read and perform all tasks in the “Before Driving Your Vehicle” section of page 1 of your instructions.

THANK YOU FOR CHOOSING BELLTECH.

You are now a part of the Belltech family and we are eager to catch a glimpse of your newly modified vehicle. Give us a shout out and let us know how much you love our product. Don't forget, we offer other Belltech related merchandise for you and your vehicle on our website www.belltech.com

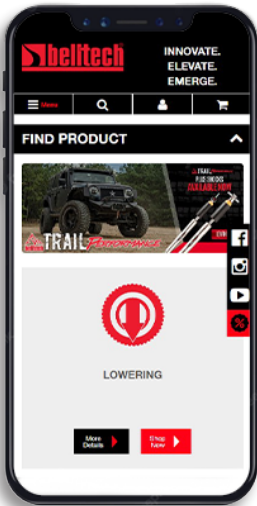

belltechsuspension



Belltech Suspension



@belltechsuspension



@belltechsuspension

If you have any questions, concerns, or warranty related issues regarding your Belltech product, please call or email our experienced customer service specialists.

Belltech Customer Support:

Phone: 1-800-445-3767

Email: info@belltech.com

KIT CONTENTS



Flip Kit		
Part number	Description	Qty
6519-010-99	REAR LEAF HANGER	2
6525-005-99	U-BOLT PLATE	2
6525-020-99	AXLE SADDLE	2
6521-004-99	U-BOLT SPRING PAD	2
6521-777	HARDWARE KIT	1
6521-774	HARDWARE KIT	1

Hardware Kit (6521-777)		
Part number	Description	Qty
110303	7/16"-20 STOVER LOCK NUT	6
112280	M8-1.25 FLANGE NUT	2
110645	7/16" WASHER	12
110625	3/8" WASHER	2
112002	M8 - 1.25 X 20 MM BOLT	2
112026	M10 - 1.5 X 35 MM BOLT	2
110650	7/16"-20 X 1-1/4" BOLT	6
6521-003-95	TRANSMISSION SPACER	1
5922-001	BUMP STOP	2

Hardware Kit (6521-774)		
Part number	Description	Qty
112532	7/16" SPLIT LOCK WASHER	2
110645	7/16" WASHER	2
111053	M10 - 1.5 X 50 MM BOLT	2
2005-007-95	TRANSMISSION SPACER TUBE	4



KW automotive North America, Inc.

300 W. Pontiac Way

Clovis, CA 93612

Phone: +1-559-875-0222

Toll Free: 1-800-445-3767

belltech.com