

## Long Travel Billet Uniball Upper Arm Instructions

Toyota Tundra 2022-2025

Always inspect your suspension after off-roading and at your routine service intervals. Use of products sold by Camburg Engineering is at the consumer's own risk. Proper installation and proper use of all products must be followed for optimal safety and performance. Installing most suspension products will raise the center of gravity of the vehicle and can increase the susceptibility to a rollover and alter the handling characteristics. Camburg Engineering products may void aspects of the vehicles warranty. Camburg Engineering reserves the right to change the design, material or specifications of any product without assuming any obligation to modify any product previously manufactured and without prior notice. Every effort has been made to avoid printing errors and specifications. By purchasing, installing and/or using these products you are accepting these stated conditions and accept all liability and responsibility.



Warranty Information  
Scan or Click QR Code

### Parts Supplied

QTY	DESCRIPTION	ID
4	FK 3/4" X 7/8" RHT Heim Joints	3
4	7/8-14 RHT Steel Jam Nuts	4
4	3/8-24 x 1.25" SHCS Allen Bolts	8
8	3/8" AN960 Round Washers	9
4	3/8-24 MS21042 Flanged Nuts	10
4	Heim Spacers (long   inner)	6
4	Heim Spacers (short   outer)	5
2	M16 x 1.50 Nyloc Nuts	7
4	Stainless Rubber Insulated Clamps	13
4	10-32 x 3/8" BHCS Allen Screws	11
8	#10 Stainless Washers	12
2	9/16" Upper Domed Uniball Spacers	15
2	9/16" Tapered Uniball Spindle Adapters	16
2	9/16-18 x 5" 12pt Bolts	14
2	1.50" OD x 9/16" ID x 3/16" Washers	17
2	9/16-18 Stover Lock Nuts	18
2	Uniball Cover Caps (press-on)	19
4	Uniball Cover Cap O-rings	20
1	#30 x 10" Fishing Line (for cap install only)	

\* REFER TO EXPLODED CAD DRAWING ON \*  
\* OTHER SIDE FOR PARTS REFERENCE NUMBERS \*

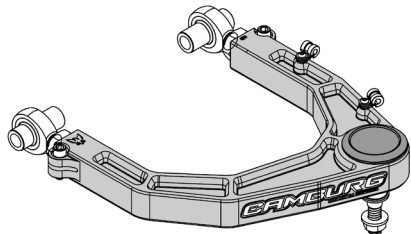

Please follow all instructions. If you are not installing these yourself have a qualified shop do so. These arms are designed specifically for our long travel kit and are to be used with stock OEM spindles or Camburg performance spindles. Make sure to check the parts list to make sure you have every component prior to starting. Camburg Engineering has made every attempt to insure you receive the highest quality components in the most complete manner. This is a guide to help you through the process with recommended torque specs. It's your responsibility to ensure parts are being installed correctly using the correct tools and procedures. We recommend reviewing a service manual for more details.

### Tools & Supplies Required

Eye Protection | Jack | Jack Stands | Needle Nose Pliers | Deburring Tool  
2-3 lb. Mini Sledge Hammer | Rubber Mallet | 19mm Socket  
22mm Socket & Wrench | 24mm Socket | 1-1/4" Open-end Wrench  
7/16" Socket | 9/16" 12pt Socket | 7/8" Socket | 5/32" Allen Wrench  
5/16" Allen Wrench | Torque Wrench | Brake cleaner | Anti-seize  
Grease | Red Loctite | Blue Painters Tape

### 1.0 Setup

Park the vehicle on level ground and set the parking brake and chock both rear wheels. Jack up the front end from the chassis until the front tires are off the ground. Place jack stands under the front frame rails and set down. Make sure the vehicle is supported correctly and the front tires are still off the ground. Place the jack under the driver side lower arm and raise the tire 1/2", then remove the wheel while keeping jack under lower a-arm to support the suspension. Read these instructions start to finish before moving forward and review diagrams.

### 2.0 Removal

Remove the ABS speed sensor wire from the sheet metal bracket on the stock upper arm, being very careful not to damage the wire. Using needle nose pliers, remove the cotter pin from the upper ball-joint at the spindle. Using a 19mm socket, loosen the castle nut but do not fully remove. With a mini sledge hammer strike the top of the spindle numerous times to release the ball-joint tapered stud. This can be a little difficult since it's a press fit, heating up the spindle to get it to expand will help if need be. Once the ball joint releases from the spindle, then remove the castle nut. Disconnect the arm from the spindle. Make sure to position & support the spindle so that it doesn't pull on the brake line and on 4wd models that it doesn't pull out the inner CV or strain the CV boots and axles. Using a 22mm socket & wrench, loosen and remove the OEM upper arm bolt. Remove the stock upper arm. You will not re-use the original large washers or nut.

### 3.0 Pre-installation

We recommend putting blue painters tape on the billet arms for protection during installation. Thread the 7/8" jam nuts onto the heims then apply anti-seize compound on the exposed threads. Thread the heims into the upper arm so the heim is vertical and the jam nut makes contact with the arm and you have 3 threads exposed past the nut.

Install the 3/8" allen heim pinch bolts into the arm. With a drop of red loctite on the nut, tighten and torque to 20-22 ft/lbs. Use a 1-1/4" open-end wrench to fully tighten the jam nut using another wrench to hold the heim vertical (perpendicular to the arm) so it doesn't rotate.

Now install the heim pivot spacers, first coating the surface that slips into the heim with anti-seize. The longer/thicker spacers go on the insides and the shorter/thinner spacers go on the outsides. See diagram for reference.

Using a countersink bit or deburring scraper tool, slightly chamfer the top-hole edge of the ball-joint taper in the spindle/knuckle. This will allow the spacer to fully seat when tightened and eliminate possible stress risers. Then inspect and clean the tapered hole. See diagram for reference.

### 4.0 Installation

Install the driver side Camburg upper arm to the frame using the existing OEM M16 bolt. To insure you're installing the correct arm, the longer a-arm leg is towards the front of the vehicle along with the Camburg logo with the threaded holes for the ABS clamps towards the rear. With the bolt pushed all the way through clean the threads using brake cleaner and install the supplied nyloc nut with red loctite. Using a 22mm wrench and 24mm socket, torque to 120 ft/lbs. Cycle the arm up and down to make sure there are no clearance issues. See diagram for reference.

Apply anti-seize to the uniball spacer surfaces shaded gray in the diagram. Insert the tapered lower uniball spacer into the uniball. Then install the upper spacer into the top of the uniball making sure both spacers are fully seated. If not damage will occur in the following steps. Install the 9/16" 12pt bolt through the spacers and uniball and attach the upper arm to the spindle by swinging it down to the spindle with some finesse. You may need to jack up the lower arm and move the uniball joint. The tapered spacer should sit almost flush with the top of the spindle/knuckle before tightening. Make sure the lower spacer did not pull out slightly from the uniball or damage will occur as the spacer can get caught on the bearing race. Install the 1.50" OD large washer and stover lock nut with a small amount of red loctite onto clean threads. Using a 9/16" 12pt socket and 7/8" socket, torque to 120-125 ft/lbs. Don't over-tighten or use an impact gun. See diagram for reference.

Using the supplied 10-32 hardware and rubber clamps, attach the ABS speed sensor wire to the backside of the upper arm using a 5/32" allen wrench and a drop of blue loctite. Get this hand tight only and do not over-tighten. Make sure to route the wire so that it has proper clearances and slack.

Lastly install the cap by first installing one of the supplied o-rings into the caps lower groove. Then apply a small amount of grease to the inside of the top of the cup. Use the supplied 30# fishing line and insert 2" of it into the upper arm cup This will be used to release the trapped air as the cap is pressed on. Position and center the cap with the Camburg logo in your desired position. Cover the cap with a rag to protect the finish and use a rubber mallet to tap the cover in if not by hand. Make sure to apply even pressure so that it presses in straight. When the cap is fully seated and you hear the air escape, pull the fishing line out and make sure the cap is tight to the cup. Twist the cap a few degrees to the right and left to help seat the cap and o-ring. Then install another o-ring between the cap and the arm. This will allow you to easily remove the cap by removing the o-ring and having a recess to grasp by hand or with a small plastic tool. Periodically check the caps to make sure they are fully seated after off-road use and remove temporarily after any pressure washing for moisture to dissipate.

**Repeat steps 1 through 4 to install passenger side arm**

**5.0 Alignment**

You will need to have your vehicle aligned by a qualified shop. Additional caster is built into the Camburg arms to correct alignment issues that are inherent with lifting the vehicle. Have your alignment shop increase positive caster, then set camber and toe to factory OEM specifications. Having an increase in caster helps with straight line stability and cornering precision for performance driving on and off-road.

**6.0 Maintenance & Care**

Use mild soap & water to clean the anodized aluminum surfaces, using chemicals can stain/dis-color the finish. Uniballs and heims are precision parts with tight tolerances which can lead to occasional noise when they become dirty. Occasionally wipe off the heims and underside of the uniball with a clean rag to remove road grime and dirt. Cleaning and lubricating them with WD-40 or a PTFE dry film lube like Super Lube can minimize any noise from stiction. Do not use harsh chemicals or grease/oils that attract dirt to clean & lube as it will damage and wear the internal teflon (PTFE) liner. You will need to occasionally remove the uniball cover to clean the top-side of the uniball.

Neglecting care and upkeep will wear parts out faster.

Inspect and re-torque all hardware and components after the first 500 miles, inspect at your scheduled maintenance intervals and whenever using the vehicle off-road.

**Notes**

Recommended tire size: 35-39 in.  
 Recommended wheel size: 17-20 in.  
 Recommended wheel backspacing = 4.50-4.80 in.  
 Maximum wheel backspacing = 4.80 in.

Torque M16 nut to 120 ft/lbs. w/ red loctite

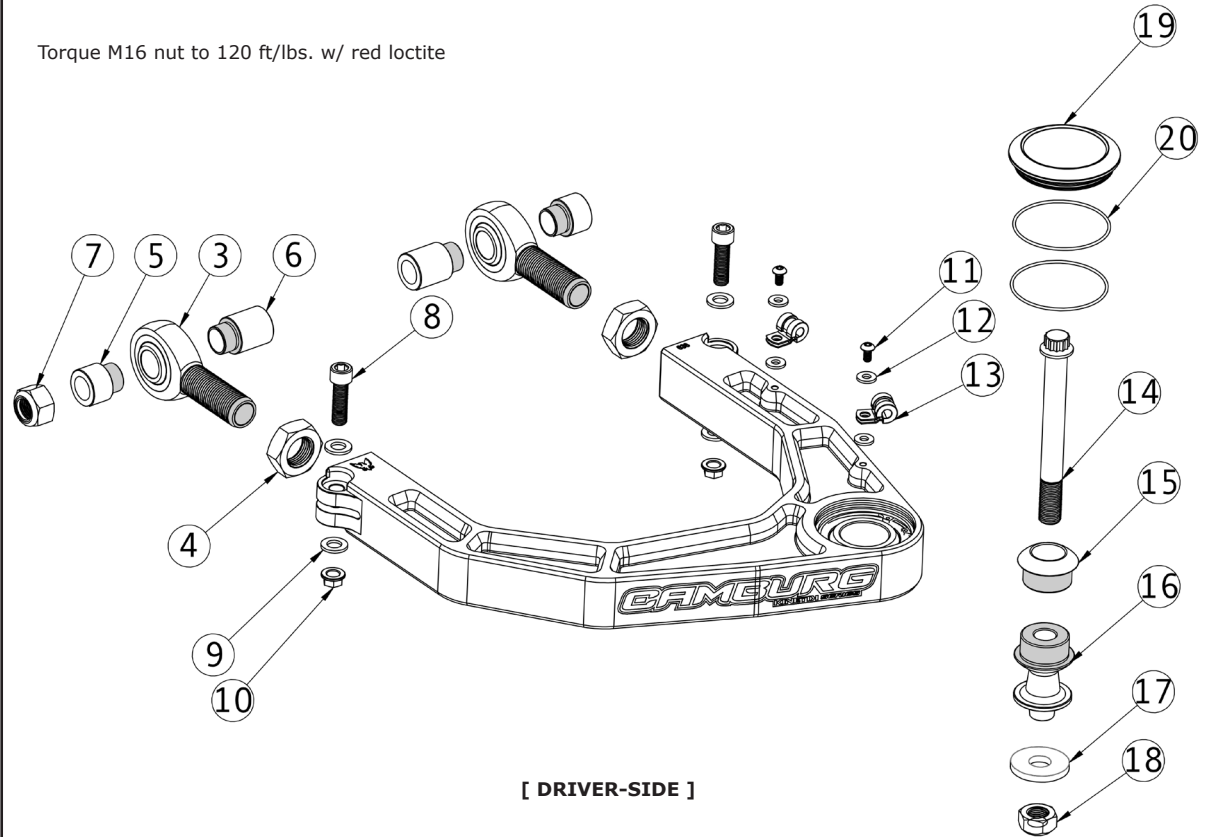

[ DRIVER-SIDE ]

Torque 9/16" nut to 120-125 ft/lbs. w/ red loctite

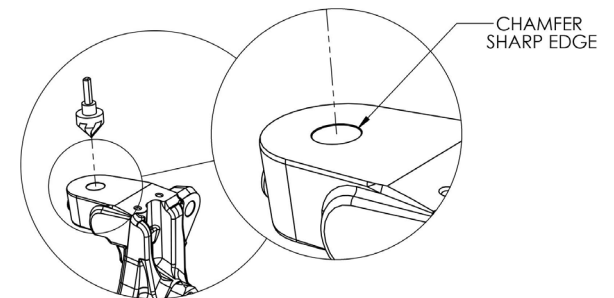
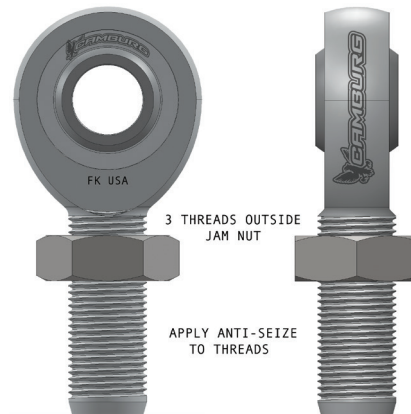



[12.21.25]

# TOYOTA TUNDRA 2022-2025 LONG-TRAVEL LOWER CONTROL ARMS PART# CAM-310217-K

[980132-2]

Always inspect your suspension after off-roading and at your routine service intervals. Use of products sold by Camburg Engineering is at the consumer's own risk. Proper installation and proper use of all products must be followed for optimal safety and performance. Installing most suspension products will raise the center of gravity of the vehicle and can increase the susceptibility to a rollover and alter the handling characteristics. Camburg Engineering products may void aspects of the vehicles warranty. Camburg Engineering reserves the right to change the design, material or specifications of any product without assuming any obligation to modify any product previously manufactured and without prior notice. Every effort has been made to avoid printing errors and specifications. By purchasing, installing and/or using these products you are accepting these stated conditions and accept all liability and responsibility.

If you are not installing these yourself have a qualified shop do so. These long-travel arms are designed to be used with stock OEM spindles or Camburg performance spindles. Check the parts list to make sure you have every component prior to installing. Camburg Engineering has made every attempt to insure you receive the highest quality components in the most complete manner. This is a guide to help you through the process with some recommended torque specs & notes. It's your responsibility to ensure parts are being installed correctly using the correct tools and procedures. For step-by-step instructions refer to a Toyota service/repair manual.

### Important Installation Notes:

- Aftermarket fiberglass fenders are required with this kit for the proper tire coverage and wheel well opening.
- Factory wheels will not work with this kit, you need aftermarket wheels with 4.50-4.80" of backspacing.
- The factory front sway bar will NOT be retained with this kit as it limits wheel travel and is designed for stock width control arms. We offer an optional sway bar kit designed for this kit with the proper geometry and spring rate.
- 4WD models require our longer axle shafts for the front OEM axle assemblies.
- Apply anti-seize to uniball spacer surfaces (shaded gray in diagram).
- Use RED loctite on all fasteners > 1/4" dia.
- Use BLUE loctite on 1/4" skid plate bolts.
- Inspect and re-torque all hardware and components after the first 500 miles, inspect at your scheduled maintenance intervals and whenever using the vehicle off-road.
- We recommend greasing the ball-joints 2-3 times per year or every 5-8k miles depending on use, higher frequency lubing may be required when used off-road and/or in wet/snow/mud conditions. We recommend using a high temp. lithium complex #2 synthetic grease.

ID	DESCRIPTION	QTY
	DRIVER SIDE LOWER ARM	1
	PASSENGER SIDE LOWER ARM	1
	DRIVER SIDE LOWER ARM SKID PLATE	1
	PASSENGER SIDE LOWER ARM SKID PLATE	1
3	LCA FRONT UNIBALL FRAME SPACERS (SHORT)	4
4	LCA REAR UNIBALL FRAME SPACERS (LONG)	4
5	GREASE ZERK FITTINGS	2
10	1/4" SAE GRADE 8 WASHERS	8
9	1/4-20 X 1" GRADE 8 HEX BOLTS	8
6	M16 WASHER	2
7	M16 X 1.5 CASTLE NUTS	2
8	COTTER PIN	2

### Recommended Torque Specs:

- Lower X-Joint Castle Nut = 125 ft/lbs.
- Lower Arm Frame Hardware = 210 ft/lbs.
- Lower Shock Hardware = 125 ft/lbs.
- 1/4" Skid Plate Bolts = 10-15 ft/lbs.

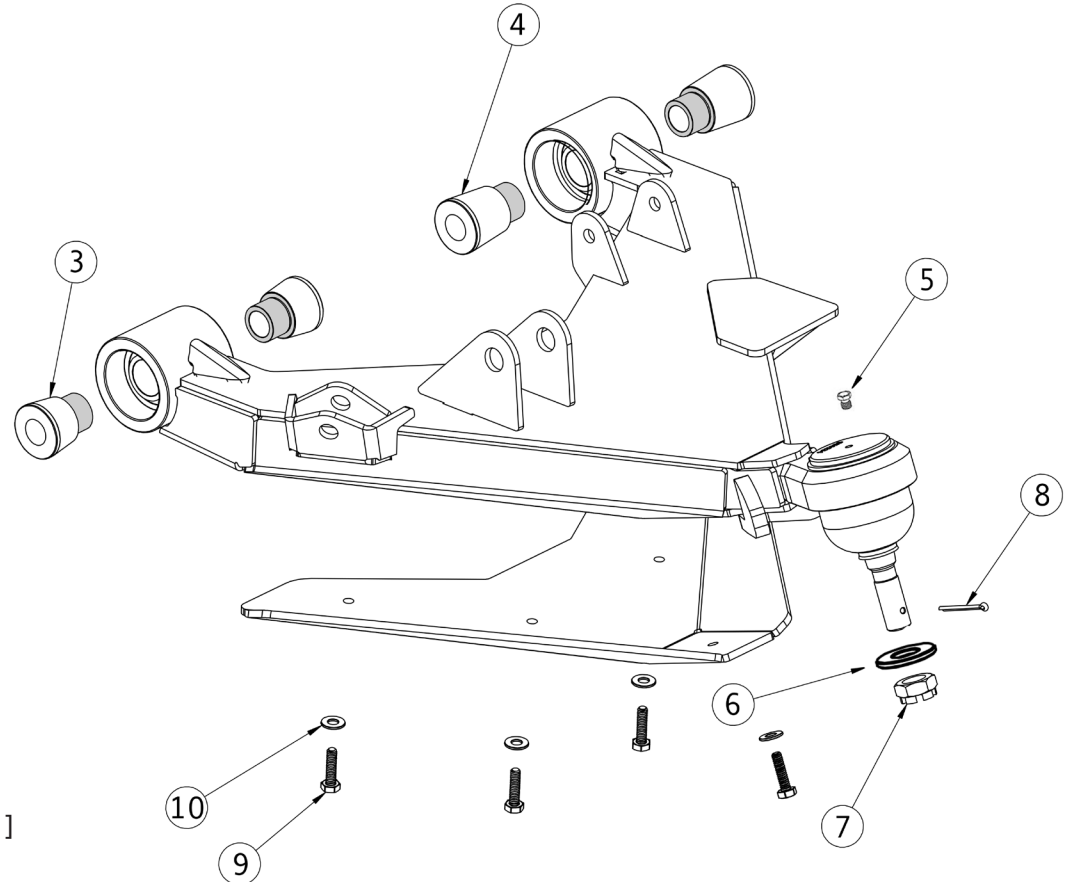
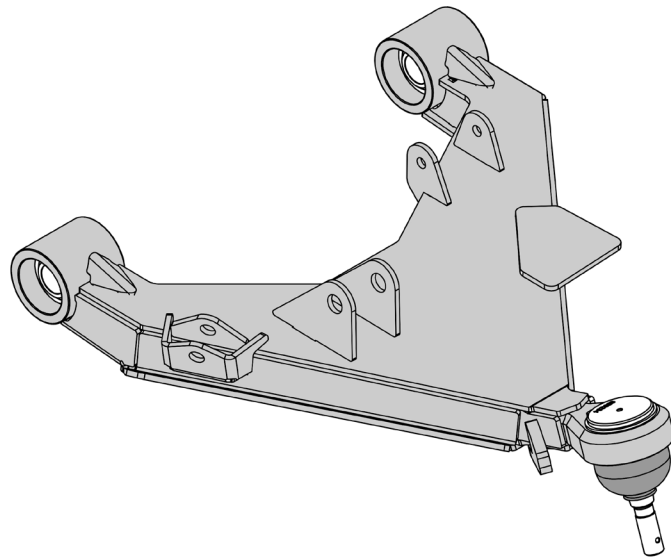

[DRIVER SIDE ARMS SHOWN]



Warranty Information  
Scan or Click QR Code



[12.20.25]

# TOYOTA TUNDRA 2022-2025 LONG-TRAVEL STEERING & MISC PARTS PART# CAM-310217-K

[980132-3]

Always inspect your suspension after off-roading and at your routine service intervals. Use of products sold by Camburg Engineering is at the consumer's own risk. Proper installation and proper use of all products must be followed for optimal safety and performance. Installing most suspension products will raise the center of gravity of the vehicle and can increase the susceptibility to a rollover and alter the handling characteristics. Camburg Engineering products may void aspects of the vehicles warranty. Camburg Engineering reserves the right to change the design, material or specifications of any product without assuming any obligation to modify any product previously manufactured and without prior notice. Every effort has been made to avoid printing errors and specifications. By purchasing, installing and/or using these products you are accepting these stated conditions and accept all liability and responsibility.

If you are not installing these yourself have a qualified shop do so. Check the parts list to make sure you have every component prior to installing. Camburg Engineering has made every attempt to insure you receive the highest quality components in the most complete manner. This is a guide to help you through the process with some recommended torque specs & notes. It's your responsibility to ensure parts are being installed correctly using the correct tools and procedures. For step-by-step instructions refer to a Ford service/repair manual.

ID	DESCRIPTION	QTY
1	M18 x 1.5 STEERING EXTENSIONS	2

### Important Installation Notes:

- Fully thread steering extensions into OEM outer tie rod ends.
- Use RED loctite on all fasteners > 1/4" dia.
- Use BLUE loctite on all fasteners < 1/4" dia.
- Inspect and re-torque all hardware and components after the first 500 miles, inspect at your scheduled maintenance intervals and whenever using the vehicle off-road.

### Recommended Torque Specs:

- Outer Tie Rod End Nut = 90 ft/lbs.

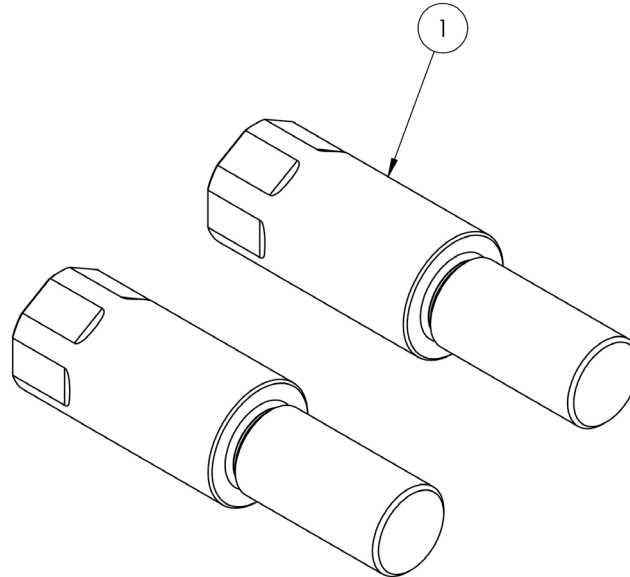

Warranty Information

Scan or Click QR Code