

## KINETIK Billet X-Joint XL Upper Arm Instructions

Chevy/GMC Silverado 1500 2wd/4wd 2019-2025

Always inspect your suspension after off-roading and at your routine service intervals. Use of products sold by Camburg Engineering is at the consumer's own risk. Proper installation and proper use of all products must be followed for optimal safety and performance. Installing most suspension products will raise the center of gravity of the vehicle and can increase the susceptibility to a rollover and alter the handling characteristics. Camburg Engineering products may void aspects of the vehicles warranty. Camburg Engineering reserves the right to change the design, material or specifications of any product without assuming any obligation to modify any product previously manufactured and without prior notice. Every effort has been made to avoid printing errors and specifications. By purchasing, installing and/or using these products you are accepting these stated conditions and accept all liability and responsibility.



Warranty Information  
Scan or Click QR Code

### Parts Supplied

QTY	Description	ID
4	FK 3/4" X 7/8" RHT Heim Joints	3
4	7/8-14 RHT Steel Jam Nuts	4
4	3/8-24 x 1.25" SHCS Allen Bolts	7
8	3/8" AN960 Round Washers	8
4	3/8-24 MS21042 Flanged Nuts	9
8	Frame Pivot Heim Spacers	5
4	M14 x 2.0 Flanged Nyloc Nuts	6
2	10-32 x 3/8" BHCS Allen Screws	12
4	#10 Stainless Washers	13
3	Stainless Rubber Insulated Clamps	14
2	Grease Zerk Fitting (straight)	10
2	M12 x 1.75 Flanged Nyloc Nuts	11
2	X-Joint Cover Caps (press-on)	15
4	X-Joint Cover Cap O-rings	16
1	#30 x 10" Fishing Line (for cap install only)	
4	Camburg 8.5" Stickers	

\* REFER TO EXPLODED CAD DRAWING ON \*  
\* OTHER SIDE FOR PARTS REFERENCE NUMBERS \*

**\*\* IMPORTANT \*\***  
**These are NOT compatible with vehicles equipped with electronic Adaptive Ride Control suspension.**



Thanks for purchasing a set of our KINETIK series billet upper arms for your vehicle. Please follow all instructions. If you are not installing these yourself have a qualified shop do so. These arms are designed for 1-3" of lift from coilovers and to be used with stock OEM spindles or Camburg performance spindles. These are NOT designed to be used with cheap spacer type lifts. Make sure to check the parts list to make sure you have every component prior to starting. Camburg Engineering has made every attempt to insure you receive the highest quality components in the most complete manner. This is a guide to help you through the process with recommended torque specs. It's your responsibility to ensure parts are being installed correctly using the correct tools and procedures. We recommend reviewing a service manual for more details.

### Tools & Supplies Required

Eye protection | Jack | Jack Stands | 21mm Socket & Wrench  
2-3 lb. Mini Sledge Hammer | Rubber Mallet | 1-1/4" Open-end Wrench  
7/16" Socket | 5/16" Allen Driver | 8mm Wrench | 18mm Socket  
1/8" Allen Wrench | Torque Wrench | Brake Cleaner | Grease  
Anti-seize | Red Loctite | Blue Painters Tape | Cut-off Wheel  
Vise Grip Pliers

### 1.0 Setup

Park the vehicle on level ground and set the parking brake and chock both rear wheels. Jack up the front end from the chassis until the front tires are off the ground. Place jack stands under the front frame rails and set down. Make sure the vehicle is supported correctly and the front tires are still off the ground. Place the jack under the driver side lower arm and raise the tire 1/2", then remove the wheel while keeping jack under lower a-arm to support the suspension. Read these instructions start to finish before moving forward and review diagrams.

### 2.0 Removal

Using a 10mm socket, remove the ABS line bracket from the top of the OEM upper arm and remove the line from the actual steel bracket. This will not be re-used. Then using a 18mm socket, loosen the nut from on the upper ball-joint where it connects to the spindle but do not fully remove. With a mini sledge hammer strike the top of the spindle numerous times to release the ball-joint tapered stud. This can be a little difficult since it's a press fit, heating up the spindle to get it to expand will help if need be. Once the ball joint releases from the spindle, then remove the nut. This will allow you to position the upper arm and spindle out of the way. Make sure to position & support the spindle so that it doesn't pull on the brake line and on 4wd models that it doesn't pull out the inner CV or strain the CV boots and axles. You will need to remove the coilover/strut to access the upper arm bolts at the frame. Refer to your coilover instructions or service manual for details. Once the coilover is removed, use a 21mm socket & wrench to loosen and remove the OEM upper arm bolts. Remove the stock upper arm. You'll then need to remove the small tab on the rear portion of the coil bucket. You can do this with a cut-off wheel or breaking the tab off with vise grip pliers. Touch up with black paint if needed. See diagram for reference.

### 3.0 Pre-Installation

We recommend putting blue painters tape on the billet arms for protection during installation. Thread the 7/8" jam nuts onto the heims then apply anti-seize compound on the exposed threads. Thread the heims into the upper arm so the heim is vertical and the jam nut makes contact with the arm and you have 3 threads exposed past the nut. Install the 3/8" allen heim pinch bolts into the arm. With a drop of red Loctite on the nut, tighten and torque to 20-22 ft/lbs. Use a 1-1/4" open-end wrench to fully tighten the jam nut using another wrench to hold the heim vertical (perpendicular to the arm) so it doesn't rotate. Now install the heim pivot spacers into the heims, first coating the surface that slips into the heim with anti-seize. See diagram for reference.

Using an 8mm socket, install the straight grease zerk fitting into the top of the X-Joint. Do not over tighten or cross thread.

### 4.0 Installation

Install the driver side Camburg upper arm into the frame using the original bolts in the same orientation as it was removed. To insure you're installing the correct arm, the longer a-arm leg is towards the front of the vehicle along with the Camburg logo. Clean the threads with brake cleaner and apply a little red loctite to the nut area. Using a 21mm wrench and 21mm socket, torque the supplied M14 nyloc nuts to 90 ft/lbs. Cycle the arm up and down to make sure there are no clearance issues. See diagram for reference. Re-install the coilover/strut.

Prior to installing the X-Joint stud into the spindle, inspect and clean the tapered hole in the spindle/knuckle. Swing down the upper arm so the X-Joint stud inserts into the spindle. You may need to jack up the lower arm and move the X-Joint stud. Install M12 nyloc nut with a small amount of red loctite onto clean threads. Using a 18mm socket, torque to 80 ft/lbs. Don't over-tighten or use an impact gun. See diagram for reference.

**IMPORTANT: Now you'll need to grease the X-Joint, if not damage will occur.** Using a hand grease gun with a high temp. lithium complex #2 synthetic grease, slowly pump grease into the joint through the zerk fitting making sure not to over grease or over pressurize. When you see the boot to begin to swell, that's a sign the X-Joint is fully greased.

Then attach the ABS wires to the upper arm using the supplied rubber insulated clamps and 10-32 hardware using a 1/8" allen wrench. The driver side uses two clamps and the passenger side only uses one clamp. See diagram for reference. Put a little grease on the threads and get hand tight only, do not over-tighten. Make sure to route the wires so that they have proper clearances and slack.

Lastly install the cap by first installing one of the supplied o-rings into the caps lower groove. Then apply a small amount of grease to the inside of the top of the cup. Use the supplied 30# fishing line and insert 2" of it into the upper arm cup This will be used to release the trapped air as the cap is pressed on. Position and center the cap with the Camburg logo in your desired position. Cover the cap with a rag to protect the finish and use a rubber mallet to tap the cover in if not by hand. Make sure to apply even pressure so that it presses in straight. When the cap is fully seated and you hear the air escape, pull the fishing line out and make sure the cap is tight to the cup. Twist the cap a few degrees to the right and left to help seat the cap and o-ring. Then install another o-ring between the cap and the arm. This will allow you to easily remove the cap by removing the o-ring and having a recess to grasp by hand or with a small plastic tool. Periodically check the caps to make sure they are fully seated after off-road use and remove temporarily after any pressure washing for moisture to dissipate.

**Repeat steps 1 through 4 to install passenger side arm**

**5.0 Alignment**

You will need to have your vehicle aligned by a qualified shop. Additional caster is built into the Camburg arms to correct alignment issues that are inherent with lifting the vehicle. Have your alignment shop increase positive caster, then set camber and toe to factory OEM specifications. Having an increase in caster helps with straight line stability and cornering precision for performance driving on and off-road.

**6.0 Maintenance & Care**

Use mild soap & water to clean the anodized aluminum surfaces, using chemicals can stain/dis-color the finish. Heims are precision parts with tight tolerances which can lead to occasional noise when they become dirty. Occasionally wipe off the heims with a clean rag to remove road grime and dirt. Cleaning and lubricating them with WD-40 or a PTFE dry film lube like Super Lube can minimize any noise from stiction. Do not use harsh chemicals or grease/oils that attract dirt to clean & lube as it will damage and wear the internal teflon (PTFE) liner. Neglecting care and upkeep will wear parts out faster.

We recommend greasing the X-Joints 2-3 times per year or every 5-8k miles depending on use with a high temp. lithium complex #2 synthetic grease.

Higher frequency lubing may be required when used off-road and/or in wet/snow/mud conditions.

Inspect and re-torque all hardware and components after the first 500 miles, inspect at your scheduled maintenance intervals and whenever using the vehicle off-road.

**Notes**

- Recommended tire size: 33-35 in.
- Recommended wheel size: 17-20 in.
- Recommended/Maximum wheel backspacing = 4.75 in.

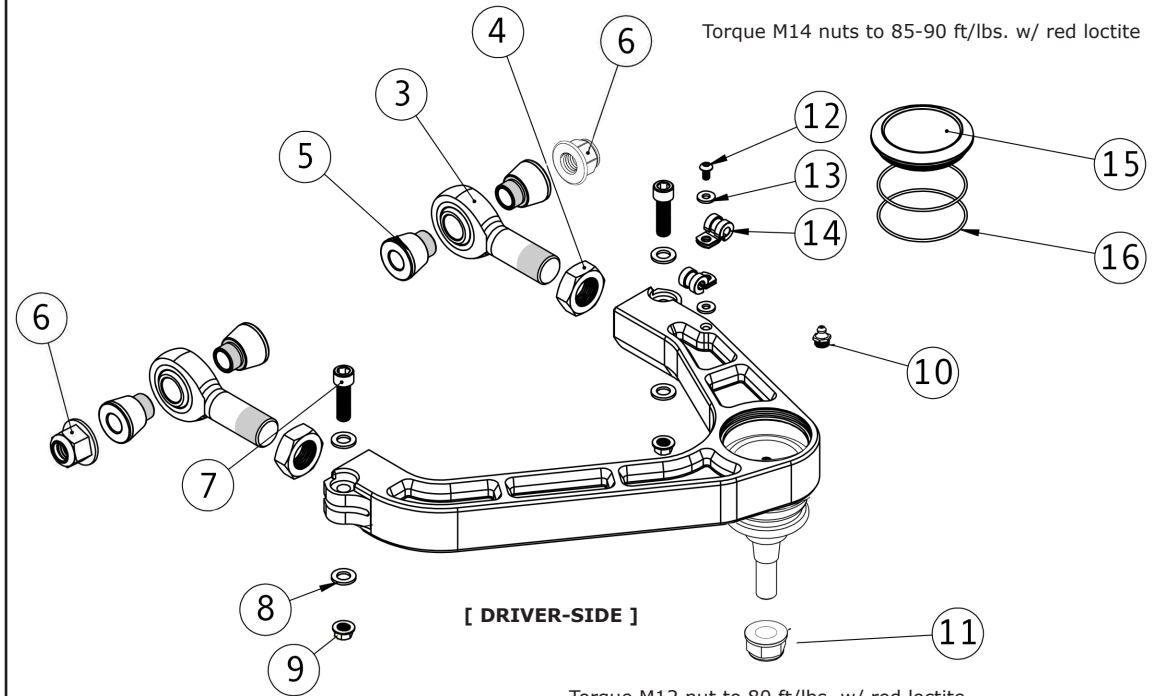

[ DRIVER-SIDE ]

Torque M12 nut to 80 ft/lbs. w/ red loctite

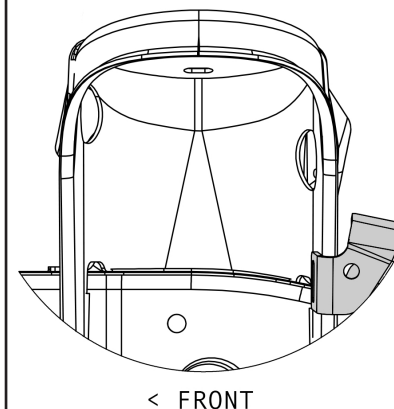

REMOVE

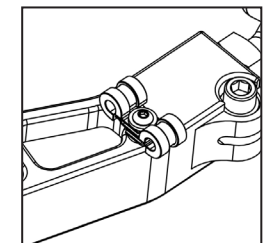
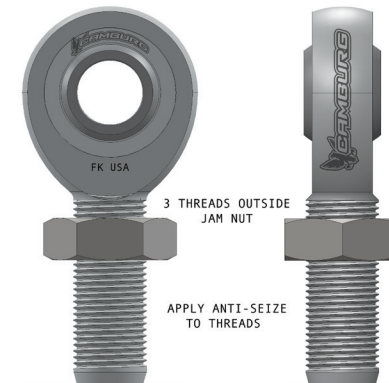

DRIVER SIDE

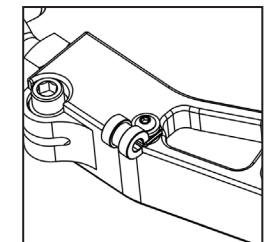

PASSENGER SIDE