



# Installation Instructions

Vehicle Application:  
Toyota Landcruiser FJ40 1964-1984  
Part Number 51464

[www.Bestop.com](http://www.Bestop.com) - We're here to help! Visit our web site and click on "Ask a Question". Click here for more [Jeep Accessories by Bestop](#).

**NOTE** Removing the hard top on vehicles built after 1975 removes the tailgate. This product is designed only to replace existing soft tops on vehicles with an existing tailgate or tailgate panel.

<b>INSTALLATION TIME</b>		<b>SKILL LEVEL</b>	
<b>3 Hours</b>		<b>3 - Moderately Difficult</b>	
<b>TOOLS</b>			
 Wrench 10 mm	 Adjustable Wrench	 Phillips Screwdriver	 Tape Measure
 Hammer	 50/50 Solution Alcohol/Water	 Power Drill 1/8", 5/32", 3/16" Bits	 Center Punch
 Pencil	 Scissors	 Safety Glasses	



**CAUTION** Safety glasses should be worn at all times while installing this product.

### Installation Tips

Before you begin installing this assembly, read all instructions thoroughly.

#### For a smooth fit:

For ease in installation, the product should be installed at temperatures above 72° F. Below this temperature, the fabric may contract an inch or more, making it difficult to fit to the vehicle. It is normal for fabric to contract and wrinkle when stored in the shipping carton. Within a few days after the installation, the fabric will relax and the wrinkles will disappear.

**WARNING** This product is designed primarily to enhance the appearance of the vehicle and to shield the occupants from ordinary weather conditions. Do not rely in any way on the components of this product to contain occupants within the vehicle, or to protect against injury or death in the event of an accident. This product will not protect the occupants from falling objects. Never operate the vehicle in excess of manufacturer's specifications.

#### WEAR SEAT BELTS AT ALL TIMES

Read and follow, precisely, all installation instructions provided when installing product. Failure to do so may result in a poor fit and could place occupants of the vehicle in a potentially dangerous situation.



# Parts List and Hardware Identification

Top Fabric Qty - 1

Bow Assembly - Right, Part Number 384.26P, Qty - 1

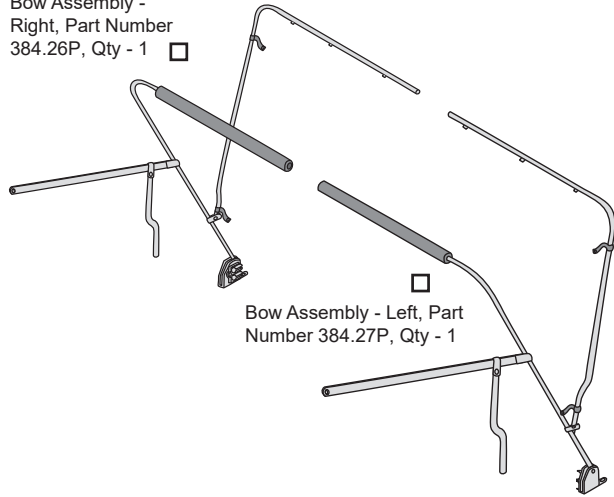

Bow Assembly - Left, Part Number 384.27P, Qty - 1

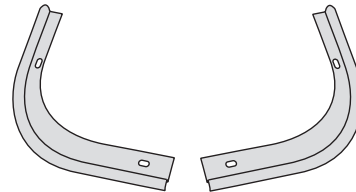

Rear Corner Retainer Kit Part Number 370.87P, Qty - 1



Bow Coupler, Part Number 244.73P, Qty - 2

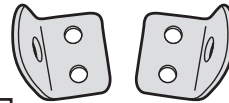

Horizontal Rod Bracket Kit, Part Number 13.85P, Qty - 1

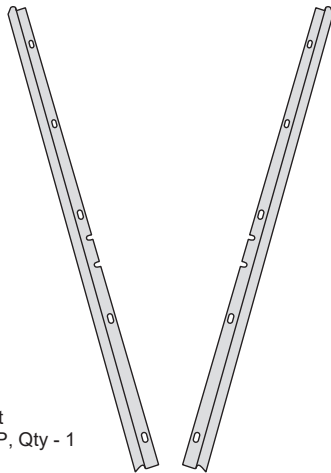

Side Belt Retainer Kit Part Number 370.86P, Qty - 1

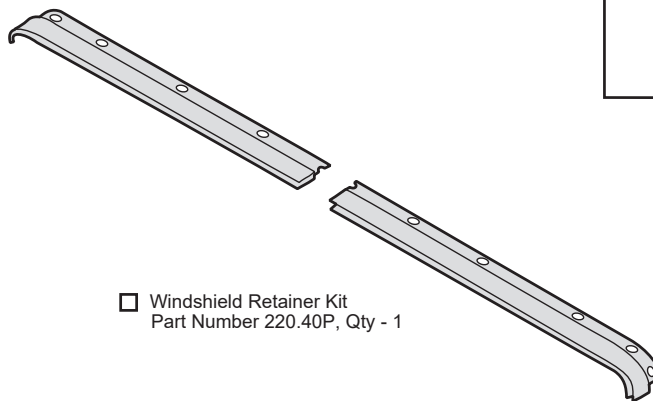

Windshield Retainer Kit Part Number 220.40P, Qty - 1

Hardware Kit Part Number 382.40P, Qty - 1

(Includes 13.85P Horizontal Rod Brackets)

#8 x 1/2" Pan Head Washer Screw - Black, Part Number 200.48, Qty - 9



#10 x 1/2" Pan Head Sheet Metal Screw, Part Number 1.92, Qty - 4

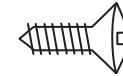
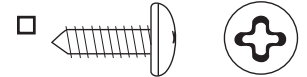

#10 x 1/2" Oval Head Screw, Part Number 155.49, Qty - 4

M6 Machine Screw, Part Number 322.41, Qty - 14

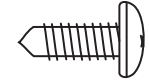
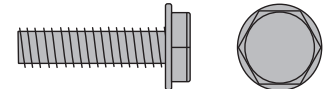

#14 Sheet Metal Screw, Part Number 243.51, Qty - 4

5/16 x 3/4" Hex Bolt, Part Number 116.03, Qty - 2

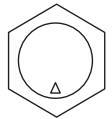
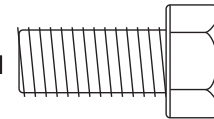

Wing Nut, Part Number 151.83, Qty - 2

Footman Loop, Part Number 272.29, Qty - 2

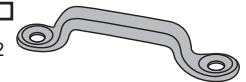

Not Shown:

Buckle Strap Part Number 243.61P Qty - 2  
1" Adhesive Hook Strip Part Number 14.71 Qty - 1



## 1 Windshield Adjustment

Measure and record the distance from the top inside edge of the windshield to the top outer edge of the vehicle body. Take the measurement from approximately six inches inside the vehicle's doors. Check to make sure that both sides measure equally. To install this top properly, this measurement must be 81".

Adjust your windshield by loosening the Windshield Clamps and adjusting the brackets. You may then lean the windshield forward or back as necessary. Use a shim to fix the windshield in place if it remains loose after you tighten the screws.

**NOTE** This is a very important step in the installation process. Improper windshield adjustment may result in a poor fit of the top.

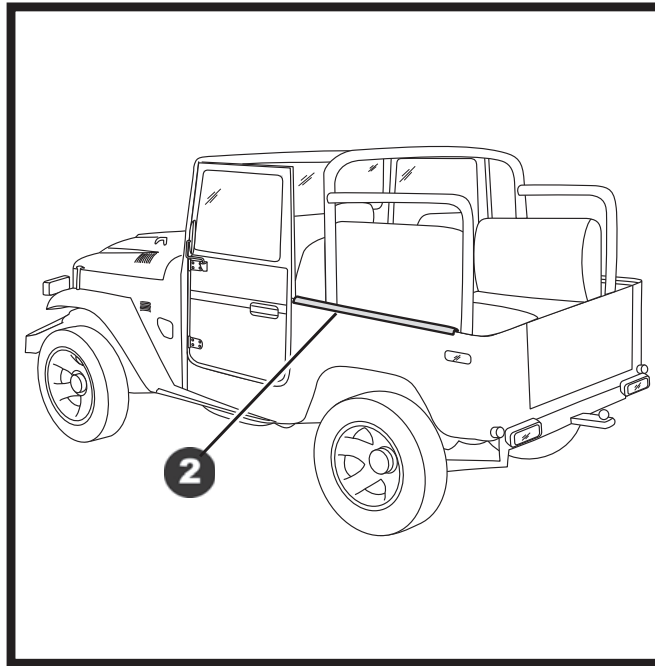

## 2 Install Side Belt Retainers

Orient the Side Belt Retainers on the vehicle with the flat ledge toward the inside and the notches toward the front. Align the slots in the retainers with the holes in the vehicle and install five M6 Machine Screws in each retainer.

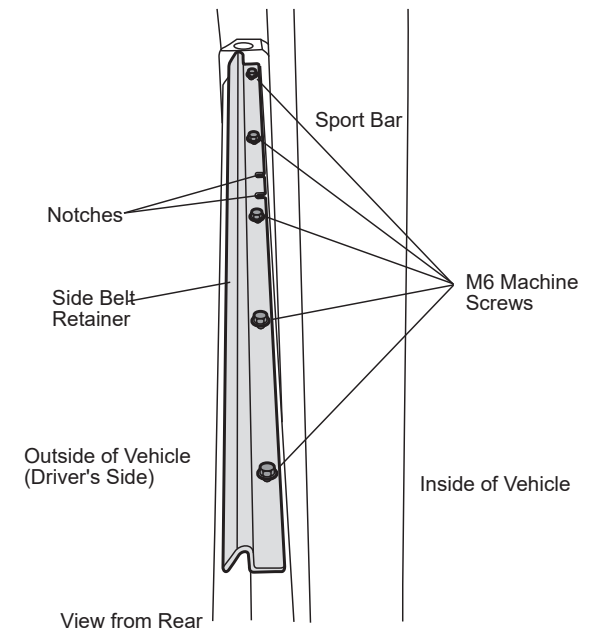
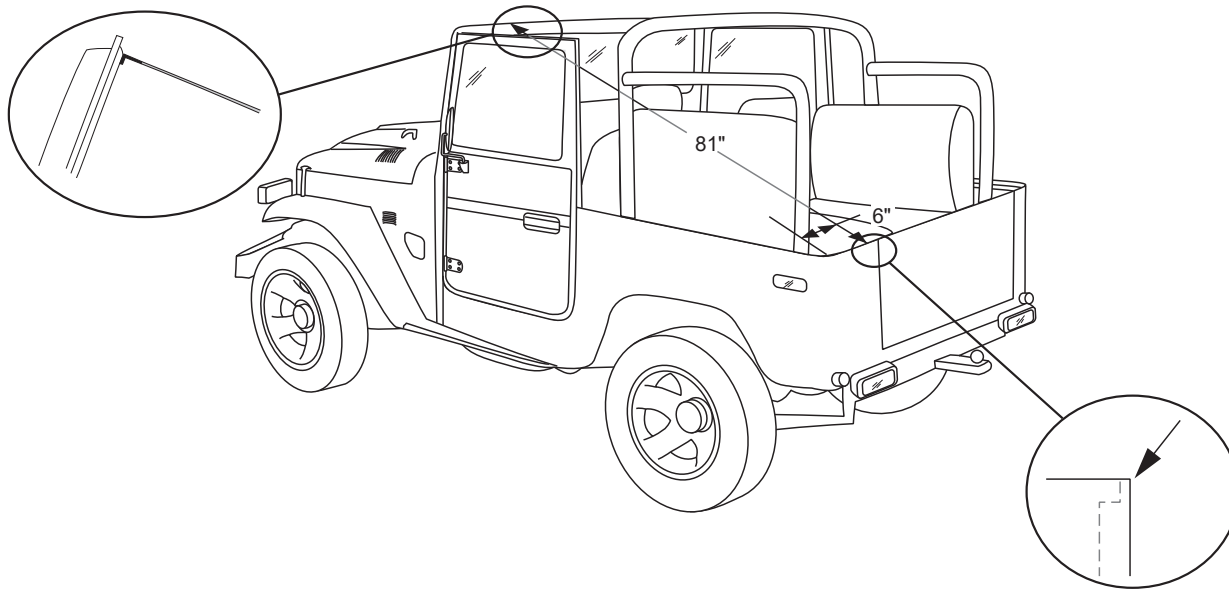

### 3 Install Rear Corner Retainers

Orient the Rear Corner Retainers on the vehicle with long leg to the front and the flat ledge to the inside of the vehicle. Make sure that they are tight against the flange, leaving approximately a 1/4" gap to the Side Belt Rail. Align the slots in the retainers with the holes in the vehicle and install two M6 Machine Screws in each retainer.

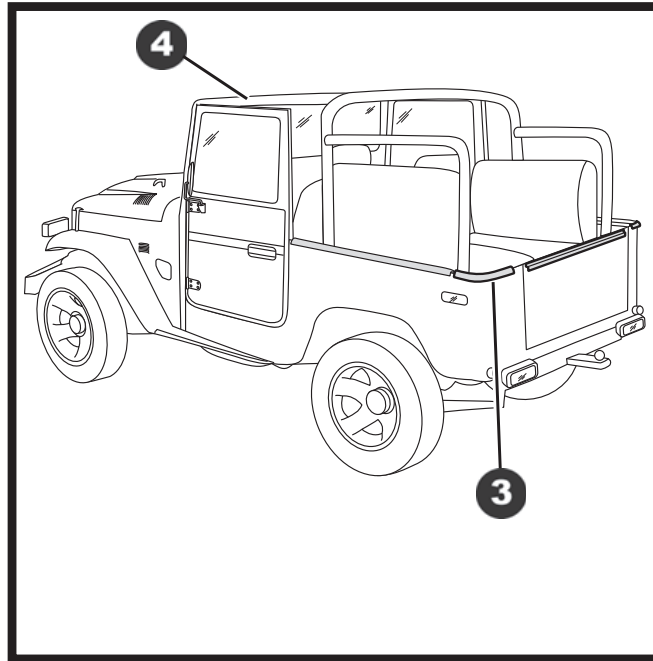
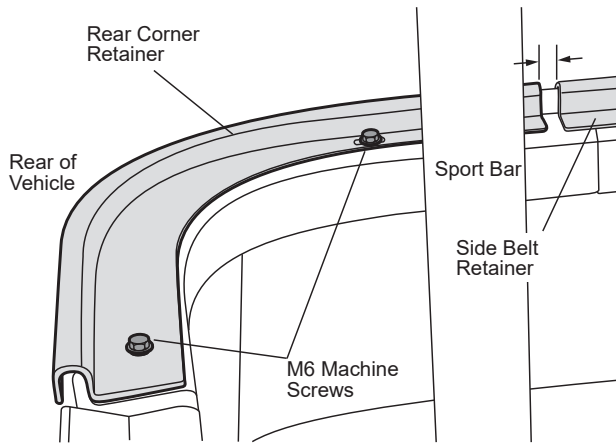

### CAUTION

A loose windshield retainer may allow the top to disengage from the windshield, causing damage to the top and possible injury to the occupants of the vehicle. Make certain that the windshield retainer is securely fastened to the windshield at the time of first installation. Check the tightness of the mounting screws every three months. (Do not over-tighten.)

### 4 Install Windshield Retainer

Orient the Windshield Retainers on top of the windshield frame with the channel toward the front and so that when they are butted up against each other they form a hole for a screw at the joint. Align them with the top lip of the windshield frame. Use the retainers as a template to mark, center punch and drill nine 1/8" holes (drill one 1/8" hole between the two halves of the retainer.) Install nine #8 x 1/2" Pan Head Washer Screws.

**NOTE** If your vehicle currently has a windshield retainer, it must be removed and replaced with the enclosed windshield retainer. There may be existing holes on some vehicles that may interfere with the holes in the new windshield retainers. If so, it may be necessary to drill the retainer holes off to one side. The curved ends of the retainers will hang over the windshield frame.

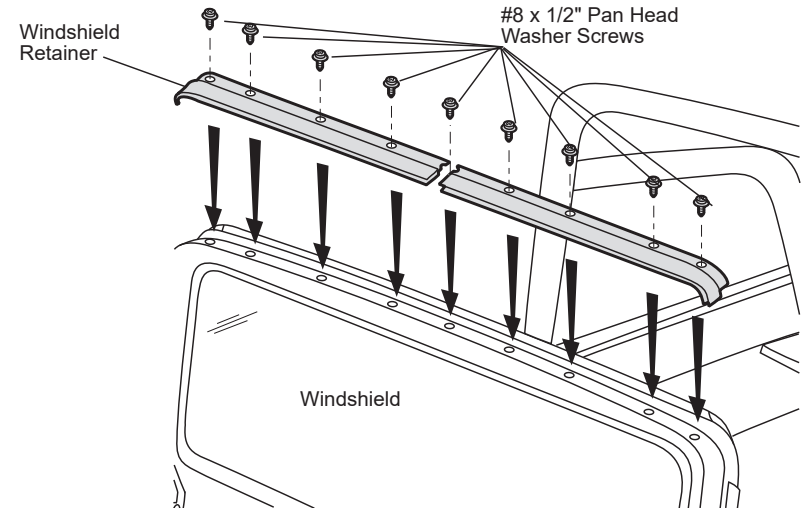



## 5 Install Horizontal Rod Brackets – Optional

If your vehicle is already equipped with brackets in the upper corners of the windshield, skip to Step Seven.

Position the Horizontal Rod Bracket in the upper corner of the windshield, flush with the edge of the frame. Use the bracket as a template to mark the location of the holes. Center punch and drill two 5/32" holes. Install two #10 x 1/2" Pan Head Sheet Metal Screws. Repeat this procedure for the other bracket.

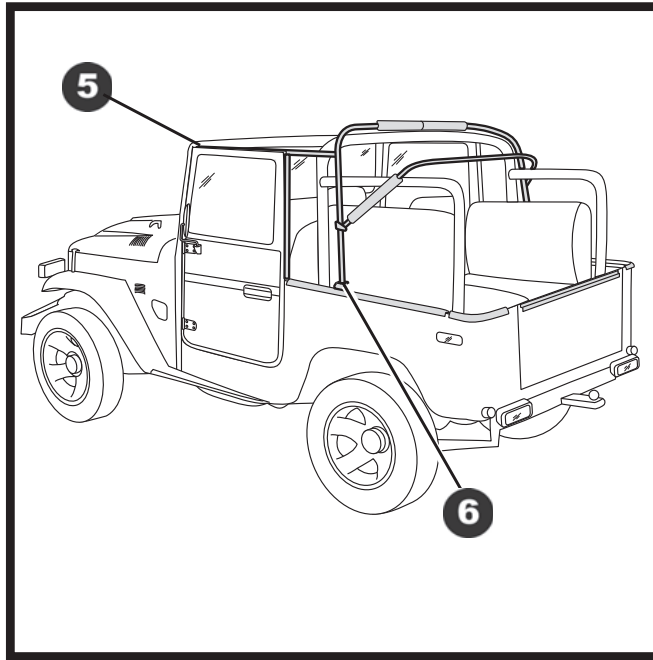
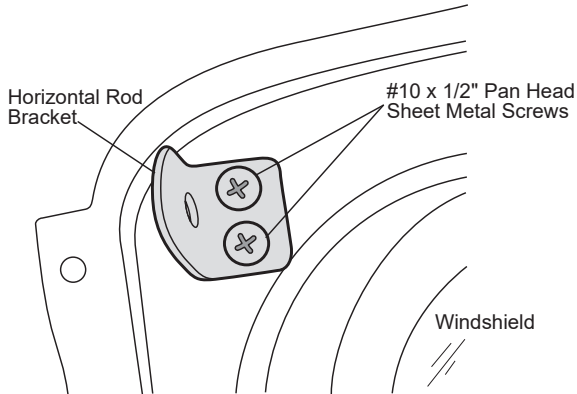

**NOTE** It may be necessary to remove any Sport Bar Padding.

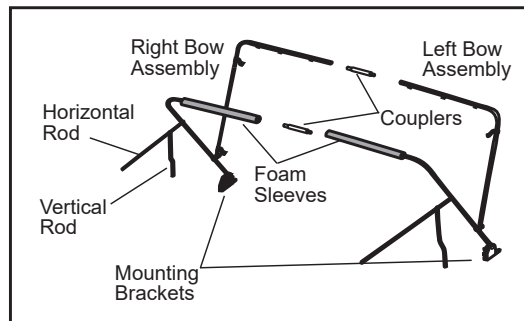

**! WARNING** Installation of the Bow Assemblies involves drilling in the top edge of the vehicle body. Check under the body edge at the marked locations. There may be wiring for the rear lights. If so, pull the wiring out of the way before drilling.

## 6 Install Bows

This step will require two people. Locate the left and right Bow Assemblies in the parts kit. Select one of the assemblies and lay it on the body. Center the holes of the Bow Assembly Mounting Bracket over the notches in the Side Belt Retainer. Use the front hole in the Bow Mounting Bracket as a template to mark, center punch and drill a 3/16" hole. Install a #14 Sheet Metal Screw. Lift up the Bow Assembly and use the rear hole in the Bow Assembly Mounting Bracket as a template to mark, center punch and drill a 3/16 inch hole for the rear of the bracket. Install a #14 Sheet Metal Screw in this location. Repeat this procedure on the opposite side of the vehicle. Lay the Bow Assemblies down onto the body and connect the Bow Halves together with the Bow Couplers. Slide the foam sleeves on the front bow to the center of the Bow Coupler on the front Bow Assembly.

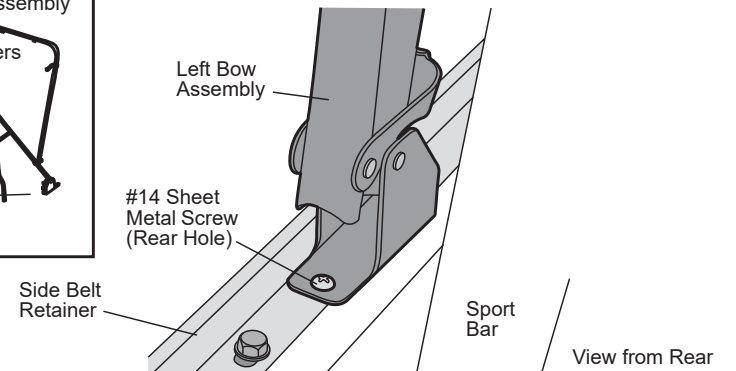



## 7 Install Vertical Rod

Rotate the bows forward and slide the end of the Vertical Rod into the hole in the vehicle body behind the door opening.

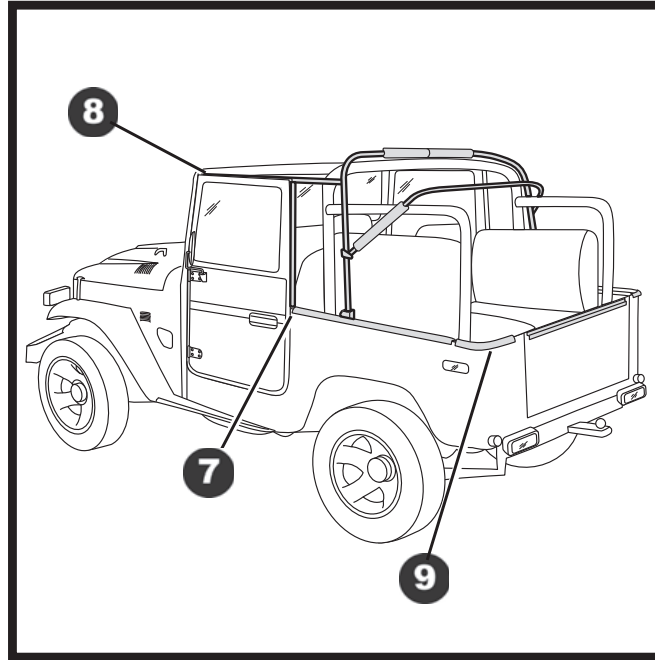
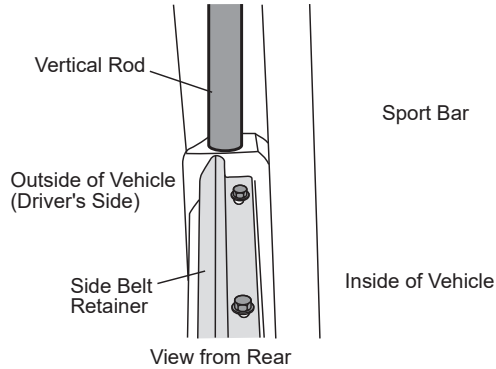

**! WARNING** Installation of the Bow Assemblies involves drilling in the top edge of the vehicle body. Check under the body edge at the marked locations. There may be wiring for the rear lights. If so, pull the wiring out of the way before drilling.

## 9 Install Footman Loop

Install the Footman Loops on the top rear corners of the vehicle. Use the loops as templates to mark, center punch and drill two 5/32" holes for each one. Install two #10 x 1/2" Oval Head Phillips Screws to secure each Footman Loop.

## 8 Install Horizontal Rod

Place the end of the Horizontal Rod against the outside of the Horizontal Rod Bracket on the windshield frame. Line up the hole in the rod with the hole in the bracket and install a 5/16" x 3/4" Hex Bolt with a Wing Nut to the inside of the vehicle.

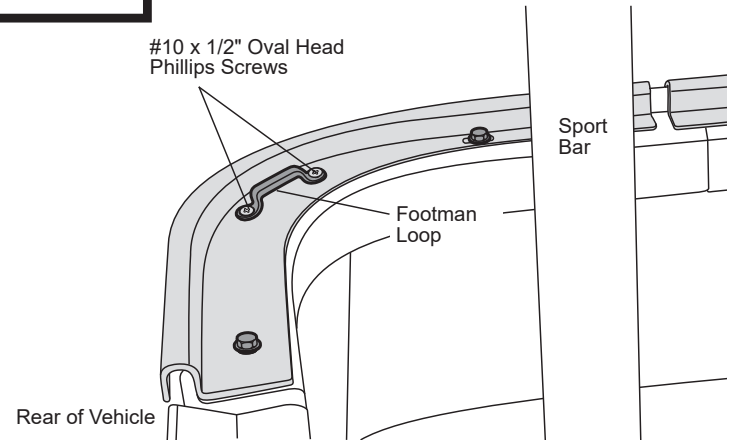
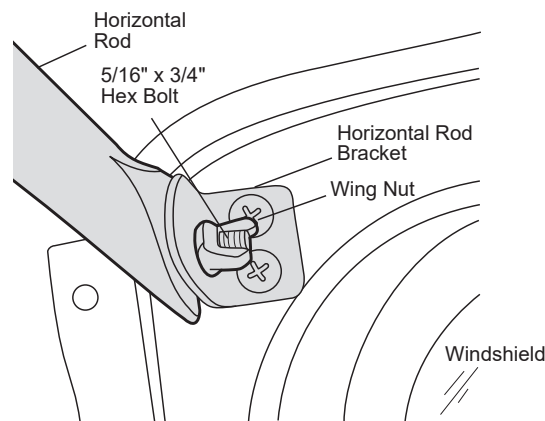



**CAUTION** Failure to make sure that the top fabric is centered, may result in damage to the top.

**10 Top into Windshield Retainer**

Orient the top on the vehicle. Start on one side and slide the front edge of the top into the channel in the Windshield Retainer. Make sure that the fabric is centered from side to side.

**NOTE** This step will be easier with two people.

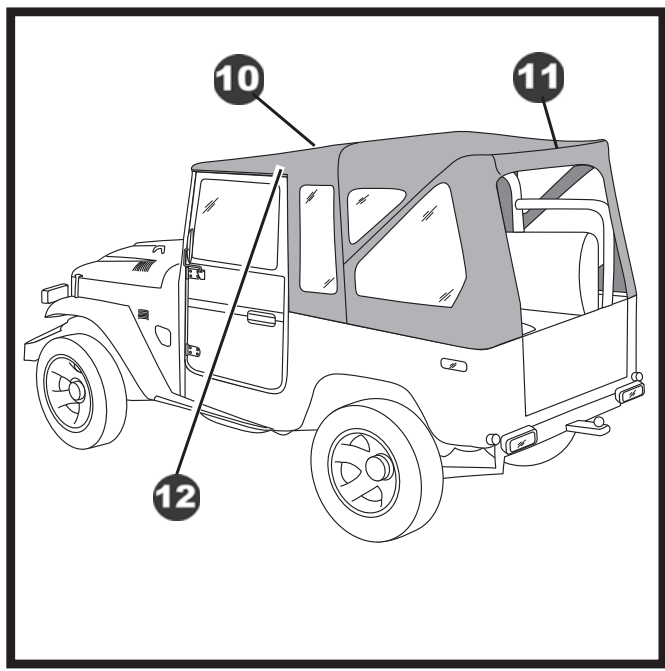
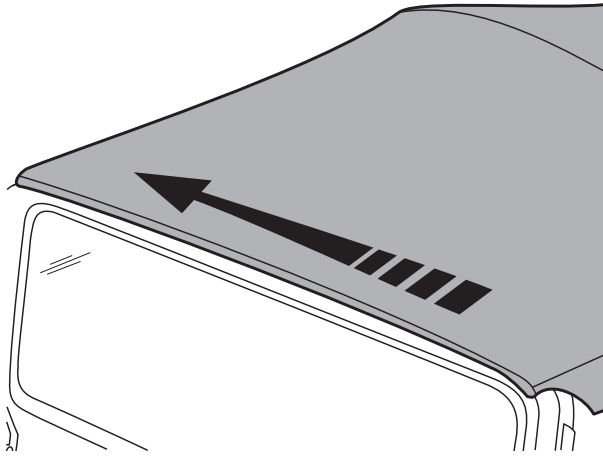

**12 Hook and Loop Flaps around Horizontal and Vertical Rods**

Locate the flaps along the top and rear of the door opening. Wrap the top flap around the Horizontal and fasten the Hook and Loop strips. Then wrap the other flap around the Vertical Rod and fasten the Hook and Loop.

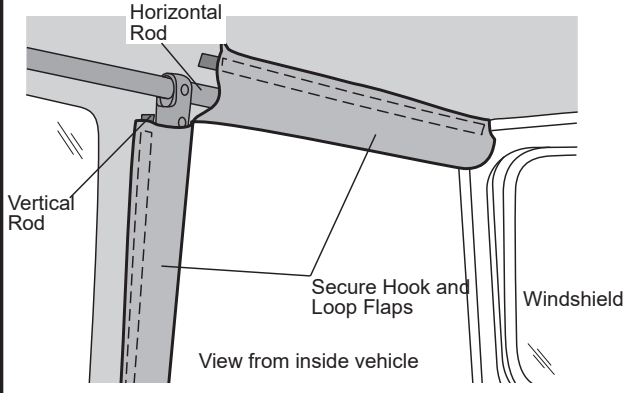

**11 Snap to Rear Bow**

Locate the six snap tabs sewn to the inside of the top above the rear window opening. Snap each of the tabs to the snaps on the rear bow.

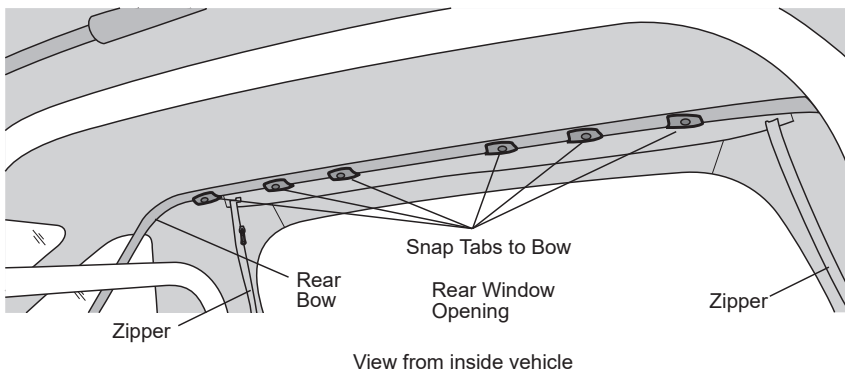

### 13 Install Plastic Retainers

Roll the plastic strips, sewn into the bottom of the top along the sides and rear corners into the Side Belt Retainers and the Rear Corner Retainers. It may be easier to start at the rear and work forward.

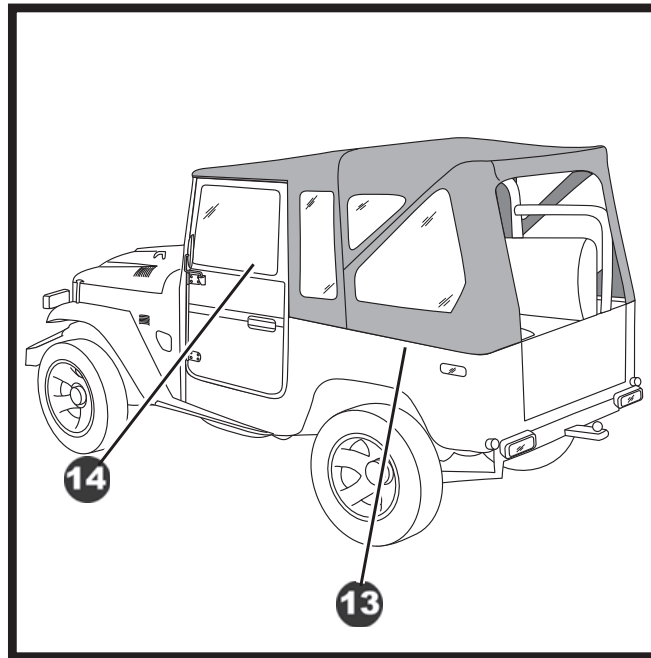
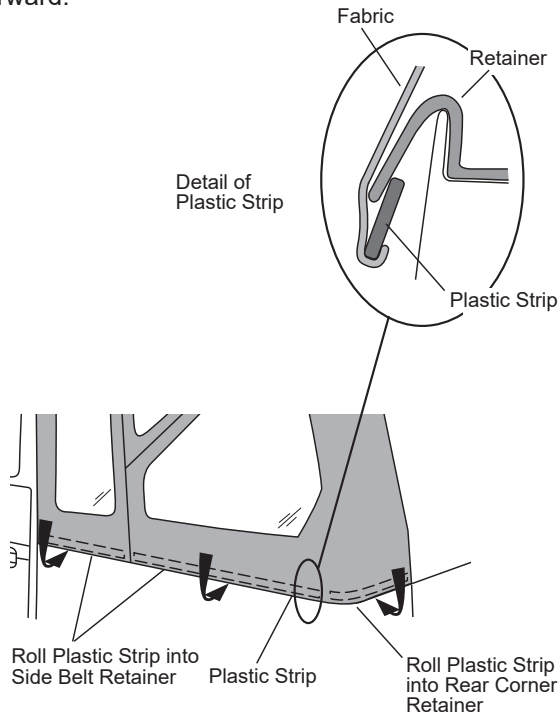

### 14 Slide Rear Bow into Position

Reach in through the zipper in the side panel and carefully slide the Rear Bow up on the Front Bow to increase the tension on the top. Insert the pin in the slide into the lowest of the three holes in the Front Bow.

**NOTE** The top will loosen up after a few hours in the sun. Then the pin may be inserted into a higher hole position.

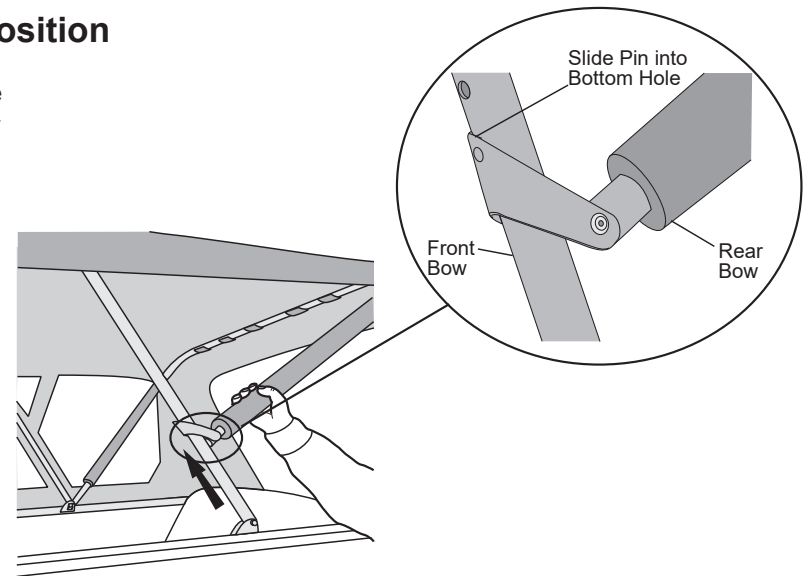

### 15 Thread Straps through Footman Loops.

Close the zippers in the side panels.

Locate the Buckle Straps in the parts kit. These straps will hold down the Rear Bow when the Rear Window is removed and the side panels are rolled up.

Wrap a strap around each corner of the Rear Bow and snap it to itself. Thread the Buckle Straps, on the Rear Bow, through the Footman Loops. Pull them up and thread them through the buckle.

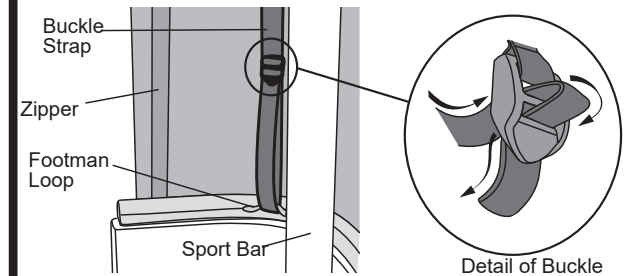



## 16 Install Rear Window

Open the tailgate and orient the Rear Window with the zippers toward the top and the vinyl side out. Zip the window to the Top. Close the zippers completely.

Locate the Adhesive Hook Strip in the parts kit. It attaches to the Loop Strip to provide a quick and secure fastener.

Pull the Rear Window down over the tailgate and use the Loop Strip to locate the area on the outside of the tailgate where the Adhesive Hook Strip will be installed. Clean the area on the tailgate with a 50/50 solution of alcohol and water. Make sure you remove all dirt, silicone sealants, wax and any other substances which might prevent the adhesive from sticking to the paint.

Do not remove the plastic backing until you are ready to install the hook strip. Pull the rear window down to the tailgate and mark the location of the loop on the outside of the tailgate. If necessary, cut the Adhesive Hook Strip to the desired length. Remove the plastic backing, align the strip with the marks and install the Adhesive Hook Strip on the tailgate. Use firm, direct pressure to insure maximum adhesion of the Hook Strip.

Wait one hour before completing the installation of your Supertop and avoid unnecessary fastening and unfastening of the Rear Window for 72 hours.

**NOTE** Do not attempt to install the Adhesive Hook in temperatures of less than 60° F. The adhesive backing will fully set within 72 hours of installation. You may install the Supertop after one hour, but you should avoid unnecessary fastening and unfastening of the Rear Window for 72 hours.

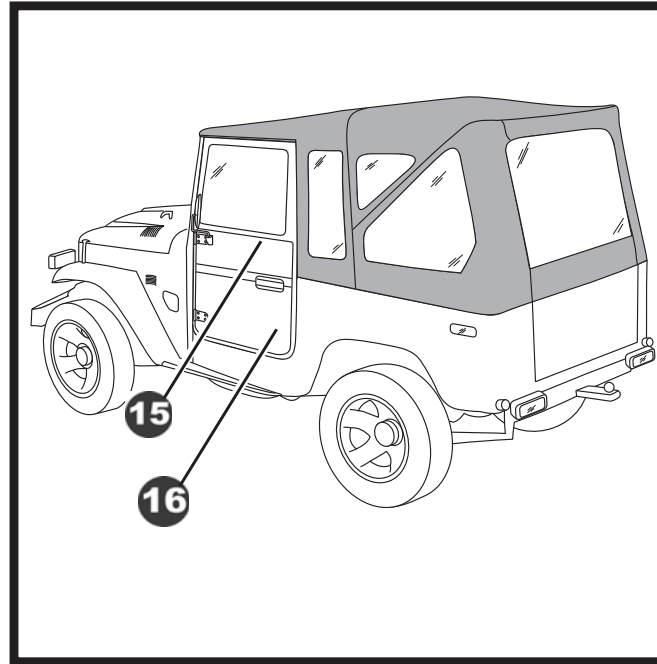

### CAUTION

Remove the Rear Window if the large side windows are rolled up.

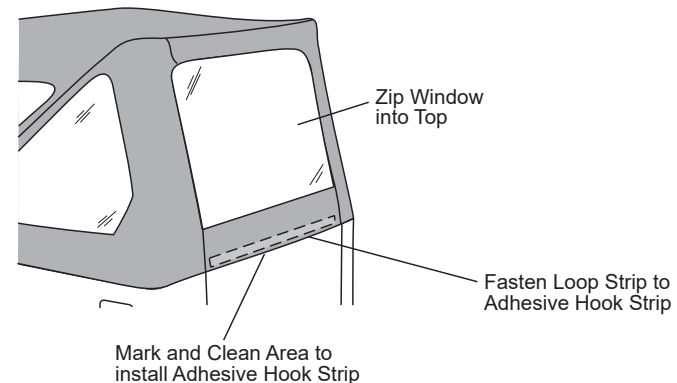



## Care and Maintenance of your Bestop Product

Your Bestop product is made of the finest materials available. To keep it looking new and for the maximum possible wear, it will need periodic cleaning and maintenance.

**Fabric:** The fabric should be washed often using soap, warm water and a soft bristle brush. Rinse with clear water to remove all traces of soap. Bestop recommends using Bestop Cleaner (part no. 11201-00) and Bestop Protectant (part no. 11202-00) for Vinyl fabric and Bestop Twill Protectant (part no. 11207-00) for Twill fabric. Bestop Cleaner and Bestop protectant are specially formulated to provide a total cleaning and protection system. Bestop Cleaner safely removes the toughest stains, will not harm vehicle finishes, is biodegradable and environmentally friendly. Bestop Protectant protects against UV-fading, cracking and hardening, and repels dust, grease, dirt and mildew.

**Windows:** Keep windows clean to avoid scratching. DO NOT use a brush on the windows! Wash with a water-soaked cloth or sponge and a mild dishwashing detergent. Bestop recommends Bestop Vinyl Window Cleaner (part no. 11203-00), which safely cleans and protects vinyl windows and helps prevent UV damage. NEVER WIPE THE WINDOWS WHEN THEY ARE DRY. Be careful when cleaning snow or frost from the vinyl windows since they are easily scratched and may crack at low temperatures. DO NOT roll the sides or rear window in cold weather. The windows become stiff and will crack. Cracks caused by misuse in cold temperatures are not covered under warranty.

**Water:** Seeping through at the seams may be stopped by applying 3-M Scotchgard® on the inside of the seams.

**Snaps:** Keep snaps cleaned and lubricated with silicone to help prevent snaps from sticking to the studs. If a snap does become stuck to a stud, use a screwdriver and GENTLY pry apart to prevent permanent damage to the snap or the top fabric.

**Zippers:** Keeping zippers cleaned and lubricated with Bestop's Zipper Cleaner (part no. 11206-00) will help prevent damage and keep the zippers in smooth working condition. If a zipper opens behind the slider, the slider may have been spread apart. This problem can usually be repaired by using an ordinary pair of pliers to bring the sides back into parallel. Return slider to the end of the zipper in the normal Open position. Squeeze lightly at first and test the zipper. If the zipper continues to remain open squeeze more firmly with the pliers and try the zipper again. Repeat this procedure until the zipper operates correctly.

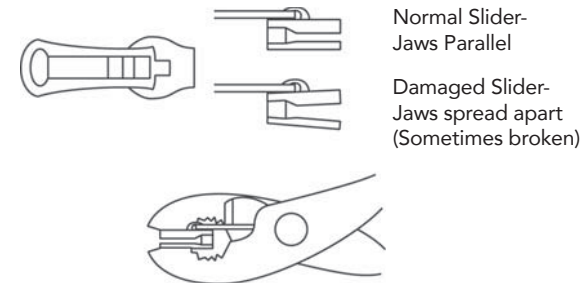

**For Bestop Warranty Information, Please go to;**  
<https://www.bestop.com/help/warranty-information/>

