



IMPORTANT! READ THIS FIRST!

Installation of shock absorbers or other suspension components requires special tools and expert knowledge. Accordingly, installation of all BILSTEIN products must be performed by a professional automotive suspension technician.

When replacing other brands, BILSTEIN shock absorbers or other suspension components should always be installed as a set. All BILSTEIN products must only be used for the specific, intended application as indicated in the application guide. **Any use of any BILSTEIN product other than for its intended use may result in serious bodily injury or death.**

Always use a chassis hoist for the installation of BILSTEIN products and make certain that the raised vehicle is securely attached to the hoist and/or supported to prevent the vehicle from slipping, falling, or moving during the installation process.

If you install any BILSTEIN product without the necessary special tools, expertise, and chassis hoist, you may subject yourself to the risk of serious bodily injury or death.

BILSTEIN shock absorbers are gas-filled and are highly pressurized.

- Never place any BILSTEIN shock absorbers in a vise or use a clamp on any BILSTEIN shock absorber.
- Never apply heat near any BILSTEIN shock absorber.
- Never attempt to open or repair any BILSTEIN product, in order to prevent **serious bodily injury or death.**

Any attempt to misuse, misapply, modify, or tamper with any BILSTEIN suspension product voids any warranty and **may result in serious bodily injury or death.**

While installing any BILSTEIN product:

- Do not use impact tools for loosening or tightening fasteners, because this may destroy the screw threads.
- Self-locking fasteners must only be used **once!**
- Reuse original equipment components only if they are in good condition, otherwise replace them with new components.
- Never remove the slight film of oil on the shock absorber piston rod and seal.
- All mounting fasteners for shock absorbers and other suspension components must be securely tightened before tension is placed on the suspension system, unless otherwise specified in the manufacturer's service manual or in this instruction.

After installing any BILSTEIN product:

- The suspension caster and camber must be checked and/or adjusted to comply with the vehicle manufacturer's specifications.
- The (load dependent) brake compensator and the anti-lock brake system must be checked and/or reset to comply with the vehicle manufacturer's specifications.
- The headlight aim must be checked and adjusted. Or, if applicable, adaptive headlights must be checked and recalibrated to comply with the vehicle manufacturer's specifications.
- If applicable, any/all Advanced Driver Assistance Systems (ADAS) must be checked and recalibrated to comply with the vehicle manufacturer's specifications.

CAUTION for COILOVER TYPE SUSPENSIONS!!!

If disassembling a coilover type suspension, refer to the vehicle manufacturer's service manual for proper procedures. The coil spring is preloaded and must be compressed with a spring compressor to release load before the upper mount is disassembled. Failure to follow the vehicle manufacturer's procedures may cause serious injury or death, and may damage the vehicle.

IMPORTANT!!!

This BILSTEIN product may or may not be compatible with non-BILSTEIN aftermarket products and/or vehicle modifications. It is the responsibility of the professional automotive suspension technician performing the installation to identify any non-OEM components and/or modifications on the vehicle that may interact with the suspension system. These must be evaluated for any potential physical static or dynamic interference with and/or effect on the function of this BILSTEIN product.

E-WM05-0000159AA MOUNTING INSTRUCTION



This instruction is for both left front (driver) 41-326343 and right front (passenger) 41-326350 B8 8112 shocks. A step by step process is shown with pictures of the right front. The left front is a mirror image. Skip to the end to see final result for both sides. A bill of materials (BOM) of the included mounting part kits is shown on the next three pages.

It is normal to hear a slight audible clicking noise during compression and rebound strokes in the B8 8112 shocks, most notably during low velocity events. This is due to the internal pistons engaging each other creating the position sensitive compression and rebound zones.

Bill of Materials- LEFT FRONT

Item #	Description	Qty
1	Support Plate	1
2	Flat Head Screw; M8x1.25; L=18	2
3	Serrated Flange Nut; M8x1.25	2
4	Flange Head Cap Screw, M8x1.25, L=30mm	2
5	Reservoir Clamp	1
6	Socket Head Cap Screw, M6x1, L=50mm	1
7	Nylock M6x1	1
8	Circlip	1
9	ABS Line Relocation Bracket, Left Front	1
10	Zip Tie	2
11	Flange Locknut; M10x1.5	3
12	Reservoir Bracket Spacer	1

E-WM05-0000159AA MOUNTING INSTRUCTION

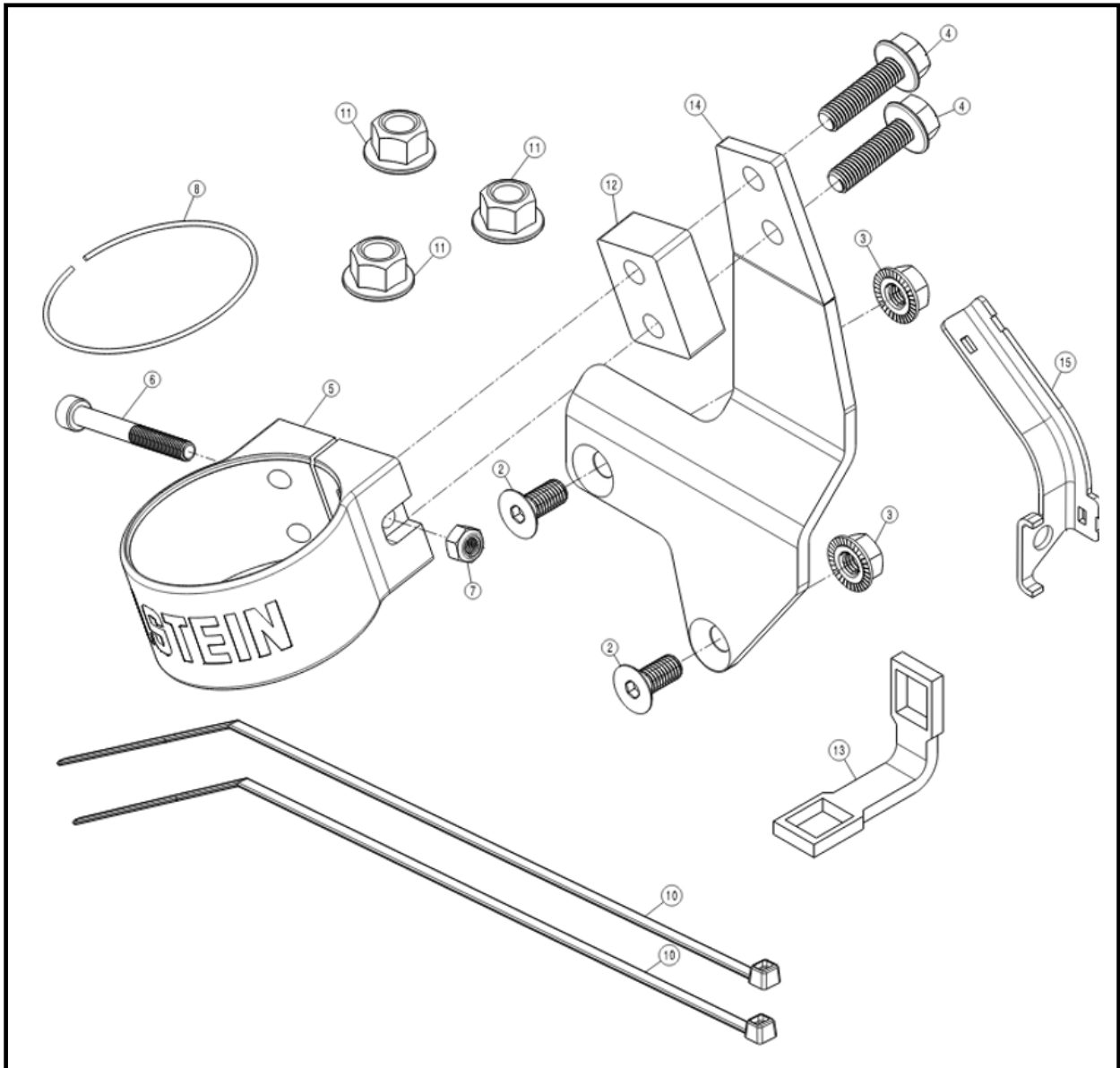

Bill of Materials- RIGHT FRONT		
Item #	Description	Qty
14	Support Plate	1
2	Flat Head Screw; M8x1.25; L=18	2
3	Serrated Flange Nut; M8x1.25	2
4	Flange Head Cap Screw, M8x1.25, L=30mm	2
5	Reservoir Clamp	1
6	Socket Head Cap Screw, M6x1, L=50mm	1
7	Nylock M6x1	1
8	Circlip	1
15	ABS Line Relocation Bracket, Right Front	1
10	Zip Tie	2
11	Flange Locknut; M10x1.5	3
12	Reservoir Bracket Spacer	1
13	Installation Tool	1

E-WM05-0000159AA MOUNTING INSTRUCTION



Bill of Materials- LEFT FRONT		
Item #	Description	Qty
16	Sway Bar Spacer; Left	1
17	Flat Head Screw; M10x1.25; L=30	4
18	Flange Nut; M10x1.25	2
19	Spacer	2

Bill of Materials- RIGHT FRONT		
Item #	Description	Qty
20	Sway Bar Spacer; Right	1
17	Flat Head Screw; M10x1.25; L=30	4
18	Flange Nut; M10x1.25	2
19	Spacer	2

IMPORTANT!!! This BILSTEIN product is NOT compatible with OE wheel backspacing. Wheels with a maximum of 4.5" backspacing must be used (equates to a 8.5" width wheel with a -6 offset). The largest tire size that will clear the remote reservoir with a 4.5" backspaced wheel is a 285 width. Final installation must be evaluated for any potential physical static or dynamic interference between the reservoir and the wheel/tire.

B8 8112 Shock Installation Procedure:

Note: the shocks depicted herein differ in appearance from the supplied components.

- A. Disconnect the bolts holding the front skid plate to the vehicle (2 per side) with a 12mm socket and remove skid plate.
- B. Disconnect the sway bar bolts holding sway bar to frame (2 per side) with a 14mm socket and drop the sway bar as shown in the pictures below. Disconnect sway bar end links and remove sway bar from vehicle. Follow all procedures in the vehicle manufacturer's service manual.



E-WM05-0000159AA

MOUNTING INSTRUCTION



- C. Remove existing shock module from the vehicle following all procedures in the vehicle manufacturer's service manual. Save the lower shock bolt and nut as they will be used later.
- D. Before installing the B8 8112 shocks on the vehicle check if they are set at the desired lift height. The pre-set lift height is as follows:

2.4" for 4Runner 4WD V6 & FJ Cruiser 4WD models.

All other models require an adjustment to the spring seat position(s) prior to installation.

- E. If the above-mentioned pre-set lift height is not what is desired, or you have a model that is not a 4Runner 4WD V6 or FJ Cruiser 4WD, proceed to step F. Otherwise, skip to step M.
- F. Break the spring seat lock ring loose with the supplied spanner wrenches. Refer to Figure 1 below.
- G. Note the clocking of the lower mount relative to the studs on the upper mount (important for reassembly).
- H. Using an appropriate spring compressor, compress the spring until it can be rotated freely by hand. Then, spin the spring seat up or down depending on what the desired lift height is. Note that on 4x4 V6 models the right side (passenger) spring seat should always be approximately 3/8" lower than the left side (driver) to compensate for the inherent vehicle lean. On all other models the spring seats should be the same for the right and left sides. See the lift height tables below and on the next page for clarification and for a few points of reference between the amount of exposed thread and estimated lift height. They are listed for stock weight vehicles.

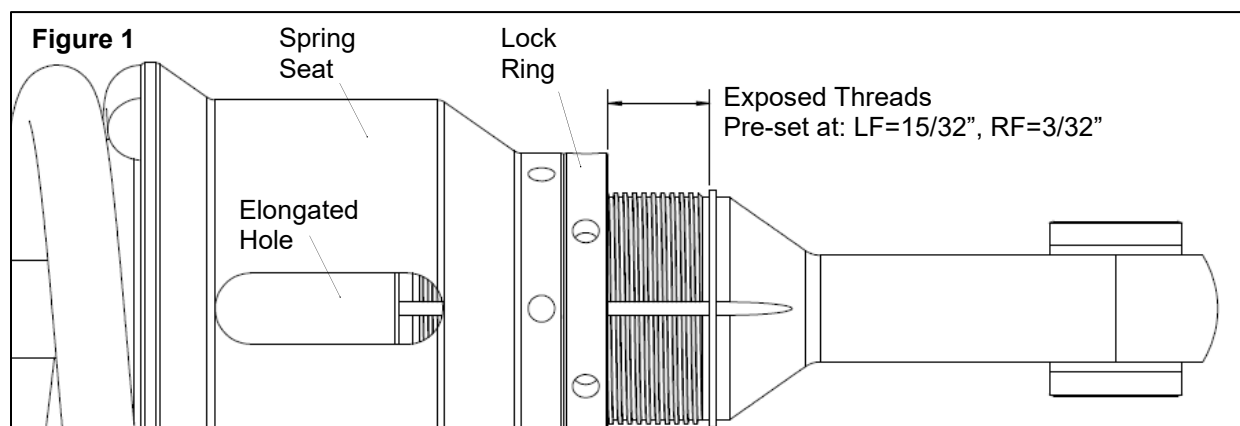

DO NOT EXCEED MAX LIFT HEIGHT LISTED FOR YOUR VEHICLE

'03-'09 4Runner 4WD V6 & '07-'09 FJ Cruiser 4WD		
Exposed Threads		B8 8112 Typical Lift Heights**
Left Front	Right Front	
1"	19/32"	3.3" Lift
11/16"	5/16"	2.8" Lift
13/32"	0" (very bottom)	2.2" Lift

'03-'09 4Runner 2WD V6	
Exposed Threads	B8 8112 Typical Lift Heights**
Left & Right Front	
11/16"	4" Lift
5/16"	3.3" Lift
0" (very bottom)	2.8" Lift

E-WM05-0000159AA MOUNTING INSTRUCTION



'03-'09 4Runner 4WD V8	
Exposed Threads	B8 8112 Typical Lift Heights**
Left & Right Front	
13/16"	3.4" Lift
13/32"	2.3" Lift
0" (very bottom)	1.3" Lift

'03-'09 GX 470	
Exposed Threads	B8 8112 Typical Lift Heights**
Left & Right Front	
1 3/16"	3" Lift
13/16"	2.4" Lift
13/32"	1.8" Lift
0" (very bottom)	1.3" Lift

** Lift heights indicated are typical. Actual lift height is influenced by which factory suspension the vehicle is equipped with and its condition; optional equipment and accessories on your vehicle, and other vehicle modifications such as replacement coil springs, wheel and tire combinations, etc.

Modifying/lifting the suspension to your vehicle may raise its center of gravity and may make it more susceptible to loss of control and/or rollover, which may result in death or serious injury. We strongly recommend that you offset the loss of rollover resistance as much as possible by increasing tire track width. Wear seat belts and shoulder harnesses at all times, and avoid situations where a side rollover may occur.

NOTE: if you exceed the recommended spring seat adjustment range (exposed thread dimension) for your vehicle, make sure to measure the shock at ride height as shown below after the install. This is needed to ensure there is at least 2" of droop travel from static ride height and so the stiffer rebound zone is not being engaged at ride height.

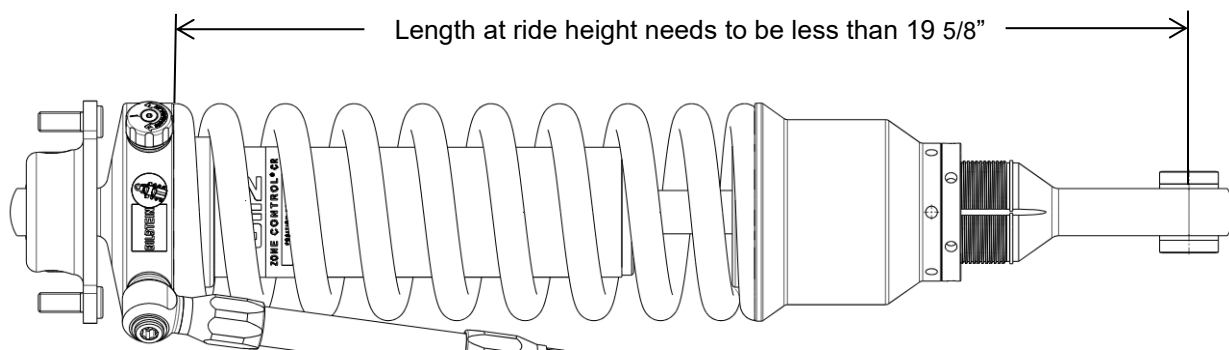

Left Front (driver) depicted

- I. Before finalizing the desired lift height, position the elongated hole (see Figure 1) in the spring seat so it will face inboard once installed on the vehicle.
- J. Once the desired lift height is set, tighten lock ring against spring seat using supplied spanner wrenches.

Torque lock ring to spring seat 37 ft-lb (50 Nm).

- K. Rotate the lower shock mount so it is aligned with the upper mount studs as noted in step H.
- L. Slowly release the spring compressor.

E-WM05-0000159AA MOUNTING INSTRUCTION



M. Remove the splash guard clip and rectangular frame hole plug circled in red below. Tuck back splash guard.

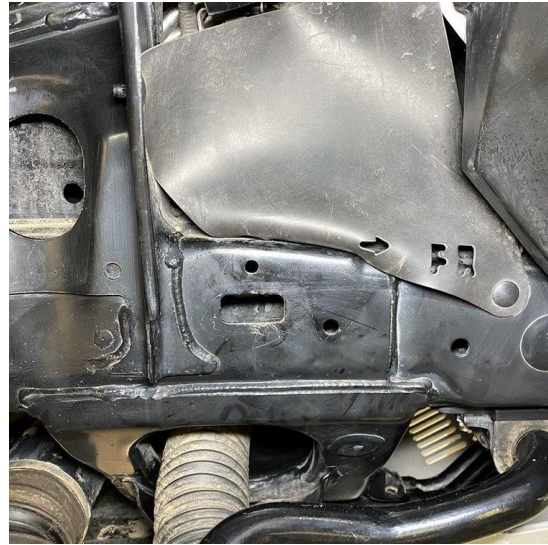

N. Slide the Reservoir Clamp (BOM item #5) over the reservoir as shown below.



E-WM05-0000159AA MOUNTING INSTRUCTION



- O. Place the Nylock (BOM item #7) in the slot in the Reservoir Clamp as shown below. Then place the Socket Head Cap Screw (BOM item #6) through the hole in the Reservoir Clamp, threading it into the Nylock. Thread in a few turns for now with a 5mm hex but leave loose enough so the Reservoir Clamp can be slid up and down. Install the Circlip (BOM item #8) on the external groove located at the center of the Reservoir.

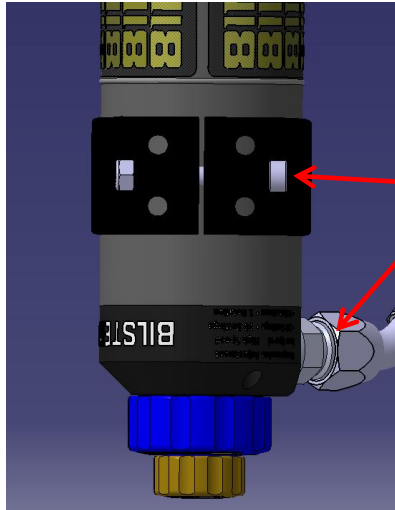

Install SHCS on the same side as the hose exit (this is only critical for right side)

- P. Prepare the following assembly by applying non-permanent thread locker to the two Flange Head Cap Screws (BOM item #4). Using the Reservoir Bracket Spacer (BOM item #12), mount the Reservoir Clamp to the Reservoir Support Plate (BOM item #14) as shown below using the two Flange Head Cap Screws. Tighten using a 13mm socket.

Torque Flange Head Cap Screws to 18 ft-lb (25 Nm).

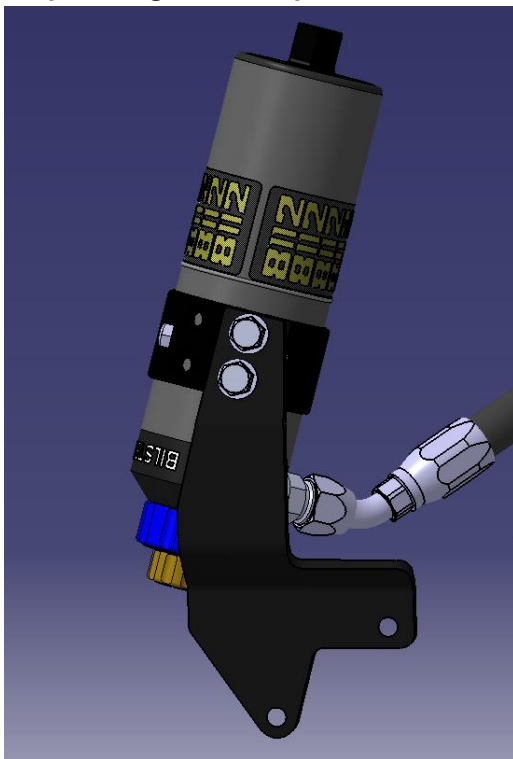

back side view



front side view

E-WM05-0000159AA MOUNTING INSTRUCTION

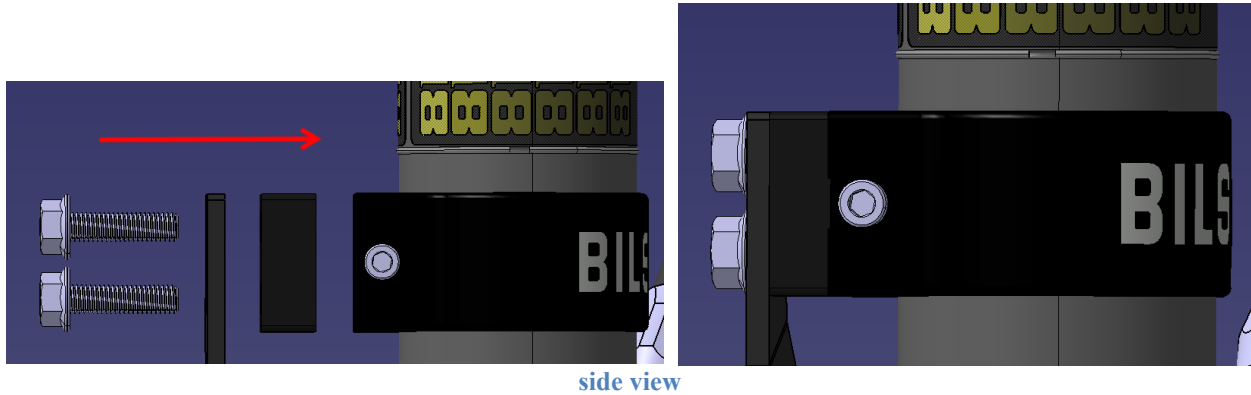

- Q. Install the shock onto the vehicle as shown below. Use the three Flange Locknuts (BOM item #11) and a 15mm socket to attach the upper mount. Leave reservoir hanging temporarily.
Torque Flange Locknuts to 33 ft-lb (45 Nm).
- R. Attach the lower shock mount with the OE shock bolt and nut that was removed in step C.
Torque lower OE shock bolt and nut to service manual specification.



Note: picture is of 2010+ 4Runner

E-WM05-0000159AA MOUNTING INSTRUCTION



- S. Mount the reservoir assembly to the frame with the two holes shown below. Apply non-permanent thread locker to two Flat Head Screws (BOM item #2). Have another set of hands hold the reservoir assembly in place. Hold the Serrated Flange Nuts (BOM item #3) on the inside of the frame through the rectangular hole with the Installation Tool (BOM item #13). Then, thread the two Flat Head Screws through the holes in the Reservoir Mount Plate and frame, and into the Serrated Flange Nuts. Tighten down the Flat Head Screws with a 5mm hex. Once they are snug, the Installation Tool can be removed. The serrations will hold the nuts in place while the screws are tightened. **Torque Flat Head Screws to 16 ft-lb (22 Nm).**

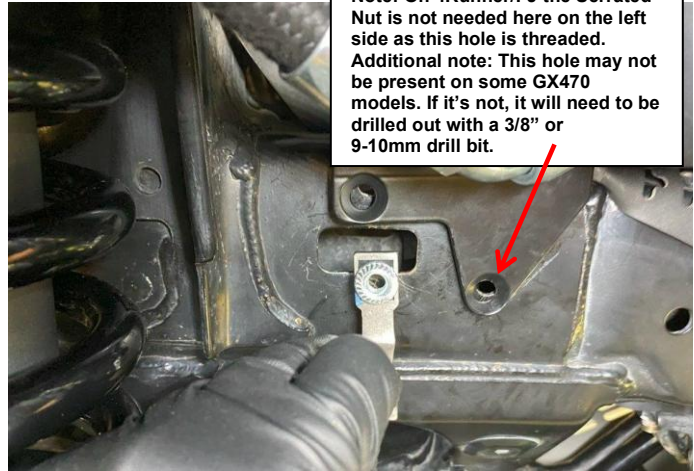



- T. Re-install the rectangular frame hole plug that was removed in step N.
- U. Re-attach and torque outer tie rod (if removed) and control arm to knuckle ball joint nut according to service manual specifications.
- V. Slide the reservoir down in the clamp so the Circlip is resting on the top side of the clamp. Position the reservoir as shown above and confirm it is not contacting anything on the vehicle. Confirm the reservoir hose is not contacting the upper control arm (at full droop). If it is, create some clearance by rotating the reservoir so it pulls the hose fitting in-board. Tighten the Socket Head Cap Screw (BOM item #6) that was installed in step P.
Torque the Socket Head Cap Screw to 6 ft-lb (8 Nm).

Sway Bar Relocation Installation

- W. Prepare the following assembly by applying non-permanent thread locker to four Flat Head Screws (BOM item #17). Place two of them into the countersunk holes in the Sway Bar Spacer (BOM item #20) as shown below.

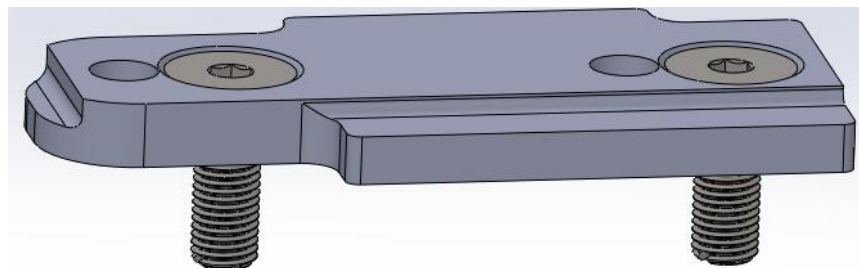

E-WM05-0000159AA MOUNTING INSTRUCTION



- X. Place the other two Flat Head Screws up through the countersunk holes on the bottom side of the Sway Bar Spacer. Mount the Sway Bar Spacer assembly to the frame using the existing threaded holes that the OE sway bar bracket was removed from in step B. Tighten using a 6mm hex.
Torque Flat Head Screws into frame to 32.5 ft-lb (44 Nm).

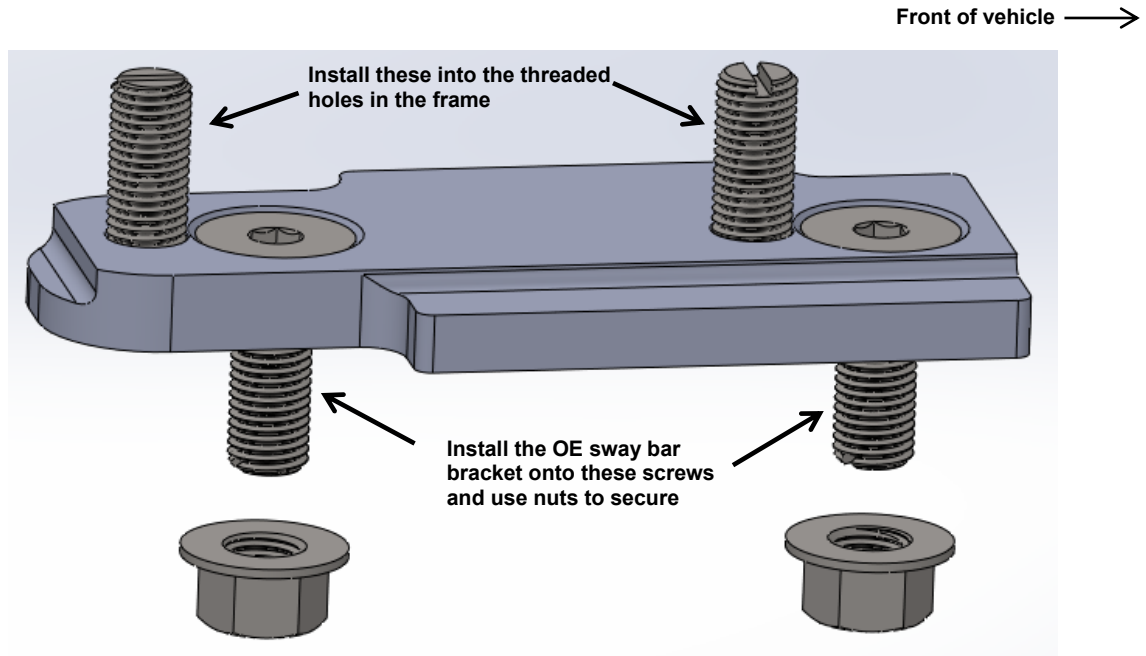

- Y. Install the OE sway bar bracket as shown above and secure with the two Flange Nuts (BOM item #18 using a 15mm wrench. Place a flat head screw driver into the slot in the end of the Flat Head Screw to keep it from rotating while tightening the Flange Nut.
Torque Flange Nuts to 32.5 ft-lb (44 Nm).

- Z. Re-install the skid plate with the bolts that were removed in step A (2 per side). Skid plate spacers (BOM item #18) are included if the skid plate needs to be spaced down to prevent contact with the sway bar (2 per side). Only vehicles with bent skid plates will require the spacers.
Torque skid plate bolts to service manual specification.

ABS Line Relocation Bracket Installation

- AA. Clip and remove the OE zip tie shown in the image below (circle #1) and remove ABS line from bracket (circle #2). Be careful to not damage the ABS line during this process.



- BB. Remove OE ABS line bracket by removing the hex head cap screw with a 10mm socket.
- CC. Install the ABS Line Relocation Bracket (BOM item #15) as shown below with the same hex head cap screw that was removed in the previous step. Secure ABS line with two zip ties (BOM item #10) as shown below. Trim excess zip tie length after installation.



front view



back view

- DD. Check wheel alignment and adjust to the vehicle manufacturer's specifications. This completes the installation.

E-WM05-0000159AA
MOUNTING INSTRUCTION



Final left front (driver) 41-326343 B8 8112 shock installed on vehicle:



E-WM05-0000159AA
MOUNTING INSTRUCTION



Final right front (passenger) 41-326350 B8 8112 shock installed on vehicle:





Dual Speed Reservoir Adjustment

These dampers come equipped with independent high and low speed compression damping adjusters located on the reservoir. The high speed is the blue knob and is labeled as such, and the low speed is the gold knob and is labeled as such. The **FULL FIRM** setting for each adjuster knob is achieved when the knob is turned all the way **CLOCKWISE**. The **FULL SOFT** setting for each adjuster knob is achieved when the knob is turned all the way **COUNTER-CLOCKWISE**. To make high or low speed adjustments, simply turn each knob individually until the desired level of control is achieved. To stiffen the ride, turn the knobs clockwise. To soften the ride, turn the knobs counter-clockwise.

The factory setting of these adjusters are as follows:

- High Speed (blue knob) – 6 clicks counter-clockwise from fully firm.
(10 total settings are available which translates to 9 clicks; 1 rotation)
- Low Speed (gold knob) – 13 clicks counter-clockwise from fully firm.
(20 total settings are available which translates to 19 clicks; 2 rotations)

Please note: It's normal for the high speed (blue) knob to become significantly more difficult to turn when progressing to the firmer end of the adjustment range; particularly during the last 3 to 4 settings/clicks. This increased difficulty is a result of the increasing preload of the high speed valve stack shims. To aid in ease of adjustment at the firmest end of the high speed range, it's optional to use Bilstein wrench part # E-XS01-0000004. This is included in most kits and if not, available separately. Additionally, it's normal for the clicks on the high speed (blue) knob to become less pronounced at the firmer end of the adjustment range.



Dual Speed Reservoir Adjuster

Zone Control JCO (Jounce Cut-off) Adjustment

These dampers also come equipped with an adjuster for the JCO (jounce cut-off) system. This blue adjuster knob is located on the mount cap above the coil spring. The **FULL FIRM** setting for the adjuster knob is achieved when the knob is turned all the way **CLOCKWISE**. The **FULL SOFT** setting for the adjuster knob is achieved when the knob is turned all the way **COUNTER-CLOCKWISE**. To make JCO adjustments, simply turn the adjuster knob clockwise for more bottom out control and counter-clockwise for less bottom out control. The adjustment will not affect the ride quality when the vehicle is in the main damping zone at regular ride height.

The JCO adjuster factory setting is:

- 6 clicks counter-clockwise from fully firm.
(10 total settings are available which translates to 9 clicks; 1 rotation)



JCO (Jounce Cut-off) Adjuster

B8 8112 service:

For service of your B8 8112 shocks, please contact:

THYSSENKRUPP BILSTEIN OF AMERICA
Toll Free: 1-800-537-1085
bilsteinus.com